

ARTICLE

Fuzzy Logic Based Perceptual Image Hashing Algorithm in Malaysian Banknotes Detection System for the Visually Impaired

Wai Kit Wong* Chi Jie Tan Thu Soe Min Eng Kiong Wong

Faculty of Engineering and Technology, Multimedia University (MMU), Jalan Ayer Keroh Lama, Melaka, 75450, Malaysia

ARTICLE INFO

Article history

Received: 17 May 2021

Accepted: 20 May 2021

Published Online: 1 June 2021

Keywords:

Fuzzy logic

Image processing

Banknote reader

Malaysian banknote

Visually impaired

ABSTRACT

Visually impaired persons have difficulty in business that dealing with banknote. This paper proposed a Malaysian banknotes detection system using image processing technology and fuzzy logic algorithm for the visually impaired. The Malaysian banknote reader will first capture the inserted banknote image, sending it to the cloud server for image processing via Wi-Fi medium. The cloud server is established to receive the banknote image sending from the banknote reader, processing them using perceptual hashing based image searching and fuzzy logic algorithm, then return the detected banknote's value results back to the banknote reader. The banknote reader will display the results in terms of voice message played on the mini speaker attached on it, to allow visually impaired persons knowing the banknote's value. This hardware mechanism reduces the size and costs for the banknote reader carried by the visually impaired persons. Experimental results showed that this Malaysian banknotes detection system reached an accuracy beyond 95% by running test on 600 different worn, torn and new Malaysian banknotes. After the banknote image being taken by the banknote reader's camera, the system able to detect the banknote value in about 480 milli-seconds to 560 milli-seconds for a single sided banknote recognition. The banknotes detection speed was also comparable with human observers reading banknotes, with the response of 1.0908 second per banknote slight difference reading time. The IoT and image processing concepts were successfully blended and it provides an alternative to aid the visually impaired person their daily business transaction activities in a better way.

1. Introduction

Today, based on the influence of technology breakthrough, human lifestyle has getting more cosy due to the advancement in electronics devices like smartphones, Virtual Reality and etc. However, there are still very little attentions given to the disabled group, especially the visually impaired person. The estimated world

population of visually impaired person is 285 million, among them 246 million are having low vision and 39 million of them are totally blind. Majority of the visually impaired person are elderly people in which 82% of them are fully blinded and 65% of the visually impaired person are aged 50 years old and above ^[1]. In Malaysia, The National Eye Survey ^[2] that was executed in 1996 collected statistics that the generality of blindness and

*Corresponding Author:

Wai Kit Wong,

Faculty of Engineering and Technology, Multimedia University (MMU), Jalan Ayer Keroh Lama, Melaka, 75450, Malaysia;

Email: wk Wong@mmu.edu.my

low vision Malaysian citizens are about 0.29% and 2.44% of the total citizens respectively.

Visually impaired persons are facing difficulties with many usual daily activities such as driving, reading, socializing and running businesses. They have no ability to read banknotes and performing business transaction. For this purpose, a Malaysia Banknotes Detection System is developed to aid the visually impaired person reading Malaysian banknotes value. Some banknote detection techniques for visually impaired person are proposed worldwide like classification by length of banknote^[3], classification by Braille Text/Tactile Mark^[4], classification by folding of banknote^{[5], [6]} and modern gadgets to analyses the value of banknotes through the application of machine vision^[7] and Artificial Intelligence^[8].

Classification by length of banknote is used in countries such as India, Australia, Malaysia (Old banknote) and etc. This banknote detection technique is using a card identifier to identify different banknotes based on the length. This banknote detection technique is easy to use and the banknote detection tool used is small in size. However, it is not suitable to use for detecting current version of Malaysian banknotes because the size of current Malaysia Banknotes version is not individually different from one another.

Canada produces their banknote in such a way that there is Braille text on top corner of the banknote where blind people can easily feel it and understand the value. A similar braille text method is also used in countries like Brazil, Mexico and Australia where tactile mark or special raised symbol are printed on banknotes which indicate the value of the banknote. Classification by Braille Text/Tactile Mark is simple to use for the visually impaired who learned Braille text. However, this kind of banknote detection method is harder for machine to detect instead of human reading. It is not suitable to use for Malaysian banknotes detection because Malaysian banknotes do not have Braille text printed on it.

Classification by folding of banknote is the oldest technique used by visually impaired persons to detect banknotes value. Visual impairment person is taught since their young age on how to identify value of the banknote based on the way it is folded. This is the most popular way among the blind because of its simplicity, since everyone can easily fold the money if the rules are known beforehand or taught. However, it is not suitable to use for Malaysian banknotes detection because it will cause damage to the latest series of Malaysia Banknote, which are made from polymer material.

Modern gadgets to analyse the value of banknotes through the application of machine vision and Artificial

Intelligence is a new trend. This approach might not be very convenient to use by visually impaired person since the gadgets required power charging and most of them are touchscreen based. However, this approach is very efficient and more precise in banknotes detection. This approach is identified to be suitable for Malaysian banknotes detection because the image detection technique is very powerful in analysing the value of the banknote. Image processing technique had been widely used in pattern recognition, colour processing, image sharpening, machine/robot vision, medical imaging and etc. By adopting this technique in Malaysian banknotes detection, it can aid the visually impaired person to “view” the banknotes using camera lens and distinguish those banknotes through a developed image processing algorithm.

The proposed Malaysian banknotes reader in this paper is a wireless portable reader that is user friendly to the visually impaired person. The emerging of Wi-Fi Technology^[9] provides a room for this product development to minimize the device size by getting rid of carrying the bulky processor along head and replace with a cloud server. This meeting the Internet of Thing (IoT) concept that the hardware developed for the banknote reader will be able to capture the image of the user inserted banknote into a dedicated slot built on it, and send it to the cloud server for image processing via the on-board Wi-Fi communication tool.

Perceptual image hashing algorithm finds increasing attention in several multimedia information processing applications, especially in image security and authentication^[10,11]. The working principle for a Perceptual Image Hashing function is mapping an input image to a fixed size binary string named as “image hash”, based on an image’s appearance to human eyes^[12]. These hash values are used to represent the digital image contents. That will tolerate content preserving distortions but will also reject malicious attacks that alter the image contents. Hence, the images with the same visual appearance may have identical hash values, whereas those visually distinct images should have totally dissimilar hash values. Fuzzy logic is a reasoning method that employed fuzzy rules set^[13] to handle the vagueness decision of a detected banknote.

In this paper, Fuzzy Logic based Perceptual Image Hashing Algorithm in Malaysian Banknotes Detection System is developed for the Visually Impaired person. The developed Malaysian Banknotes Detection System consisted of a handheld Malaysian Banknotes Reader and a server. Perceptual image hashing algorithm and fuzzy logic are adopted in the final banknote value decision mak-

ing. The rationale of choosing perceptual image hashing based algorithm rather than the common standard feature extraction method is because perceptual image hashing algorithm may enable the universal banknote detection whereby in the future, the system can extend to detect other countries' banknotes, and this can be implemented simply by expanding the current database. Furthermore, the strength of perceptual image hashing is that "the hash functions are comparable if the images are similar". Input image and database image are matched in term of their perceptual content. This is quite simple and straightforward.

The paper is organized in the following way: Section II will be briefly comments on the Malaysian Banknotes Reader System. Section III presents the proposed Fuzzy Logic Based Perceptual Image Hashing Algorithm applies in identifying the correct Malaysian banknotes values and section IV reports some experimental results. Finally, in section V, some conclusions and envision on future developments are drawn.

2. Malaysian Banknotes Detection System Design

The Malaysian Banknotes detection system design is outlined in this section. It comprises the hardware architecture and software modules of the Malaysian Banknotes reader system as addressed in section 2a and section 2b below.

(a) Hardware Architecture

Figure 1 shows the hardware architecture for the proposed Malaysian Banknotes Reader System. The overall system comprises of an integrated imaging tool/Wi-Fi module, battery, microcontroller, speaker module and the server. The system is initiating by the visually impaired person pressing the start button on the handheld banknote reader. The image of the inserted banknote will be captured and sent to the server through Wi-Fi module. The captured banknote image will be processed and analysed by the server using the image processing

algorithm discussed in Section 3. Classification of the banknotes result is done by adopting Fuzzy logic reasoning before the decision is returning to the banknote reader for reporting. In the microcontroller of the banknote reader, the received result that indicates the value of the banknote will be outputted as a voice message played on the speaker. The functioning flowchart of the hardware architecture can be clearly realized with the flowchart as depicted in Figure 2. Each of the components stated in Figure 1 will be discussed in details in the following sub-section.

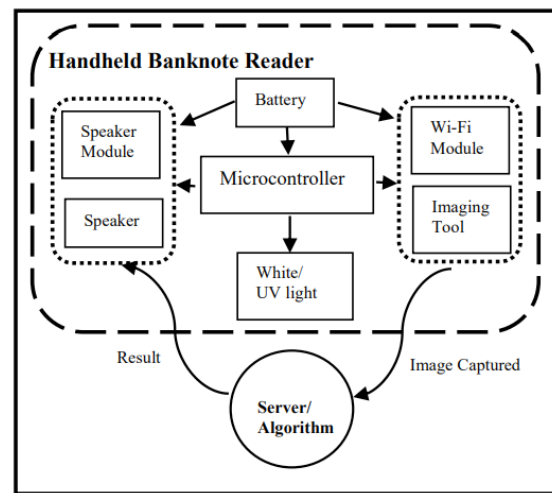

Figure 1. Malaysian Banknotes Reader Hardware Architecture

(i) Imaging Tool and Wi-Fi-Module

The main consideration of the imaging tool selection is the tool can obtain a clear image of the whole banknote. A good quality imaging tool can secure a higher success rate in detecting the banknote denomination. Other than imaging quality, cost of the imaging tool is also a consideration. Hence, a CMOS camera is adopted instead of a CCD camera due to the cheaper price and CMOS camera has the latest pixel architecture which has higher sensitivity. This selection is important since some imaging task may sometimes run in a dark/low light environment.

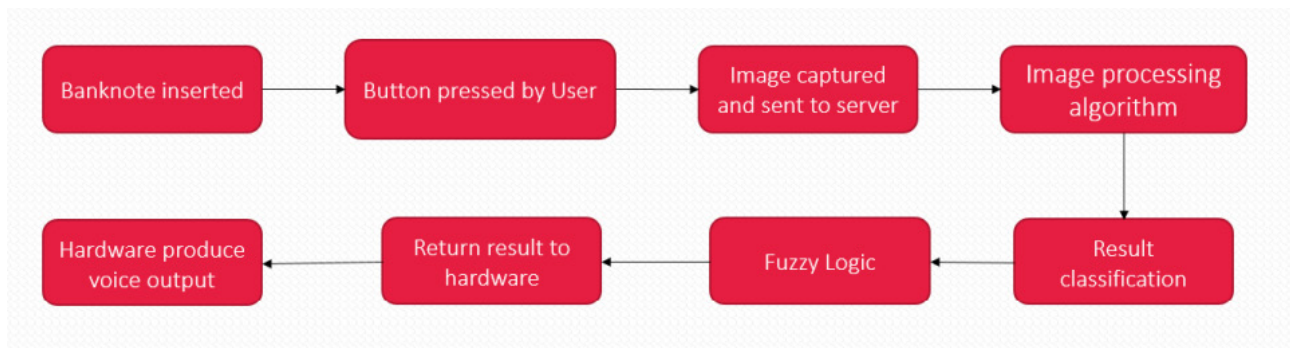

Figure 2. Malaysian Banknote Reader Functioning Flowchart

CMOS camera also has better pixel depth and saturation compared to CCD camera.

The chosen CMOS camera should have a small focal length, in order to get short focal distance between the camera and the captures banknote in the final product (Ideal focal distance is less than 3 centimetres). Such choice may ease the visually impaired person to carry a convenient size banknote reader with them from time to time. A few CMOS cameras were studied. The first highlighted imaging tool is the CMOS VGA Camera (ARM cortex pairing with M7 Micro-Controller). This camera module has the advantage of capturing high resolution image. However, the focal length of this camera is too long (minimum 5 centimeters) and hence give rise to long focal distance, which is not suitable for the banknote reader's design consideration. Other than that, this camera module price is also quite high (around RM250 per set).

ESP-32 CAM module was selected as the second option. ESP-32 is a microcontroller set combine with Wi-Fi and Bluetooth communication module, whereby ESP-32 CAM module is the integration of ESP-32 with a XRZ-00D1 camera. This imaging tool module is quite fit for banknote reader since it is not only consisting of a camera. The Wi-Fi communication module embedment is also useful for images and command instructions transferring. The price of ESP-32 CAM module is cheap (around RM25 per set). However, after bought and tested the ESP-32 CAM, the XRZ-00D1 camera did have a shorter focal length, but the focal length is not short enough (greater than 3 centimetres) to capture the image of banknote within acceptable range. The sample of the ESP-32 CAM tested result is shown in Figure 3a.

Since ESP-32 series with Wi-Fi and Bluetooth communication module is very much fit to the banknote reader objective, similar camera modules from this ESP-32 series are further surveyed. The third option is ESP-32 EYE module which having the same occupied XRZ-00D1 camera but embedded with a better image recognition program. However, it is also rejected due to the same reason of greater than 3 centimetres focal length (similar to ESP-32 CAM).

The final option is an ESP-32 based development board developed by LILYGO, named as TTGO T-journal module. This T-Journal module uses the ESP-32 as its microcontroller which has the Wi-Fi communication feature and the adopted imaging tool is an OV2670 CMOS Camera. OV2670 CMOS Camera has similar focal length with XRZ-00D1 camera. However, the OV2670 camera paired with an alternative fish eye lens that is able to increase the field of view and hence decrease the focal distance, meeting the less than 3 centimetres focal length requirement.

The sample of the ESP-32 CAM tested result as shown in Figure 3b. In addition, the price of this T-Journal module is acceptable (around RM50 per set). By considering the provided features, this camera module achieves the lowest focal length among the surveyed cameras products and can bring up the convenient size handheld Malaysian banknotes reader.



(a)

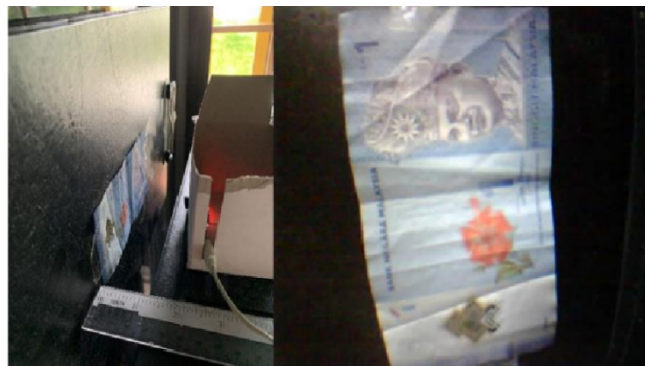

(b)

Figure 3. (a) ESP 32-CAM tested result (b) TTGO T-journal tested result

(ii) Microcontroller

Microcontroller is the essential component in building the Malaysian banknotes reader because it is the center processing unit of the system that controls the inputs, outputs and the data traffic. Although the TTGO T-journal camera module that chosen in the previous sub-section already has a built-in microcontroller, an extra microcontroller is needed due to the TTGO T-journal camera module has insufficient number of pins to support the required inputs and outputs terminals for other components in the Malaysian banknotes reader. Therefore, this embedded microcontroller is required mainly to control the speaker module (discussed in next sub-section) and operates as the bridge to communicate between input buttons and the camera.

The microcontroller selection has significant impact on the banknote reader's software development. For example, an ATmega328p microcontroller has a common Arduino IDE platform that allows users to program the chip. As for the 8051 microcontroller series, the limitation is only having one serial port. Some extra features like image pro-

cessing or image transferring might be hard to implement. PIC is one of the most advanced microcontroller but it is difficult to program and the banknote reader might not need its high end capability because the image processing task is run on the server and not on the banknote reader device itself. So the banknote reader does not require such a high performance processor.

After justifying all the above factors, ATmega328p microcontroller as shown in Figure 4 below is chosen as the main microcontroller for the Malaysian banknotes reader due to its affordable price and the sufficient capability to support the requirement of the Malaysian banknotes detection.

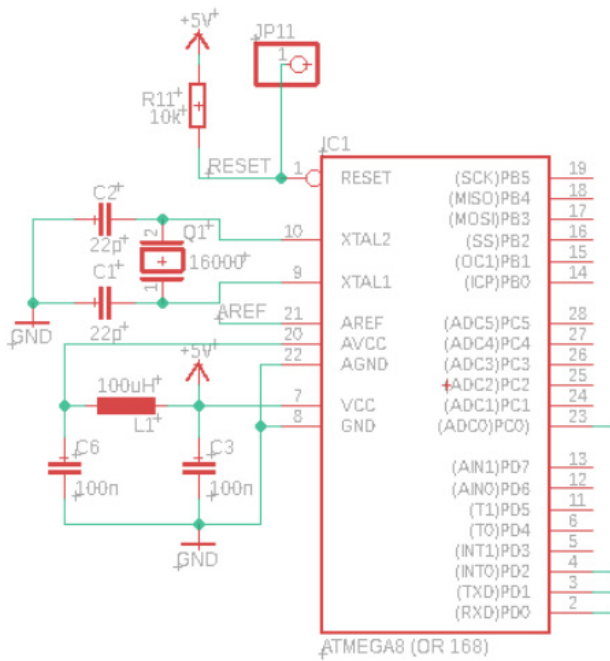

Figure 4. Basic Circuit of a functioning ATmega328p chip

(iii) Speaker Module and Speaker Set

The voice message is the output of the banknote reader to notify visually impaired person about the banknote values, power level and etc. The main consideration of speaker module must have an Integrated circuit that can output the voice message selectively and having an amplifying circuit to ensure that the outputted voice message is loud and clear to the visually impaired person.

The first surveyed speaker module is the ISD1820 voice recording and playback module. This speaker module has a recorder that allows users to pre-record the voice messages and playback accordingly. Once the “REC” button on the speaker module is pressed, the microphone on it will begin to record the sound until the “REC” button is released and the recorded soundtrack will be saved in the Integrated Circuit chip. The main

disadvantage of this speaker module is that it can only store up to 2 soundtracks which is not suitable for the application of Malaysian banknotes detection. For Malaysian banknotes detection, there are at least 6 outputs soundtracks which cover RM1, RM5, RM10, RM20, RM50 and RM100 banknotes. Therefore, this speaker module is not suitable to be selected for the Malaysian banknotes reader.

Next, a DFPlayer Mini MP3 Player module is surveyed. This 2 cm x 2 cm x 1 cm module is small in size and found fit for the Malaysian banknotes reader. Like a MP3 player, this DFPlayer module allows users to choose the preferred soundtracks to be played. The main advantage of this speaker module is that it has a TransFlash card slot and up to 2¹⁶ soundtracks can be selected from the inputted TransFlash card. Furthermore, the DFPlayer module also has a built-in current amplifier to sustain the speaker output, making the output sound loud and clear. Justifying the above advantages, DFPlayer Mini MP3 Player module is chosen as the speaker module for the Malaysian banknotes reader and a 5 Ohm Mono-Stereo type speaker is chosen as the sound displayed speaker. Both of the speaker module and speaker set are shown in Figure 5.



Figure 5. DFPlayer Mini MP3 Player and 5Ohm speaker

(iv) Battery

Portable external DC power supply like alkaline dry cells and power bank are considered for the handheld Malaysian banknotes reader. The benefits of adopting external DC power supply are that the device is portable and the circuits design is simpler with the trade-off of having battery lifetime. A 50000mAh Powerbank is chosen as the power supply for the Malaysian banknotes reader. This is because power bank is easily rechargeable compared to the alkaline dry cells that required frequent change of batteries to support the same usage time. The life cycle of a power bank is also much longer than those alkaline dry cells. This choice is important because the imaging tool and Wi-Fi module required a big amount of power supply during operation. The selected powerbank may support

the banknote reader for 3 to 8 hours of operating time.

(v) White light and UV light

The white light act as a front light and backlight shine on the slotted-in Malaysian banknotes into the reader for the imaging tool to capture a clearer input image. Other than that, on the Malaysian banknotes, there are windowed security thread, peak features and micro-letterings that are only visible when there is a UV light shined on it. However, the UV light is yet to install in the current version of banknote reader.

(vi) Server

The server work as a central hub and centralized image processing tool which manages the access of multiple Malaysian banknotes readers to it with resource (users' personal information, databases of images features for the varieties of Malaysian banknotes etc.)

(b) Software Implementation

The software part of the Malaysian banknotes detection system can be categorised into 4 parts:

Part 1: Camera Module Algorithm (Arduino-based);

Part 2: Microcontroller Algorithm (Arduino-based);

Part 3: Banknote Detection Algorithm (Visual-Basic based);

Part 4: Window Based Server Algorithm (Visual Basic-based) that control the microcontroller interaction with IO, camera, speaker module and window based application.

Part 1, Part 2 and Part 4 of the algorithm and software implementation will be discussed below, whereby Part 3 of the Fuzzy Logic Based Perceptual Image Hashing Banknote Detection Algorithm will be discussed in details in Section 3.

(i) Camera Module Algorithm

The ways of setting up the camera and establishing the connection between the server and camera are demonstrated in this sub-section. ESP 32 can be easily programmed using Arduino IDE. The programming for the T-journal camera module can be split into 3 parts.

Firstly, the camera requires to be initialised by configuring the xclk, pclk, vsync, href and other pins of the camera lens to the ESP 32. This initialisation code might differ with the type of camera lens used. Hence, the code shown in Figure 6 is specially designed for OV2640 type of camera lens. The captured image's file type is set as JPEG format to minimise the transfer time when the captured image is transferred over Wi-Fi. Moreover, the setup of the camera module including the Wi-Fi connection is through the "WiFi.begin" function by providing the information on the network ID and password. The Wi-Fi mode is set as Station mode as a client inside the connected network.

```

camera_config_t camera_config;
camera_config.ledc_channel = LEDC_CHANNEL_0;
camera_config.ledc_timer = LEDC_TIMER_0;
camera_config.pin_d0 = 17;
camera_config.pin_d1 = 35;
camera_config.pin_d2 = 34;
camera_config.pin_d3 = 5;
camera_config.pin_d4 = 39;
camera_config.pin_d5 = 18;
camera_config.pin_d6 = 36;
camera_config.pin_d7 = 19;
camera_config.pin_xclk = 27;
camera_config.pin_pclk = 21;
camera_config.pin_vsync = 22;
camera_config.pin_href = 26;
camera_config.pin_sscb_sda = 25;
camera_config.pin_sscb_scl = 23;
camera_config.pin_reset = 15;
camera_config.xclk_freq_hz = 20000000;
camera_config.pixel_format = CAMERA_PF_JPEG;
camera_config.frame_size = CAMERA_FS_SVGA;

cam.init(camera_config);
f (!WiFi.config(local_IP, gateway, subnet)) {
  Serial.println("STA Failed to configure");
}
WiFi.mode(WIFI_STA);
WiFi.begin(ssid, password);
while (WiFi.status() != WL_CONNECTED)
{
  delay(500);
  Serial.print(F("."));
}
Serial.println(F("WiFi connected"));
Serial.println("");
Serial.println(WiFi.localIP());

```

Figure 6. Camera setup Coding

The second part of the camera module algorithm is to execute the instructions received from the Window-Application Based server, as shown in the flowchart in Figure 7. When the processed image results are received from the server, the instruction handlers in this algorithm will execute the instruction accordingly. For example, when the server forwards a result indicating that the detected banknote is RM10, the instruction handler will transfer this information to the ATmega328p microcontroller so that the "Ten Ringgit" voice message can be displayed on the speaker module.

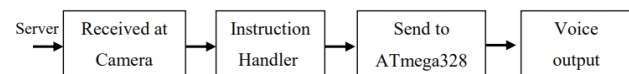

Figure 7. Part 2 of camera module algorithm

In the third part of the camera module algorithm, the camera module was set to not only can receive information from the server, but also from the user too. The camera module is set to have the capability to capture and send the captured banknote image to the server every time the user presses the hardware button. A handler function is created to for the pressed button and guided the status and

captured image to the server. This Part 3 algorithm flow-chart is shown in Figure 8.

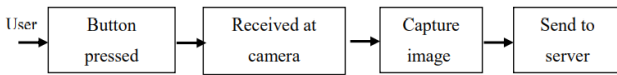

Figure 8. Part 3 of camera module algorithm

(ii) Microcontroller Algorithm

The main microcontroller used for the Malaysian banknote reader is ATmega328p and it is programmed using Arduino IDE platform similar to T-journal camera module in the previous subsection. The difference between ATmega328p and T-journal’s microcontroller (ESP-32) is that ATmega328p is the Master of the system while ESP-32 is the Slave controller to control camera capture images. The microcontroller algorithm (for ATmega328p) here is more focus more on the overall banknote reader system control to coordinate the I/O. In particular, ATmega328p handles the inputs (images received from the T-journal camera, further decoded it and pass to server) and outputs (processed the results received from server, output the corresponding voice message through the speaker module). This subsection is discussed in two parts, in which the first part covers the interface algorithm between T-journal camera (via ESP-32) and ATmega328p and the second part covers the interface algorithm between Speaker module(DFminiplayer) and ATmega328p.

Firstly, due to the lack of Tx/Rx lines in T-journal camera module, the communication between T-journal camera module (via ESP-32) and ATmega328p microcontroller is not through standard serial communication ports. Hence, by using the 3 I/O pins both from the T-journal camera module and ATmega328p, a three-lines decoder system is created. The reason for using 3 lines is because the maximum total number of instructions/results that are passed from T-journal camera module to ATmega328p is 8. This number is calculated by taking 2 to the power of number of line which is $2^3 = 8$. The truth table for the line setting is shown in Table 1. In coding way, this 3 Line Decoder is built using a nested if-else loop to check each of the 3 inputs line constantly. However, the instruction will be only executed once every time it received the instruction.

Table 1. Truth table for the 3Line-Decoder

First Line	Second Line	Third Line	Instruction
0	0	0	No Banknote is detected.
0	0	1	RM20 is detected.
0	1	0	RM5 is detected.
0	1	1	RM100 is detected.
1	0	0	RM1 is detected.
1	0	1	RM50 is detected.
1	1	0	RM10 is detected.
1	1	1	Camera Module is connected and ready.

Next, the algorithm for the interface between ATmega328p and DFminiplayer speaker module is constructed by using the DFPlayer_Mini_Mp3.h library. This library can be worked on the Arduino IDE platform and it is cost free, supplied by the DFminiplayer manufacturer. The speaker module setup is simple, in which the baud rate for ATmega328p microcontroller is set to be 9600 to match the DFminiplayer. After that, a function named mp3_set_serial is called to set the DFminiplayer to be in serial mode. The setup is done and mp3_play can be used to play the soundtrack saved in the TransFlash card by specifying its numbering. Other than that, mp3_set_volume also can be used to adjust the output volume and the default volume is set at level 20. For the Malaysian banknote reader, the sound volume is to be set at level 35 to ensure a clear and loud output voice to the visually impaired person.

(iii) Window Based Computer Server Algorithm

A Window based application software is formulated using Visual Studio Basic to act as a window based computer server for the Malaysian banknotes reader. The Window based computer server mainly uses to receive those captured banknote images from the banknote reader, performed image processing on those images and return the results. This Window based application software is expected to have the ability to communicate between banknotes reader and the computer to perform banknote detection.

A simple blank project of Window Form Application named “Malaysian Banknote Reader System” with two button “Start” and “Stop” is created using Visual basic. The idea behind this simple program is when start button is pressed, the server will start to detect if there is any instruction sent from the banknotes reader while the stop button will stop the operation of the server immediately. If the button on the hardware is pressed, the server will be notified and it will send a response back to the banknotes reader to request for the captured image. Then, the captured image will be sent back to the server and saved in the computer. Most importantly, the mechanism behind sending the instruction to the hardware is through the IP address of the device by using an HTTP GET Request Method. This GET Request is a method of sending request to targeted IP address along with some extra information and wish to get reply from the client.

If the button is pressed, the function “StreamReader” will store and display the response in textBox1. For example, “Pressed” or “NotPressed” will be displayed on the textBox1. This is for debugging purpose. Then, the response must be closed to ensure that the delay time is as minimal as possible. If the response is not closed every

time a connection is established, it will cause the server to be very laggy and buggy. When the button status in the textBox1 is changed to “Pressed”, a request will be sent back to the banknote reader to request for the captured image. Then, “/jpeg” will be added behind the IP address of the banknote reader to request for the captured banknote image. This image will then be stored in the computer as jpeg file type. After saving the captured image, the server will start to perform the banknote detection algorithm as in Section 3.

This is done through the function of Image Hashing which include the Step 1 to Step 5 in Section 3. The threshold value is set to 90 as highlighted. The Step 6 in Section 3 is for the implementation of fuzzy rules are done through the If-Else loop. Then, the result will be sent back to the hardware by encrypting the information behind the IP address. For instances, if the defuzzified result is RM50, then “/RM50” will be added behind the IP address of the hardware and perform GET request. Nevertheless, the results can be treated as individual instruction to “ask” the hardware to produce the voice output accordingly. Hence, 6 more buttons are created for debugging purpose of the results sending functions. In simpler word, the result is sent just by calling one of the buttons, in this case the RM50 button to produce a RM50 voice output from the hardware.

Lastly, a pictureBox1 is added to display the captured image received from the hardware. The complete appearance of the Window based application graphical user interface (GUI) is shown in Figure 9 and a test of a RM20 banknote tested sample is shown in Figure 10.

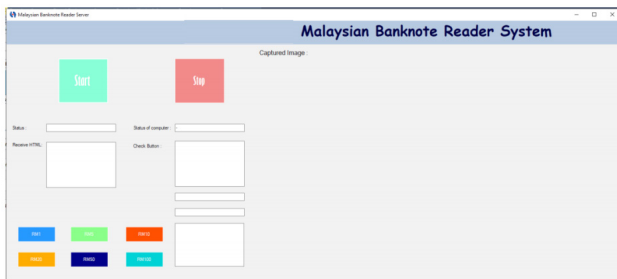

Figure 9. Final window based server with GUI

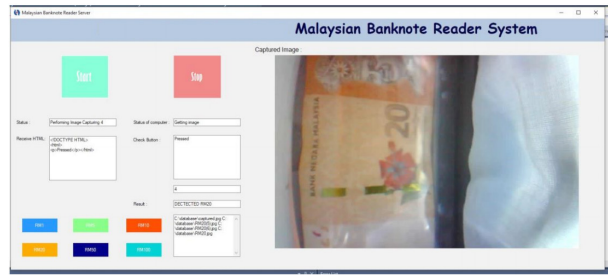

Figure 10. A RM20 Banknote Tested Sample on GUI

3. Fuzzy Logic Based Perceptual Image Hashing Algorithm in Malaysian Banknotes Detection

In this section, Perceptual Image hashing algorithm [10] is used in addition with fuzzy logic to assist the final banknotes value’s decision making. The purpose for adopting Perceptual Image Hashing algorithm rather than standard feature extraction methods is that Perceptual Hashing may enable the potential of this banknotes reader to reach the international level. In future, this banknotes reader able to detect other countries’ banknotes easily by just including more other countries banknotes samples into the database. Moreover, the hash functions in the Perceptual Hashing are analogous if the matching images are similar. The input image and database stored images are matched in term of their perceptual content.

The flowchart of the Fuzzy Logic based Perceptual Image Hashing algorithm for Malaysian banknotes detection is shown in Figure 11 and the algorithm can be explained in 8 steps as listed below:

Step 1: Setup Database

Capture a number of Malaysia Banknotes (RM1, RM5, RM10, RM20, RM50 and RM100) with different rotation/orientation and store as the database in the computer server.

Step 2: Sort Database using Perceptual Image Hashing Algorithm

Resize all the images stored inside the database. Gen-

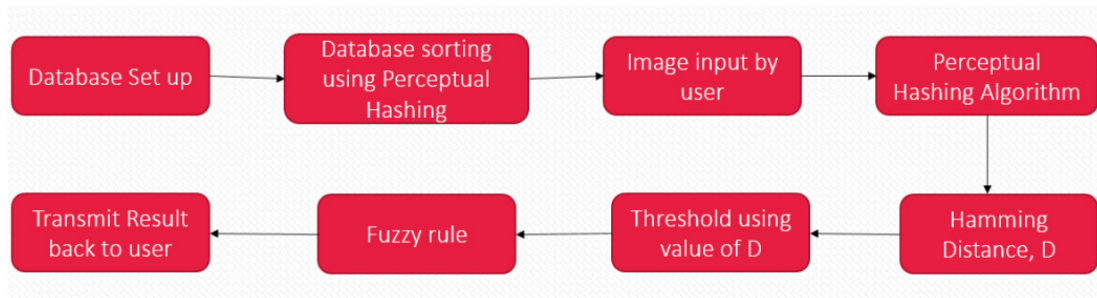

Figure 11. Flowchart for Fuzzy Logic based Perceptual Image Hashing Algorithm

erate hash code for each of the resized images in the database using Perceptual Image Hashing algorithm [10]. Sort the newly generated perceptual hash codes alphabetically in the database.

Step 3: Input Image

When the button on the banknote reader is pressed, banknote reader will capture the image of the banknote inserted by the user and transmit the image to the computer server.

Step 4: Perform Perceptual Image Hashing

Perform Perceptual Image Hashing on the inputted image. A RM100 banknote sample shown in Figure 12 is used as the source image for demonstration purpose for each sub-steps.



Figure 12. A Sample of RM 100 Banknote

(i) Convert the received inputted image to grayscale image and resize it to 1024 x 512 pixels, as shown in Figure 13.

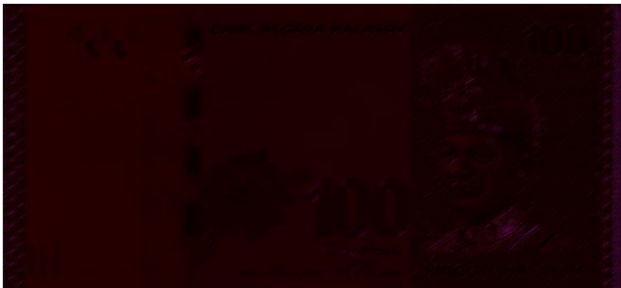

Figure 13. Grayscale and Resized RM100 Banknote

(ii) Filter the grayscale image using Gabor filter [14] for frequency and orientation representation. The sample image is shown in Figure 14.



Figure 14. Gabor filtered RM100 Banknote

(iii) Perform Discrete Cosine Transformation (DCT) using the Equation (1):

$$DCT : X_k = \sum_{n=0}^{N-1} 2n * \cos \left(\Pi * k * \frac{2n+1}{2N} \right) \forall k \in [0, N] \quad (1)$$

(iv) Extract the RGB (Red, Green and Blue) components and calculate the RGB mean block using the Equation (2):

$$RGB \text{ mean} = \frac{\sqrt{R^2 + G^2 + B^2}}{3} \quad (2)$$

(v) By using the top left block of the image, a hash value is generated from the RGB mean. This is because the highest frequency block is always normalized and placed at top left corner as shown in Figure 15.



(I) Source Image (II) Top left Block (DCT)

Figure 15. RM100 Banknote after Performed DCT

Step 5: Threshold using Hamming Distance

(i) Generate a hash value, x as an input and compare it with those hash values stored in the database, $y_n (y_1, y_2, y_3 \dots)$ by computing the identical percentage, P from the Hamming Distance, D of x and y_n using the Equation (3):

$$D = \min \{ d(x, y) : x, y_n \in C, x \neq y \} \quad (3)$$

Perceptual hashing is applied to map the images, in term of their perceptual content.

(ii) If the captured image is almost identical to the images in database, the identical percentage, P shall be around 90%~99%. Hence, the threshold, T for this project is set at 90% (obtained from Section 4 experimental results).

Step 6: Result Classification Using Fuzzy logic

(i) There can be more than one images in the database that can exceed the threshold value T , and be treated as identical image due to the perceptual distance between the same values banknotes' images with different orientations are extremely close to each other.

(ii) Eventually, a single banknote can have up to four orientation combinations, together with the front and back view. Therefore, fuzzy logic rules are needed to classify the result and perform decision making after the input P is fuzzified:

Number of Rules	Condition of Rules
Rule 1	IF <u>either one</u> of the $P, D(x,y_n) > 0.9$, the input image is identical to one of database images, THEN set output, $O = 1$.
Rule 2	IF <u>more than 3P</u> are between the range of $0.8 < D(x,y_n) < 0.9$, then the input image is identical to one or more of database images, THEN set output, $O = 0.5$.
Rule 3	IF <u>all</u> of the $D(x,y_n) < 0.8$, then the input image is not identical to any of the database images, then set output, $O = 0$

(iii) The output, O is then defuzzified. If the defuzzified O is greater than 0.5, a conclusion is made that the input banknote image is identical to one or more of the database image can be drawn. Else, if defuzzified O is smaller than 0.5 a particular database image, it can be concluded that there is no identical image in the database and hence the value of banknote cannot be detected.

Step 7: Result Transmission

(i) If there are identical database images detected in step 6, then the name of the identical database image will be checked. The reason is the banknote images in database are all saved in such a way that the name itself is the value of the banknote. Hence, if defuzzified $O > 0.5$, the name of the highest identical percentage image will be sent to the hardware through Wi-Fi communication. Then, the microcontroller in the hardware will decode the information and play the soundtrack that indicates the value of the detected banknote.

(ii) If there is no identical database image detected in step 6, as defuzzified $O < 0.5$, then the information containing “Banknote Not Recognized” will be sent to the hardware through Wi-Fi communication. Similarly, the microcontroller will control the DFminiPlayer to output the soundtrack to indicate the input banknote is not recognized.

Step 8: Increasing the Precision and Accuracy

Towards increasing the precision of the banknote detection and to include the learning capability for the banknote detection system, the current input image will later be stored in the database to increase the sample size of the database, after the current input image is confirmed as one of the banknote in step 6 and 7. Consequently, the error due to luminance and brightness of the coming input image can be minimized.

4. Experimental Results

The final prototype for the proposed Malaysian banknote reader is constructed, as shown in Figure 16. A number of experiment tests have been conducted to find for the optimum parameters introduced in the algorithm and to conduct performance evaluation under the optimum setting. The significant parameter that eventually influence the performance of the algorithm is the threshold value, T .

If T is set too low, the banknote value identification cannot be done since there will be plenty of database images found to be identical to the input image. This will cause a spike in the banknote detection system as the failure rate to recognize the correct banknote value increases tremendously, as shown in the performance curve in Figure 17.

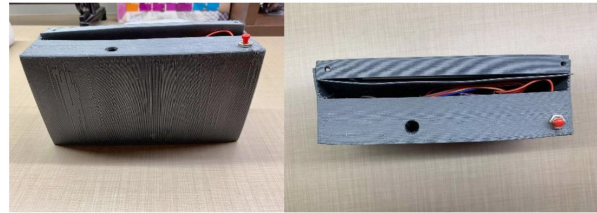

Figure 16. Malaysian Banknote Reader Prototype

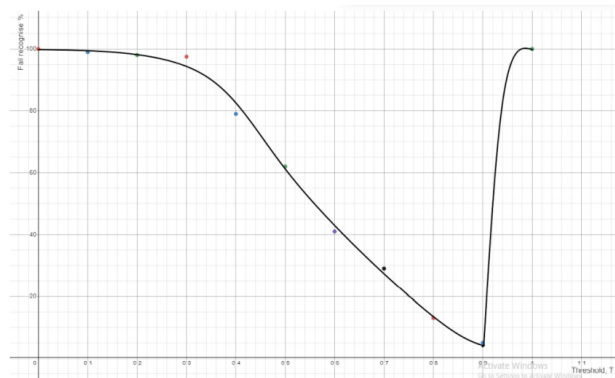

Figure 17. Graph of Failure Rate vs Threshold T

From the experiment result in Figure 17 tested on 100 trials (RM100 banknote as sample) for each of the different T value set, the optimum threshold value, T is at 0.9 and therefore $T = 0.9$ or 90% was set for Step 5 (ii) in Section 3. An experiment is carried out to test the accuracy and efficiency of the developed Malaysian banknote reader. 100 pieces for each RM1, RM5, RM10, RM 20, RM50 and RM 100 Malaysian banknotes were tested with the developed Malaysian banknote reader with the set Threshold, $T = 0.9$. The corresponding banknotes recognition results are shown in Table 2.

Table 2. Banknotes Recognition Results using Malaysian Banknotes Reader

100 pieces sample of	Successful recognize	Fail recognize	Mistreat as other currency value	Unable to detect
RM1	95	5	2	3
RM5	96	4	0	4
RM10	93	7	7	0
RM20	92	8	6	2
RM50	96	4	4	0
RM100	98	2	0	2

The average successful recognition rate for the Malay-

sian banknotes detection system is about 95%, that covered 570 successful trials out of 600 total trials. Among the tested Malaysian banknotes, RM100 has the highest successful recognition rate of up to 98%, whereas RM10 has the highest mistreat rate (7%) among the six classes of Malaysian Banknotes. The reason could be caused by RM10 and RM20 are having almost identical colour group (in red and orange respectively). Red is often mistreated as orange, due to orange colour also consists of red colour components. This situation becomes obvious especially in low light environment. In addition, according to the obtained results, RM5 is the hardest banknote type to be detected (having the most unable to detect attempts). This could be due to the RM5 banknotes material is polymer type of material that will slightly reflect light from the light source.

The Malaysian banknote reader hardware's response time was measured. On average, it took about 480ms to 560ms for a Malaysian banknote to be recognized by the server. The overall process times is around 3 seconds in total, this include the time for the banknote image to be get captured by the camera and sent through Wi-Fi, the time required for image processing and evaluate the results(recognition), as well as the time to return the results to the Malaysian banknote reader for displaying the banknote value's voice message to the visually impaired person.

The Malaysian banknotes detection system was also tested with some visual impairment users to study the feasibility of usage and the conveniences. A total of 45 visually impaired participants, including 17 visually impaired persons from the Melaka town areas and 28 visually impaired members from Society of Blind Malaysia (SBM) with ages ranging from 18 to 70 years old had been participated in testing the Malaysian banknotes detection system prototype. Some photos during the experiments carried out time were captured, as shown in Figure 18.



Figure 18. Photos During the Experiments Carried Out

In order to measure the hands on time consumption by the visually impaired person, each visually impaired participant was instructed to attempt 100 times of banknote detection tasks. It consumed an average of 10.518 minutes for the task completion by the visually impaired participants. The same test was also conducted with 45 visually good participants to run a fair comparison. On average, these 45 visually good participants took 1.8 minutes faster than the visually impaired participants (around 8.7 minutes) to complete the same task. Analysing the result, there is only a slight difference of 1.0908 second among each banknote reading time between the visually good participants and the visually impaired participants. The results are comparable, proven that the proposed Malaysian banknote detection system is feasible for visually impaired persons in helping them to read the Malaysian banknotes.

During the experimental and survey section, the visually impaired participants also provided some constructive suggestions and recommendations for the improvement to the current Malaysian banknote reader:

1) The size of the banknote reader: Can be made even smaller than the current prototype so that it is even easier to be carried around by users.

2) Battery level voice indication: Currently there is no method for the visual impairment person or even visually good person to know the battery level. Users will never know the banknote reader is still functioning or not, due to lack of power or malfunction. It is suggested by the survey participants to add some techniques like voice indication to inform the user about the current battery level.

5. Conclusions

A Malaysian Banknote Reader and Detection system is successfully developed and presented in this paper. The Malaysian Banknote Reader is able to capture the inserted banknote image when the button placed on the reader is pressed. There is a computer server prepared to receive the captured image through Wi-Fi connection from the Malaysian Banknote Reader. This computer server is holding a database of Malaysian Banknotes images with different values and different rotation/orientation, adopting the perceptual image hashing algorithm to map the input banknote image to correct banknote image in the database. Fuzzy logic classifier is used to make the final decision of the banknote value result, before sending the result back to the Malaysian banknote reader to inform the user about the Malaysian banknote value. A speaker module placed inside the banknote reader hardware is able to output the verbally result as this is to no-

tify the visually impaired user. A user friendly graphical user interface (GUI) is also created using Visual Basic to provide a simple platform for the users to check the status on the computer server.

The main contribution of this Malaysian Banknote Reader and Detection system is to aid the virtual impaired person deal with money transaction in their daily business. The product can help the visually impaired person detecting the value of the Malaysian banknotes so that they will not get cheated easily during trading. The biggest challenge of this prototype development is to have a very small size banknote reader that is convenient to be carried around. The current prototype size is still large and it has room for improvement provided surface mounted electronics components is selected. A better imaging tool can be sourced so that the focal distance can be smaller to reduce the gap of the banknote and camera, hence reduce the size of the final product.

The issue of Internet Protocol (IP) address for the prototype is still a big problem due to the inconveniences for the visually impaired users to keep track of their IP address if they are continuously changing their internet network. This is because the computer server might work in the ways with a fix and known IP address. The solution to solve this is rather simple but cost expensive because it might require a static server for the information fetching between host and client so that the IP address can be remained static. A static server is quite expensive at this moment. Another alternative is by improving the window based program to the way that the user is able to change the network from time to time and from place to place without modifying the hardware program. This method is very tedious as the microcontroller should be programmed in such a way that it can always keep track of the network data that are sent by the user through T-Journal camera.

As for software recommendations, in future, the Malaysian banknotes reader and detection system can be improved to detect the genuineness of the banknotes. The current version of the Malaysian banknotes reader and detection system only can detect the value of the Malaysian banknotes, not the genuineness or counterfeit of the Malaysian banknotes. The users of the Malaysian banknotes reader cannot know whether the banknote inserted is a real or a fake banknote. To solve this issue, the image processing algorithm can be improved to detect the security features that are hidden in the Malaysian banknotes. For example, there are watermarks like windowed security thread, micro-letterings and peak features that are only visible when there is a backlight, front light and UV light shined on the banknotes.

Feature extraction image processing method ^[15] can also be implemented into the banknotes detection algorithm to increase the performance of the banknote's value detection. For example, the numeric wording on the Malaysian banknote itself can be captured and process to aid the fuzzy logic conclusion making. Moreover, the fuzzy logic system can also be improved to an Artificial Intelligent Based System ^[16] that is able to improve the performance of the banknote detection algorithm.

All in all, the critical areas of future research shall focus on reducing the size of the product as well as adding the counterfeit detection for the banknotes. The database of the system can also be expended in such a way that multiple countries banknotes can also be detected.

Acknowledgement

This project is made possible by Fundamental Research Grant Scheme (FRGS) 2020 (FRGS/1/2020/ICT06/MMU/02/1), Ministry of Higher Education Malaysia.

References

- [1] S. C. Reddy, T. Thevi, "Blindness and low vision in Malaysia," *International Journal of Ophthalmic Research*, vol. 3, no. 2, pp. 234-238, 2017.
- [2] S. P. Khanal, K. P. Acharya, P. Uprety, S. K. Shah, "Statistical Modeling on Blindness and Visual Impairment Data," *Journal of Institute of Science and Technology*, vol. 19, no. 1, pp. 1-6, 2014.
- [3] T. M. e. al, "The Eurosystem's efforts in the search for a longer lasting banknote," *Billetaria*, no. 9, 2011.
- [4] N. A. Semaary, S. M. Fadl, M. S. Essa, A. F. Gad, "Currency Recognition System for Visually Impaired: Egyptian Banknote as a Study Case," in *IEEE 2015 International Conference on Information and Communication technology and Accessibility, ICTA*, Morocco, 2015.
- [5] H. d. Heij, "Durable Banknotes: An Overview," in *Presentation of the BPC/Paper Committee to the BPC/General Meeting*, Prague, 2002.
- [6] Quintero, "Evaluation of Long Lasting Papers for Venezuelan Banknotes," in *XVII Pacific Rim Banknote Printers' Conference*, 2005.
- [7] V. Alevan, E. A. McLaughlin, R. A. Glenn and K. R. Koedinger, "Instruction based on adaptive learning technologies". In: *Handbook of Research on Learning and Instruction*, Routledge, 2016.
- [8] S.Y. Lin, J.Y. Chen, J. C. Li, W. Y. Wen, S. C. Chang, "A novel fuzzy matching model for lithography hotspot detection," in *IEEE/ACM Design Automation Conference (DAC)*, 2013.
- [9] D. Raychaudhuri and N. B. Mandayam, "Frontiers of

- Wireless and Mobile Communications," Proceedings of the IEEE, vol. 100, no. 4, pp. 824-840, 2012.
- [10] T. K. B. Das, "A Secure Image Hashing Technique for Forgery Detection. In Distributed Computing and Internet Technology", Lecture Notes in Computer Science; Natarajan, R., Barua, G., Patra, M.R., Eds.; Springer: Cham, Switzerland, 2015; Volume 8956, p.p. 335-338.
- [11] H. Yang, J. Yin and M. Jiang. "Perceptual Image Hashing Using Latent Low-Rank Representation and Uniform LBP". *Applied Sciences*. 2018; 8(2):317 p.p 1-12.
- [12] C. S. Lu and C. Y. Hsu "Geometric distortion-resilient image hashing scheme and its applications on copy detection and authentication". *Multimedia Syst.* 2005, 11, p.p. 159-173.
- [13] L. A. Zadeh, *Fuzzy Sets, Fuzzy Logic, Fuzzy Systems*. World Scientific Press , 1996.
- [14] A. P. Pujiputra, H. Kusuma and T. A. Sardjono, "Ultraviolet Rupiah Currency Image Recognition using Gabor Wavelet," 2018 International Seminar on Intelligent Technology and Its Applications (ISITIA), 2018, pp. 299-303.
- [15] J.-R. Gao, B. Yu, and D. Z. Pan, "Accurate lithography hotspot detection based on pca-svm classifier," *Proc. of SPIE*, 2014, p.p. 90530E 1-10.
- [16] V. Aleven, E. A. McLaughlin, R. A. Glenn, K.R. Koedinger. "Instruction based on adaptive learning technologies". In: *Handbook of Research on Learning and Instruction*, Routledge, 2016.