

ARTICLE

Quantum Algorithm of Imperfect KB Self-organization. Pt II: Robotic Control with Remote Knowledge Base Exchange

A.G. Reshetnikov¹ S.V. Ulyanov^{2*}

1. Plekhanov Russian University of Economics, Laboratory of cloud technologies and Big Data analytics, Russia

2. State University Dubna, Russia

ARTICLE INFO

Article history

Received: 18 October 2021

Accepted: 21 October 2021

Published Online: 28 October 2021

Keywords:

Quantum software engineering

Quantum algorithm

Group of intelligent robots

Multi-agent system

Intelligent control

Fuzzy controller

Remote transmission of knowledge

Knowledge synergetic

ABSTRACT

The technology of knowledge base remote design of the smart fuzzy controllers with the application of the "Soft / quantum computing optimizer" toolkit software developed. The possibility of the transmission and communication the knowledge base using remote connection to the control object considered. Transmission and communication of the fuzzy controller's knowledge bases implemented through the remote connection with the control object in the online mode apply the Bluetooth or WiFi technologies. Remote transmission of knowledge bases allows designing many different built-in intelligent controllers to implement a variety of control strategies under conditions of uncertainty and risk. As examples, two different models of robots described (mobile manipulator and ("cart-pole" system) inverted pendulum). A comparison of the control quality between fuzzy controllers and quantum fuzzy controller in various control modes is presented. The ability to connect and work with a physical model of control object without using than mathematical model demonstrated. The implemented technology of knowledge base design sharing in a swarm of intelligent robots with quantum controllers. It allows to achieve the goal of control and to gain additional knowledge by creating a new quantum hidden information source based on the synergetic effect of combining knowledge. Development and implementation of intelligent robust controller's prototype for the intelligent quantum control system of mega-science project NICA (at the first stage for the cooling system of superconducted magnets) is discussed. The results of the experiments demonstrate the possibility of the ensured achievement of the control goal of a group of robots using soft / quantum computing technologies in the design of knowledge bases of smart fuzzy controllers in quantum intelligent control systems. The developed software toolkit allows to design and setup complex ill-defined and weakly formalized technical systems on line.

**Corresponding Author:*

S.V. Ulyanov,

State University Dubna, Russia;

Email: ulyanovsv46_46@mail.ru

1. Introduction: Self-organized Smart Control in Advanced Intelligent Robotics

The PID controller is distinguished as the most common form of feedback: more than 95% of the control feedback-loops are of PID type. These controllers can be found in all areas where control is used. Despite its straightforward structure, the popularity of PID controllers lies in the simplicity of the design procedures and in the effectiveness obtained to the system performance. Therefore, the beauty of the proportional-integral-derivative (PID) algorithm for feedback control is in its nature simplicity and efficiency. Those are the main reasons why PID controller is the most common form of feedback. PID – controller combines the three natural ways of taking into account the error: the actual (proportional), the accumulated (integral), and the predicted (derivative) values. The mentioned three gains depend on the magnitude of the error, the time required to eliminate the accumulated error, and the prediction horizon of the error. Those are the main reasons why PID controllers have survived many changes in technology, from mechanics and pneumatics to micro-processors via electronic tubes, transistors, integrated circuits, among others and applied as executive control level in projects^[1] of “Industry 4.0” with Industrial AI.

Remark. The advent of the Industry 4.0 initiative has made it so that manufacturing environments are becoming more and more dynamic, connected but also inherently more complex, with additional inter-dependencies, uncertainties and large volumes of data being generated. Recent advances in Industrial AI have showcased the potential of this technology to assist manufacturers in tackling the challenges associated with this digital transformation of Cyber-Physical Systems, through its data-driven predictive analytics and capacity to assist decision-making in highly complex, non-linear and often multistage environments. However, the industrial adoption of such solutions is still relatively low beyond the experimental pilot stage, as real environments provide unique and difficult challenges for which organizations are still unprepared. A set of key challenges and opportunities to be addressed by future research efforts are formulated along with a conceptual framework to bridge the gap between research in this field and the manufacturing industry, with the goal of promoting industrial adoption through a successful transition towards digitized and data-driven conventional controllers on executive control levels.

Actually, practically all PID controllers made today are based on microprocessors, so this nanoelectronics element has had a dramatic influence on this kind of control providing PIDs additional advances features for “Industry

4.0”, such as gain scheduling, continuous adaptation, and automatic tuning. The quantum self-organization algorithm model of wise knowledge base design for hybrid intelligent fuzzy PID - controllers with required robust level considered in^[2,3].

Problems of advanced control system design. From the advanced control engineering point of view, improving system robust behavior is the major concern. To that end, the generalization of classical PID controllers to non-integer orders of integration and differentiation was proposed. Intuitively, with this extension of classical PIDs there are more tuning parameters and, consequently, more flexibilities in adjusting time and frequency responses of the control system. This also translates in more robustness in designs. However, the first step when applying an existing or new controller is to understand exactly what their actions can do in closed-loop in order to take full advantage of the possible effects on the system response. In the case of integer order, the interpretation of the three actions of PIDs seems to be clear: the proportional action is simply proportional to the current control error; the integral action is related to the past values of the control error, so represents the accumulated error, i.e., the area under the error curve; the derivative action predicts future values of the error or, in other words, corrects based on the rate of change of the deviation from the set-point.

The key aspect when tuning PID controllers is in deciding how to best combine those three terms to achieve the most efficient regulation of the process variable for the considered problem. As well known, the most obvious way is to use a simple weighted sum where each term is multiplied by a tuning constant or gain, and the results are then added together as follows: A new design of n^{th} order binomial filters has shown that an appropriately tuned filtered PID control may yield faster closed-loop transients by producing a less excessive control effort than an optimally tuned PI control. These made it possible to deal, for example, with controllers using higher order derivative actions and to show them attractive also in control of the time-delayed systems. Physically, as example, PIDD² controllers offer position, velocity and acceleration feedback useful in dealing with systems not allowing rapid output changes, when the loop behavior depends significantly on the previous control history. Since an analytical optimal design of four parameters of a PIDD² controller, which, in addition, requires appropriate implementation filters to represent a highly complex problem, different alternative approaches as, for example, the particle swarm optimization have been tested.

Different approaches to design of expanded conventional controller’s structures in^[4-9] described. In compar-

ison with the much simpler PI control, which still attracts attention of the contemporary research, the design is yet more complicated also due to the fact that an increased speed of transients exhibits all modeling and tuning imperfections. This task is intractable problem in advanced control system design.

Figure 1 demonstrates the structure of information technology design of intelligent control systems based on quantum soft computing.

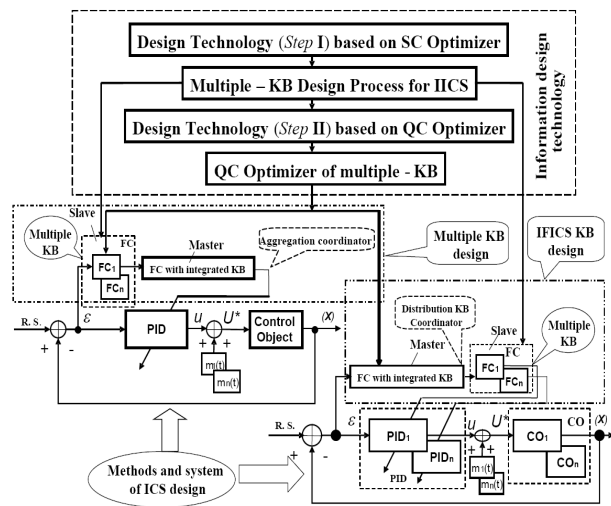

Figure 1. Main steps of intelligent control system design.

Background of the model representation is a new model of quantum inference based on quantum genetic algorithm [2]. Quantum genetic algorithm applied on line for the quantum correlation's type searching between unknown solutions in quantum superposition of imperfect knowledge bases of intelligent controllers designed on soft computing toolkit. Disturbance conditions of analytical information-thermodynamic trade-off interrelations between main control quality measures (as new design laws) discussed. The smart control design with guaranteed achievement of these trade-off interrelations is main goal for quantum self-organization algorithm of imperfect KB. Sophisticated synergetic quantum information effect (autonomous robot in unpredicted control situations and swarm robots with imperfect KB exchanging between "master – slaves") introduced. A new robust wise controller designed on line from responses on unpredicted control situations of any imperfect KB applying quantum hidden information that extracted from quantum correlation. Within the toolkit of classical intelligent control, the achievement of the similar synergetic information effect is impossible.

Physical interpretation of this new quantum supremacy effect in system of system engineering introduced. Bench-

marks of intelligent cognitive robotic control applications considered. The role of information extremum and free energy principles in quantum self-organization imperfect KB of smart fuzzy controllers with imperfect KB discussed.

2. Problem Statement: Main Tasks

Under conditions of uncertainty or inaccuracy of the initial information, unforeseen situations or information risk, the conventional (using the principle of global negative feedback) and industry-wide PID controller often fails to cope with the control task. At the same time, there is no solution to the problem of the global robustness of the PID controller so far, despite the urgency of this problem. The application of fuzzy controller (FC) in combination with a PID controller led to the creation of hybrid fuzzy ICSs with different levels of intelligence, depending on the completeness and correctness of the designed knowledge base (KB). This allowed to improve the quality of control, but doesn't completely solve the problem of robust control in unforeseen situations. The application of the soft computing technology (based on the genetic algorithms, neural networks and fuzzy logic) has expanded the areas of effective use of PID with FC by adding new functions in the form of teaching and adaptation.

The application of quantum computing technologies (based on quantum deep machine learning with quantum neural network and quantum genetic algorithms) finds the solution to the above mentioned problem of the global robustness of the PID controller so far, despite the urgency of this problem.

This article considered a network of loosely coupled groups of robots working together to solve tasks that go beyond individual capabilities, and individually the elements don't implement the difficult task. Different and information nodes of such a system, as a rule, have a different level of computational intelligence (knowledge, algorithms, and computational bases) and various resources in designing. Each node should be able to modify its behavior depending on the circumstances, as well as to plan its communication and cooperation strategies with other nodes. Here the indicators of the level of cooperation are the nature of the distribution of tasks, the unification of various information resources and, of course, the possibility of solving a common problem in a given time [2,3]. Typical examples of the interaction of such robotic systems are the tasks of object recognition and manipulation, control when moving along an optimal trajectory, route planning, stabilization of dynamically unstable systems (for example, an inverted pendulum), control of multi-link manipulators, when implementing hierarchical and decentralized

control in a group of robots [10-18].

In this work, to demonstrate the interaction of the robotic systems, the robot's models were designed - inverted pendulum and mobile platform with navigation, manipulator and stereo vision system (see, Figure 2). The robot control systems operate on the basis of quantum fuzzy controllers that were developed using the technology presented below [19-21]. In particular, solving the task of controlling executive mechanisms, electric motors in coordination control and navigation systems, are used, above mentioned conventional PID - controllers.

The developed intelligent toolkit as Quantum Soft Computing Optimizer (SCO) of Knowledge Base (QSCOptKB™) [19,22,23] allowed to design robust KBs applying the solution of one of the problems of the theory of artificial intelligence difficult to solve algorithmically - extraction, processing and formation of the objective knowledge without expert estimates.

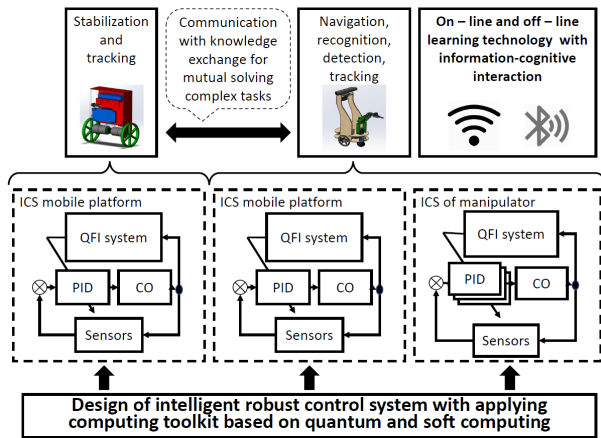

Figure 2. A two-dimensional model of an inverted pendulum and mobile manipulator.

[here CO – control object, QFI – quantum fuzzy inference, ICS – intelligent control system]

In this SCO, three GAs are used that allow designing an optimal structure of a FC (the type and number of the MFs, their parameters, and the number of fuzzy inference rules), that approximates the teaching signal with the required error. In this case, the teaching signal can be obtained directly from the control object functioning in the learning mode. At the same time, an optimal structure of the fuzzy neural network is automatically designed and a model is formed of the universal approximator in the form of a fuzzy controller with a finite number of production fuzzy logic rules in the KB.

SCO on soft computing is a new effective software tool for KB design of robust ICS applying the presented criteria on the basis of information and thermodynamic

measures of entropies. Structurally, SCO consists of inter-related genetic algorithms (GA₁, GA₂, GA₃) that optimize individual components of KB [1]. The basic optimization steps and the structure of the SCO are shown in Figure 3.

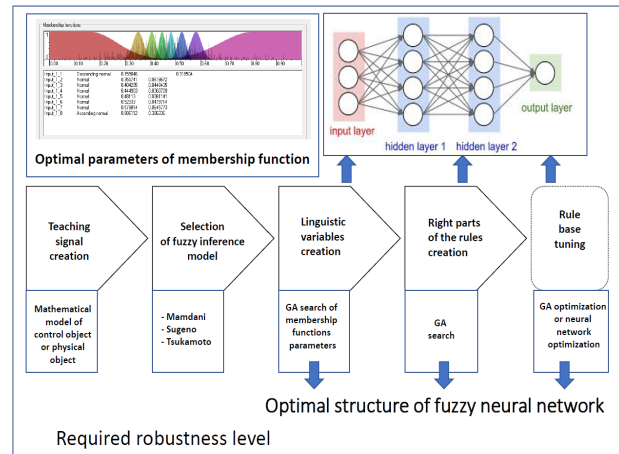

Figure 3. Main stages of the knowledge base design on Soft Computing Optimizer (SCO).

Block FC is the central element of the ICS (Figure 1) and generates control signals of the time-varying (control laws) gain factors, (k_p, k_i, k_d) (coefficient gain schedule) of the PID controller, applied to stabilize an inverted pendulum, mobile platform control and manipulator control. The functional structure of the ICS with FC and SCO blocks on soft and quantum computing is shown in Figure 3.

At the same time, the sources of teaching signals (TS) are on the one hand the physical environment measured by sensors with the ability to influence it with actuators and translate the system into the required state; on the other hand, the information (including model) representation of individual systems functioning among themselves with the set accuracy of approximation.

Key stages of knowledge extraction from physically measured control signal and teaching with reinforcement are hardware and software implementation of such algorithm, which allows to extract and form KB of cognitive-intelligent controller, while connecting to the CO on all stages of KB design. In the process of knowledge extraction, the classification of input control situations and verification of control actions on the CO is carried out. The learning process itself causes the expenditure of physical resources and a decrease in the quality of control, by checking the various trajectories of control and commands, while the information environment forms the structure of the KB. Note that in the space of the formed solutions, all the features of the physical implementation of the system (noise, backlash, errors in the manufacture of parts and environmental conditions) are taken into

account. As a result, imperfect data in TSs - resource in the learning process is compensated by knowledge, formalized in the form of KB, while laying the accuracy and reliability of control in the learning situation, taking into account the physical characteristics of the system.

Modeling the behavior of the system, firstly, allows to expand the class of problems solved by increasing the number of simulated situations (changes in mass, friction, various kinds of noise sensors and modeling the influence of the environment), and secondly, provides the ability to search for optimal trajectories in given situations modeling. However, the previous process of verification and identification of the model, as well as the process of search and approximation of optimal trajectories in the KB, require significant computational resources and strongly depends on the level of complexity of the described system, its correctness, the number of structural elements and connections between them. Moreover, in the case of unforeseen situations-not inherent in the KB ICS, the application of such an approach will cause significant time delays in the feedback loop, which is quite critical from the point of view of control of these systems.

Let us consider the problem of maintaining a constant pressure and in a liquid nitrogen collector on an experimental setup designed to control the manufactured superconducting (SC) magnets of the complex apply SCO based on soft computing and SCOptKB™ toolkit (Figure 3).

Example: Intelligent robust liquid nitrogen flow control system in the collector of a cryogenic plant for control of superconducting magnets.

By controlling the nitrogen supply valve, it is necessary to regulate the pressure and flow rate of nitrogen in the collector. The control loop status is monitored by a pressure sensor and a nitrogen level sensor. In this state of superconductivity, the magnet winding must be maintained at the equilibrium point of the permissible range of changes in current, temperature and magnetic field (Figure 4).

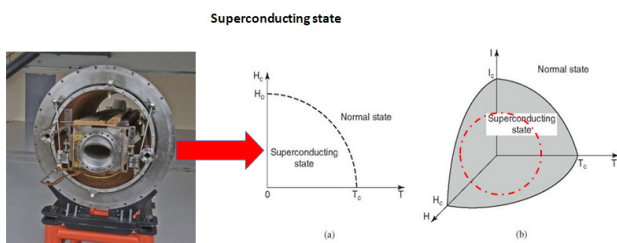

Figure 4. The region of the superconducting state of the magnet winding

The SC magnetic element of the accelerator complex

itself during the tests has the following features: heat gain due to eddy currents leading to heating of the core, heat gain from the walls and uneven cooling in the connecting nodes. These features of an individual magnetic element also impose the complexity of managing a group of similar elements.

The principle of intelligent control implies compensation for the uncertain and inaccurate parameters of a magnetic element existing in a real object through the use of soft and quantum computing technologies and taking into account the peculiarities of individual knowledge bases.

Table 1 shows the input data - indicators of the state of the system and output - parameters of the actuators controlled by an intelligent control system for the conditions of the state of nitrogen in the stand collection.

Table 1. Input and output data of MIS of nitrogen consumption

Input data	Output
Nitrogen outlet temperature data	Target valve flap position
Inlet nitrogen temperature data	Valve rotation speed
Pressure level reference signal	
Setpoint signal for nitrogen level in the collector	
Data on the state of the nitrogen level in the collector (tank)	

The efficiency of pumping, cooling the magnetic element and maintaining the superconductivity regime depends, among other things, on the pressure in the cooling system, and therefore on the nitrogen pressure in the collector and its level. In this case, it is necessary to take into account the increase and decrease in the nitrogen consumption in the process of heating and cooling the magnetic element, taking into account the inaccuracy of the actuator (valve).

Figure 5 shows the control loop of the first level, implemented in the form of a proportional-integral-differential (PID) controller with adjustable control parameters (K_p , K_i , K_d). The choice of optimal control parameters depends both on the listed features in the implementation of a separate magnetic element, and when controlling a group of magnetic elements.

Let us consider an example of designing an ICS for pressure control in a storage tank with nitrogen of a test bench of a magnet factory. At the first design stage, the indicators and parameters set by the operator in the control system were recorded (Figure 5). Further, the most effective trajectories of valve control (operator actions) were selected from the point of view of maintaining the

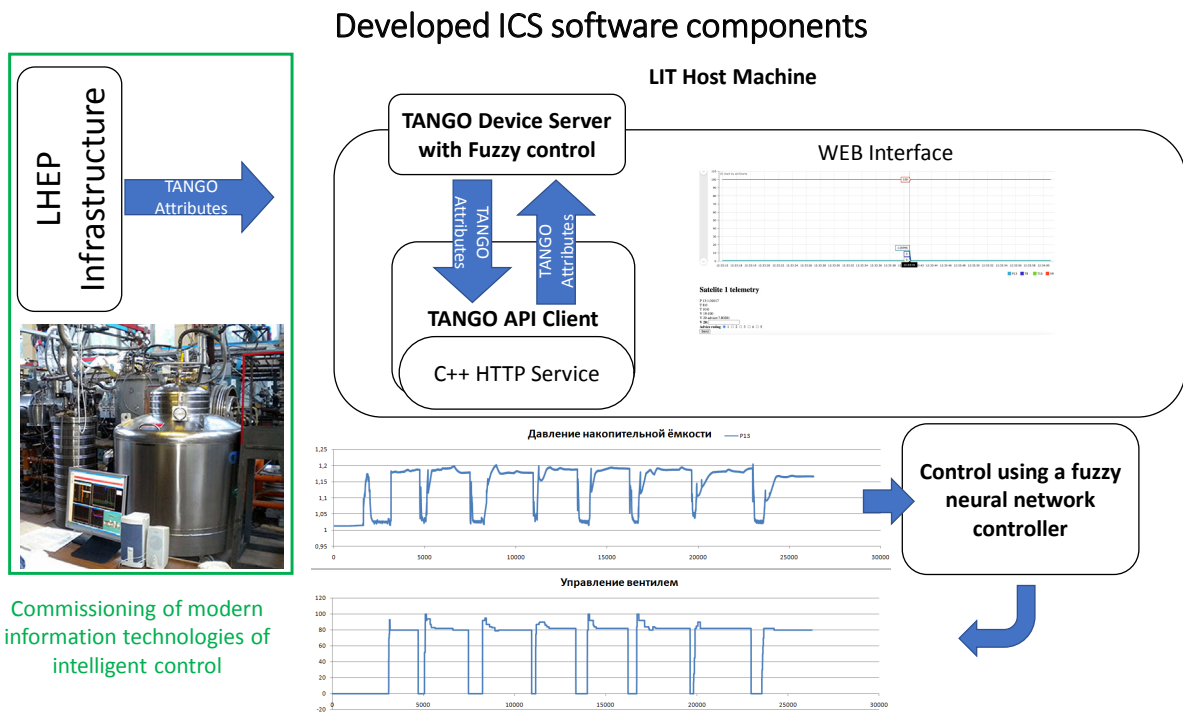

Commissioning of modern information technologies of intelligent control

Figure 5. Developed and implemented software and hardware components of the control system

Technology for designing intelligent control systems based on soft computing

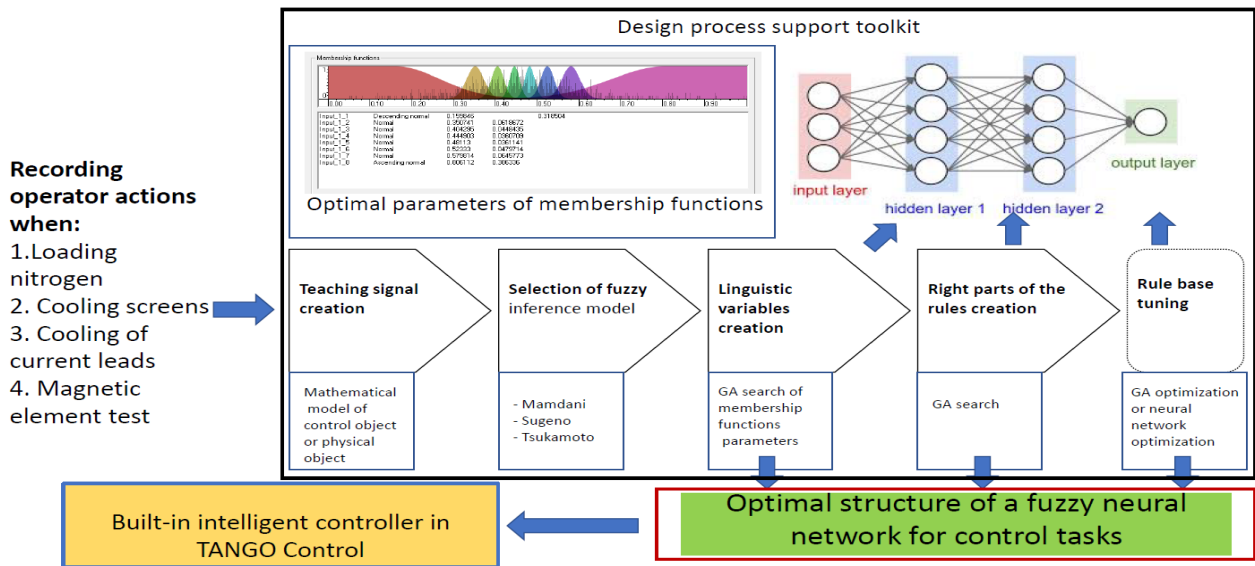

Figure 6. ICS design technology and interaction with Tango-Control

required pressure level and nitrogen flow rate.

Based on these data, using soft computing software tools from Figure 3, a fuzzy controller was designed (Figure 6).

In Figure 7 below is a graph showing operator actions (blue line) and fuzzy controller (brown line).

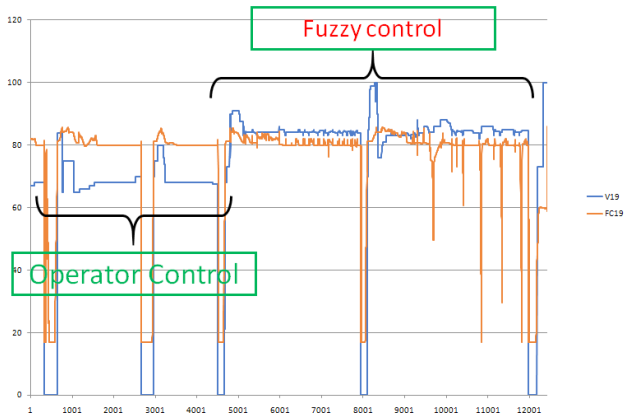

Figure 7. Control action of the operator (V19) and fuzzy controller (FC19).

In general, at this stage, the work of the regulator was assessed as correct.

In Figure 8 the experimental graphs of the nitrogen flow rate and pressure in the storage tank in the process of testing the magnetic element demonstrated, respectively.

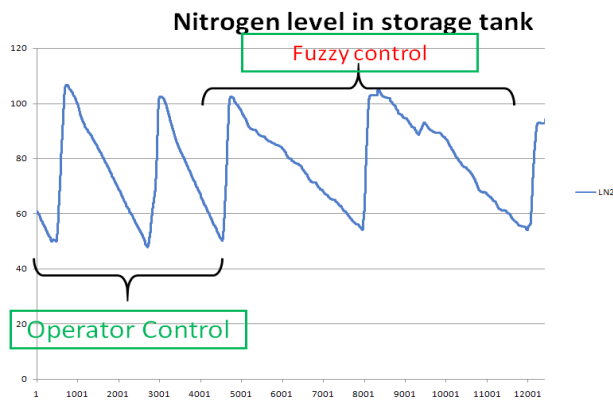

Figure 8. Nitrogen level in the storage tank

The studies carried out have shown that when regulating in the control mode of a fuzzy controller, the nitrogen flow rate decreases.

Consider the example of the process of designing an intelligent control system (ICS) of inverted pendulum, the possibility of creating an intelligent robust control system with an increased level of robustness due to the application of quantum computing technologies and various information resources in the process of extraction and formation of KB.

3. Information Technology Design of Intelligent Control System with Remote Connection to SCO & QC

Control of inverted pendulum position it's a classical task of control theory (see Figure 9). A dynamic system has global dynamic instability; in the absence of a control force, an unlimited increase in the deflection angle occurs, i.e. the pendulum falls. The task of controlling the system is to, by acting on the trolley by means of a control force, hold (stabilize) the pendulum in a vertical position (the angle of deviation of the pendulum axis from the vertical should be kept close to 0 under changing environmental conditions).

The equations for entropy production rate are as follows:

$$\dot{S}_\theta = \frac{k\dot{\theta}^2 + 1/2ml\dot{\theta}^3 \sin 2\theta}{l(m_c + m) \left[\frac{4}{3} - \frac{m \cos^2 \theta}{m_c + m} \right]}; \quad \dot{S}_z = \frac{a_1}{m_c + m} \cdot \dot{z}^2; \quad \dot{S}_u = k_d \dot{e}^2. \tag{1}$$

In Equation (1), z and θ are generalized coordinates; g is the gravity constant (9.8 m/sec^2), m is the mass of the cart, m is the inverted pendulum (called the "pole"), l is half the length of the pendulum, k and a_1 the coefficients of friction in z and θ respectively, a_2 is the elastic force of the cart, $\xi(t)$ external stochastic noise, and u is the control force.

The structure of the computer model "cart – pole" (inverted pendulum), made in the environment of modeling MatLab/Simulink, is shown in Figure 10.

This computer model is used to obtain a training signal and configure the KB using SCO. As a control model of this system, we will use the expression (1) to calculate the control effect. In accordance with this control scheme, we will use the PID controller in the global negative feedback loop.

The sequence of application of software tools, sources of training signals and the result of the stages of application of tools are presented in Figure 11. The technology of application of the quantum optimizer and quantum fuzzy inference (QFI) allows to combine into a single control system several KB obtained from various information sources, which allows to take into account both the physical features of the CO and the model representation of the system.

The model includes a PID controller, noise in the control and measurement system, as well as a unit that generates a signal for the controller.

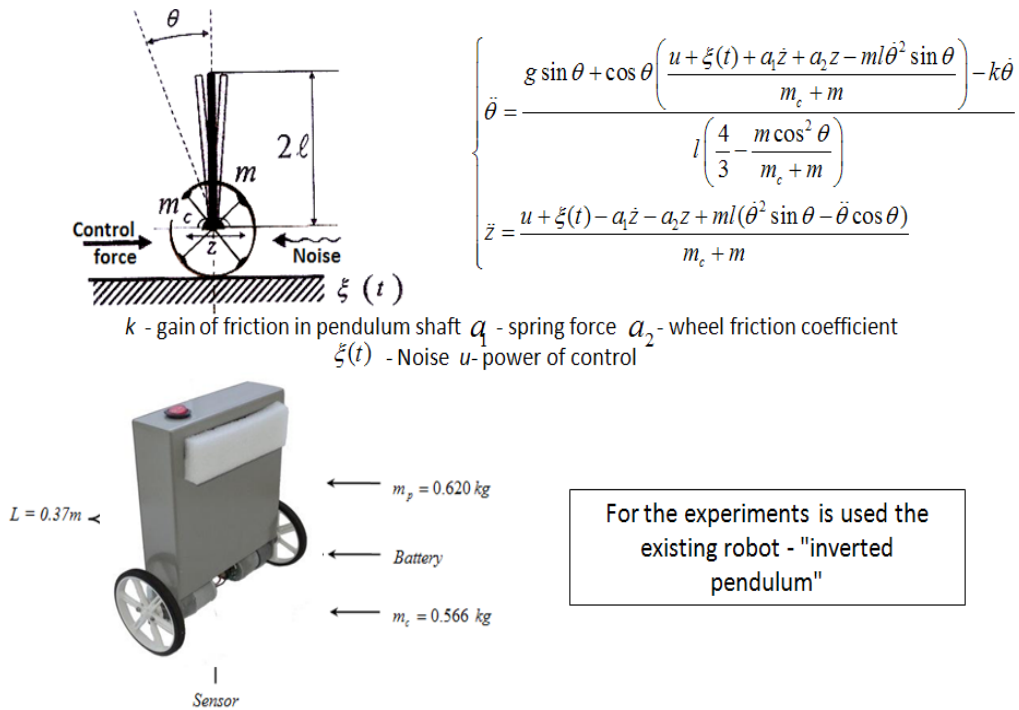

Figure 9. Intelligent control system of inverted pendulum and mobile manipulator

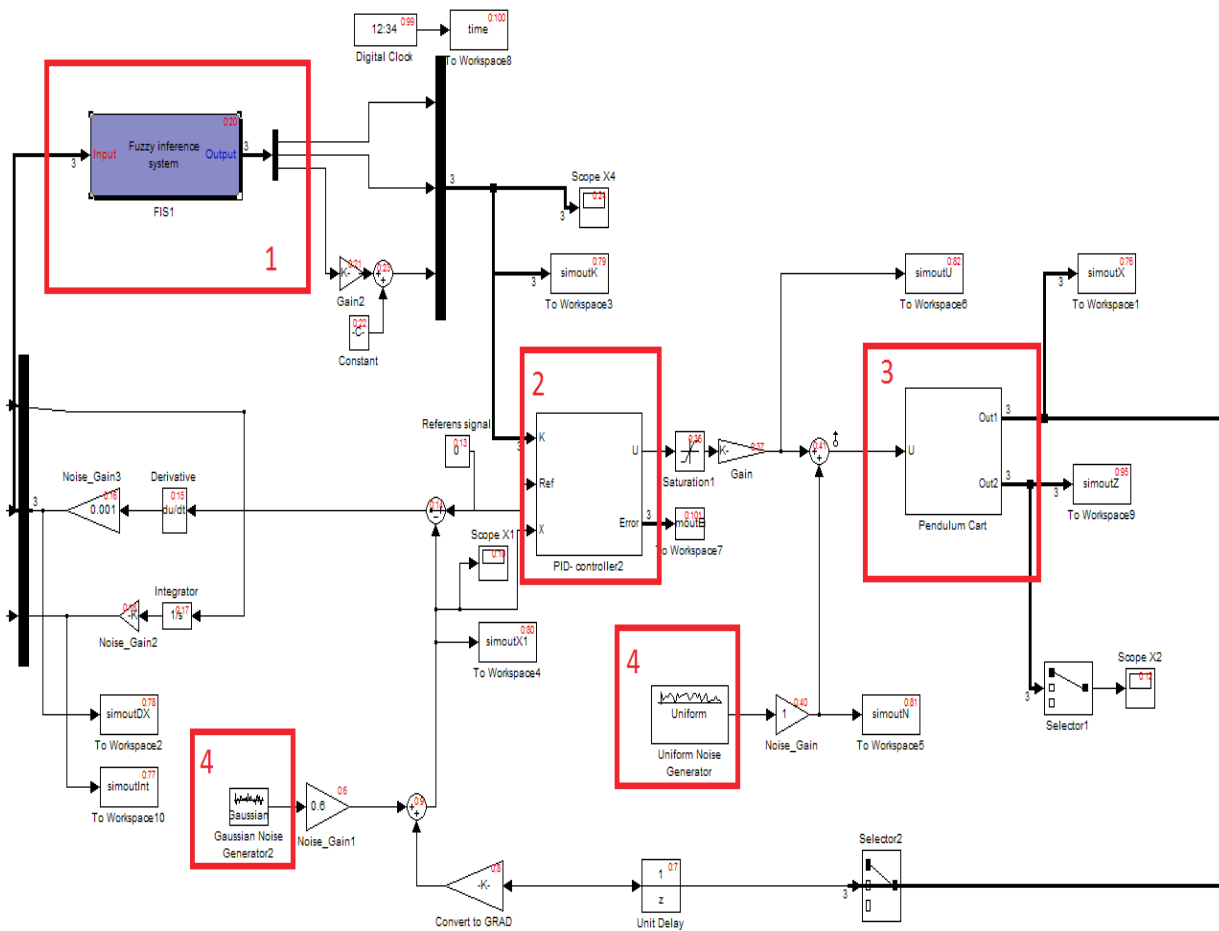

Figure 10. Modeling system structure: 1-fuzzy output unit; 2-PID controller; 3-control object; 4-noise generators

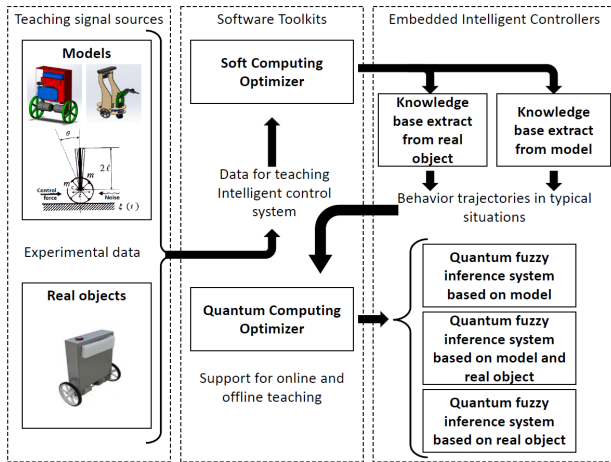

Figure 11. SCO & QO technology for designing robust ICS

The input of the SCO is a teaching signal (TS), which can be obtained either at the stage of stochastic simulation of the CO behavior (using its mathematical model), or experimentally, i.e. directly from the results of measurements of the dynamic parameters of the physical model of the CO. TS is a source of knowledge and is an array of data divided into input and output components, each of which, in turn, consists of one or more signals. If some control signal is approximated, the input components may be a control error, an error integral and its derivative, and the output component is the desired control action value, or some adjustable control system parameters, for example, the gain coefficient of the PID controller.

For Figure 12, the input data for FC is the error vector, which consists of the control error $e(t)$, the integral of the control error $ie = \int edt$, and the rate of change of the control error $\dot{e}(t)$.

e	\dot{e}	$\int_0^t edt$	k_p	k_i	k_d
-0.01	-0.01	-0.01	13.38	0.48	20.13
-0.02	-0.01	-0.04	13.38	0.48	20.13
-0.04	-0.01	-0.07	13.38	0.48	20.13
-0.05	-0.01	-0.12	13.38	0.48	20.13

0.25	-0.02	7.67	14.20	0.30	16.26
0.18	-0.07	7.84	14.20	0.30	16.26

Figure 12. Example of teaching signal.

Output data FC is a vector consisting of the values of the gain, k_p , k_d , k_i , PID controller, the values of which are used in the formation of the control action in the following form:

$$u(t) = k_p(t)e(t) + k_i(t) \int_0^t e(\tau) d\tau + k_d(t)\dot{e}(t) \quad (2)$$

Before proceeding with the design of the IC, it is necessary to verify the parameters of the mathematical model (1).

Table 2 presents the classification of defined and undefined parameters of the system model. The problem of finding undefined parameters can be solved on the basis of GA. The assumed ranges of undefined parameters are the boundaries of the search space for multi-criteria optimization. The chromosome of the algorithm consists of a vector of indeterminate parameters, and the initial population is randomly generated by the spread of chromosome's carts the search space. GA selects a set of parameters of the mathematical model so that the dynamics of the mathematical model corresponds to the dynamics of the robot (for example, the error in the form of the difference between the signals from the mathematical model and the physical signal is minimal).

Table 2. Defined and undefined parameters in the model

Certain parameter	Undefined parameters
Mass of the pendulum	Friction in the axis of rotation
Mass of the carriage	Coefficient of elasticity of the carriage
Center of gravity of the pendulum	Backlash in the axis of rotation
Limitation on the control force	Normalizing coefficient of control action
The time for one cycle of the system	The noise of the measuring system
PID coefficients	Friction of wheels on the surface
Input and output data of technical product controller	

The target function of the algorithm for verification can be based on the dispersion of information supplied to the input and received at the output of the controller or fuzzy controller.

In this case, the fitness function was used as a function of the form:

$$F(e,u) = \left\{ 1 + \left[\frac{Var(e_{mod}) - Var(e_{rob})}{Var(e_{mod})} \right]^2 + \left[\frac{Var(i_{e_{mod}}) - Var(i_{e_{rob}})}{Var(i_{e_{mod}})} \right]^2 \right\}^{-1} + \left[\frac{Var(u_{mod}) - Var(u_{rob})}{Var(u_{mod})} \right]^2 \quad (3)$$

Where $Var(e_{mod})$ – variance of control error in the model,

$Var(e_{rob})$ – variance of control error in operation, $Var(u_{mod})$ и $Var(u_{rob})$ – dispersion of the control action in the model and layout, $Var(i_{e_{mod}})$ и $Var(i_{e_{rob}})$ – variance of the integral of the control error model and layout, respectively.

It should also be noted that it is possible to use other fitness functions, for example, the integral of the difference between the points of the resulting sample graphs, etc.

After verification, the found parameters are substituted into the model, and then the coefficients for the PID controller are searched. To do this, use GA, the chromosome of which are gain, and the fitness function – the evaluation function of quality control the following:

$$f(x_r) = \frac{1}{1 + \int_0^t e^2 dt} \tag{4}$$

Where e is the value of the deviation from the master signal, t is the integration range equal to the test time of one solution. Next, the coefficients are tested on the layout according to the scheme in Figure 13.

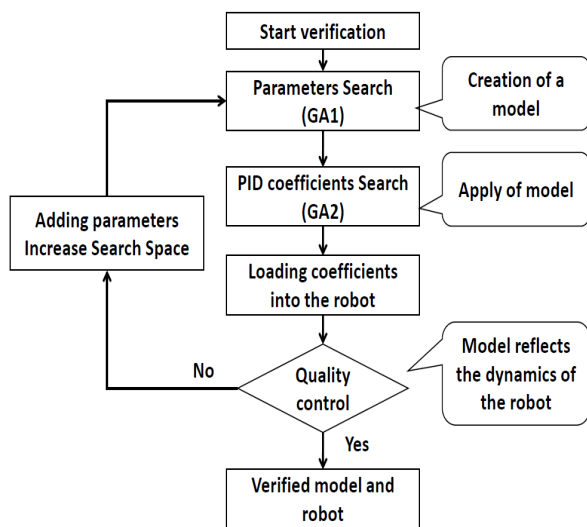

Figure 13. Algorithm verification with the use of GA

In case of unsatisfactory result, it is necessary, if possible, to re-identify the system-to reduce or increase the number of undefined parameters by fixing one or more of them in the mathematical model, with a corresponding increase in the search space parameters.

The results of verification of the mathematical model and layout of the system, in the form of graphs of control errors are presented in Figure 14.

It is required to achieve a high level of suitability of the tested solution for verification. For this case, the algorithm finished with the value of the fitness function: $Fit = 0.9847$.

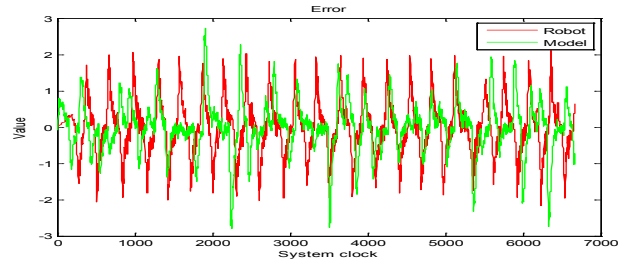

Figure 14. The angle of deviation of the robot and model

Further, on the basis of the verified model, including the selected undetermined parameters (control noise, noise intensity in the control, the coefficient of friction of the wheels on the surface, the coefficient of friction in the axis of rotation, the coefficient of elasticity, etc.) was designed KB.

4. Design Using System Layout

Consider the possibility of using GA-PID controller to obtain TS and further approximation of the signal on the neural network using SCO.

One of the disadvantages of GA is the inability to use in the future solutions that do not fall into the next generation. When documenting solutions, for a third-party observer of the algorithm, this data turns into a huge array of hard-to-process information.

For Figure 15 on the left is the TS with the layout in the form of a graph of the angle of deviation and changes in gain.

This signal is derived from the GA-PID controller. The presented data set of the learning process of the CO and the selected areas are "knowledge" about the gain and their changes. It is obvious that the information about the learning process of the robot contains knowledge (in terms of the selected quality criterion) about the suitability of the tested solutions.

It is important to note that the amount of this knowledge grows in the learning process. In the first generations (with a random distribution of chromosomes in the search space), this knowledge is minimal, but with the passage of time and the change of generations, the amount of useful information increases, and the quality of control increases. This data set contains information about both the possible States of the CO (deflection angle) and the gain for each time. Using the software tools SCO, it is possible to allocate knowledge from the signal obtained in the process of GA in on line, with their further use in the KB FC.

Thus, the designed KB will contain knowledge about the physical features of the control object, backlash, noise, friction and implementation features. This type of training allows you to extract knowledge about poorly formalized

and poorly structured CO, for which it is difficult to design an adequate model.

It should also be noted the set clock cycle time of the system. For simulation and experiment, the duration of the cycle was taken constant during the tests and is 0.01 sec.

The result of genetic selection was a signal, part of which is shown in Figure 15. This signal is the input signal in the QFI.

The first three columns in Figure 15 describe the control error, differential and integral errors, respectively, the last three coefficient gain schedule k_p, k_D, k_I .

In the second stage, the TS is fed to the SCO input, which approximates it using an user-defined fuzzy output model. The optimal representation of the linguistic variable membership functions and the number of rules is chosen.

In the second stage, the TS is fed to the SCO input, which approximates it using a user-defined fuzzy output model. The optimal representation of the membership functions of the linguistic variable is chosen. The result of the stage of construction of input linguistic variables is presented in Figure 16.

At this stage, the right parts of the rules are optimized. This uses GA₂ (for TS with layout) and Matlab modeling for TS obtained using model and layout.

The results of the KB construction are illustrated below (Figure 17).

For formation of the right parts of rules for KB which TS is received from a layout, GA 2 was used. The fitness function at this stage is the minimum of the TS approximation error. The result of creation and optimization of KB rules is presented in the form of a neural network in Figure 17. The first layer shows the number of input variables, the second-the number of membership functions for each variable, the third - the production rules of KB, the fourth - the values of the gain.

Figure 18 shows the relationship between the training signal obtained using a mathematical model and the gain of the fuzzy controller.

The regulators were designed to function in a typical control situation. To compare the robustness of the developed control systems, we use an unexpected control situation. The situation is modeled by the presence of noise in the coefficient of friction of the wheel on the surface and in the control action. As such noise in the experiment a special coating is used, and the corresponding parameter values were set for the models.

Consider the behavior of PID and fuzzy controllers in a typical and unexpected control situation. In Figure 19-22 the results of modeling and experiments in a typical control situation are presented.

Table 3 presents a comparison of the KB by the number of rules, the number of functions belonging to the linguistic variable and the method of optimization in the software tools of the KB.

Table 3. Comparison of KB

Knowledge	Number of rules	Number of fuzzy sets	Optimization method
Knowledge base from model 1	245	8x6x6	simulation
Knowledge base from model 2	276	8x9x6	simulation
Knowledge base from robot 1	288	9x9x6	Approximation of TS
Knowledge base from robot 1	270	5x8x8	Approximation of TS

Research of quality of control of the PID-regulator and fuzzy regulators on the basis of software tools of SCO was carried out with use of mathematical model and real CO. The regulators were designed to function in a typical control situation. The parameters of the mathematical model used for modeling are presented in Table 4.

Table 4. Control situations, parameters of mathematical models

	Typical situation (C1)	Unforeseen situation (C2)
Initial angle	0rp	0rp
Initial velocity	1rp/c	1rp/c
Weight of the cart	0.56 kr	0.56 kr
Mass of the pendulum	0.63 kr	0.63kr
Length of the pendulum	0.07 m	0.07 m
Friction in fastening	2.75 + normalized noise with intensity 0.01 and an amplitude of 0.35	3.55 + normalized noise with intensity 0.01 and an amplitude of 0.35
Friction of the wheels	3.63 + Gaussian noise 15%	2.53 + Gaussian noise 15%
Elastic force	5.54H/m	7.54H/m
Noise in the control system	Uniform [-2.15 2.15], the intensity of 0.48	Uniform [-2.15 2.15], the intensity of 0.48
Noise in the measurement system	Gaussian noise, amplitude 0.22, intensity 0.01	Gaussian noise, amplitude 0.42, intensity 0.01
Delay on feedback control loop	0.01 c	0.01 c

To compare the robustness of the developed control systems, we use an unexpected control situation. The situation is modeled by the presence of noise in the coefficient of friction of the wheel on the surface and in the control action. As such noise in the experiment a special coating is used, and the corresponding parameter values were set for the models.

In Figure 10 the structure of the modeling system is presented. Consider the behavior of PIDs and fuzzy con-

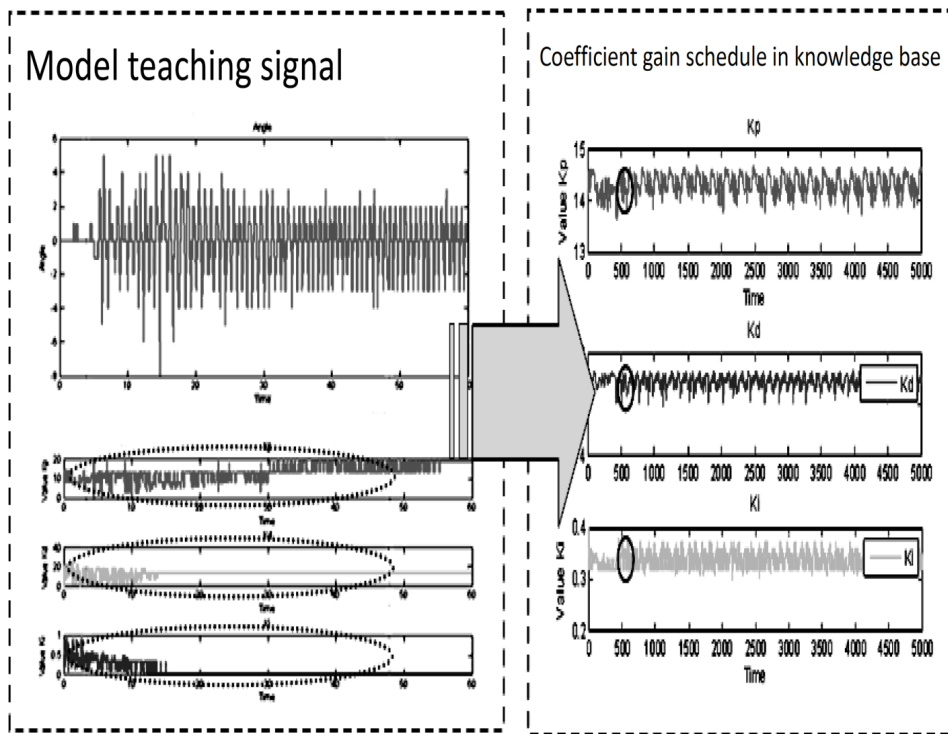

Figure 15. On the left TS from the layout (GA-PID controller), the right gain FC.

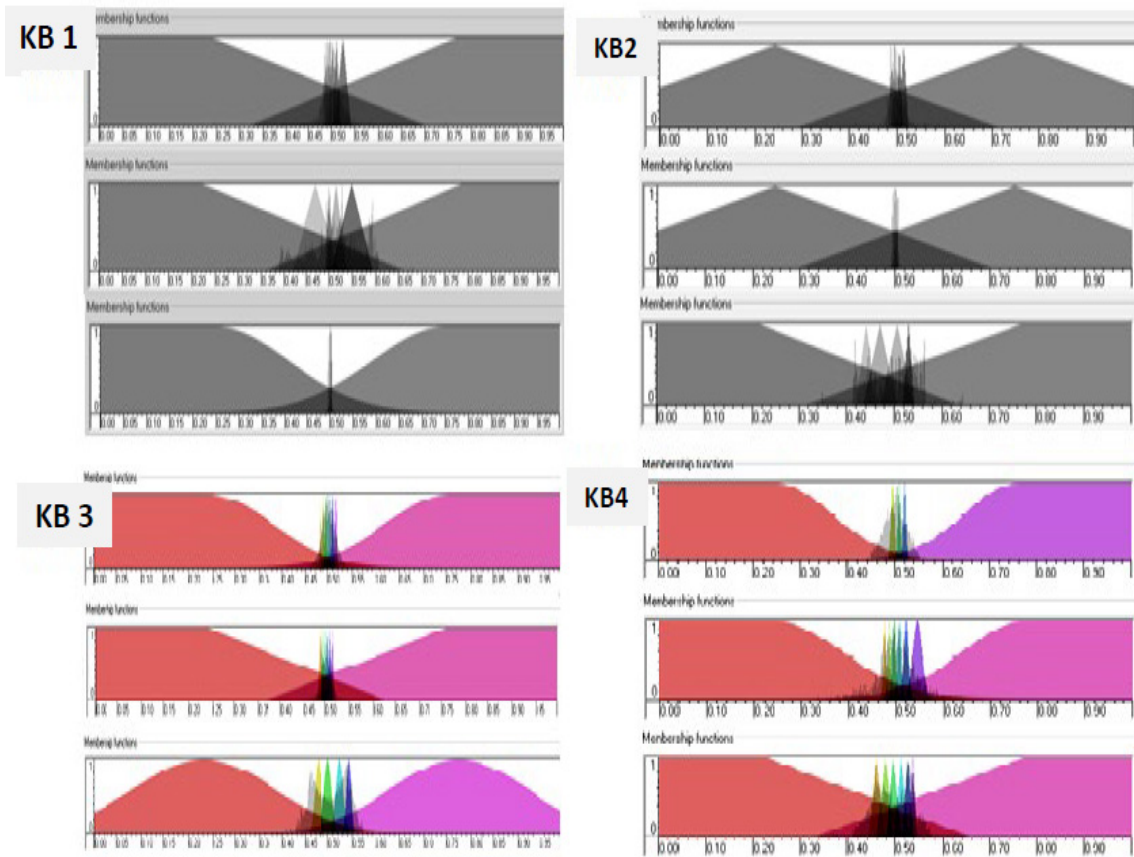

Figure 16. Membership functions for input values of linguistic variables BS1, BS2, BS3, BS4.

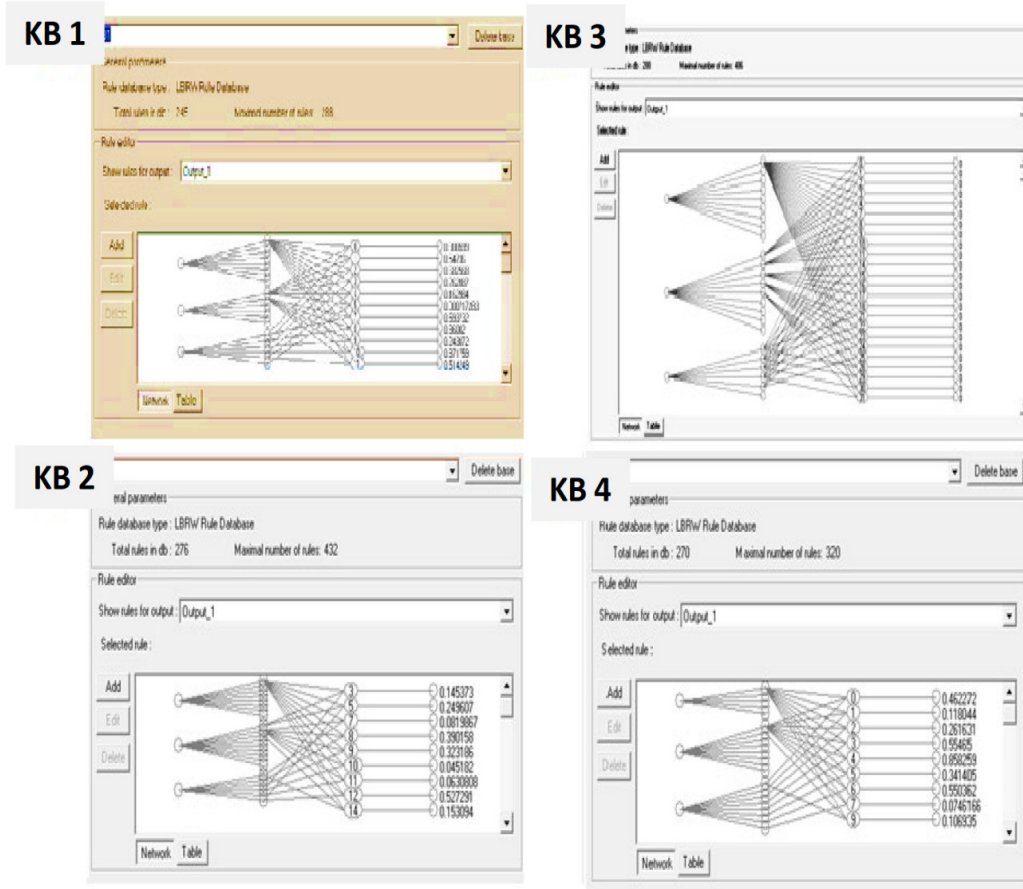

Figure 17. Knowledge bases in the form of neural networks (TS with model and layout)

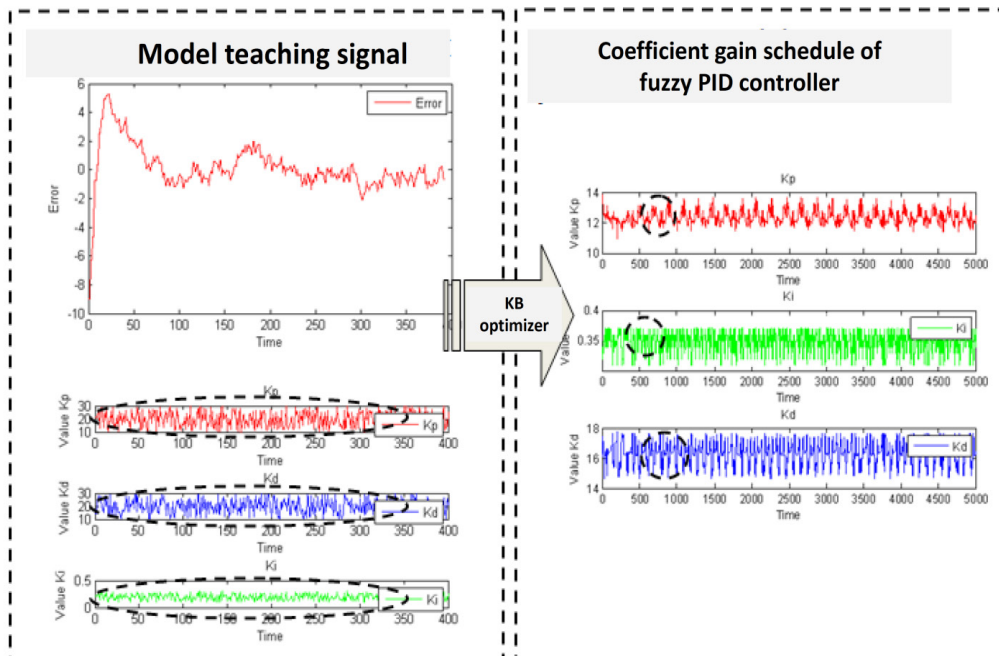

Figure 18. TS from models and FC output gains.

trollers in a typical and unexpected control situation. In Figure 19-22 the results of modeling and experiments in a typical control situation are presented.

We will analyze the quality of control of FC and PID regulators. To do this, we use the following indicators of

the transition process (Figure 23):

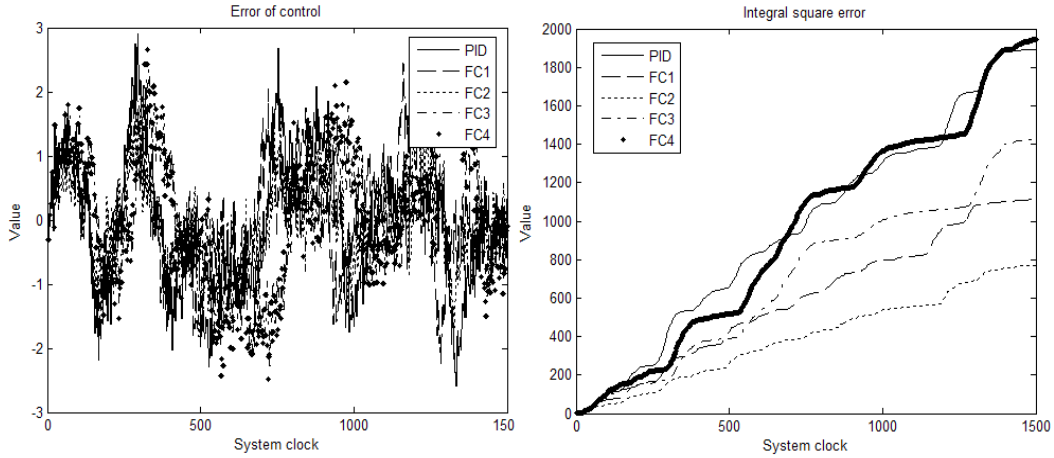

Figure 19. Left error control, on the right the integral square error. Typical control situation. Modeling

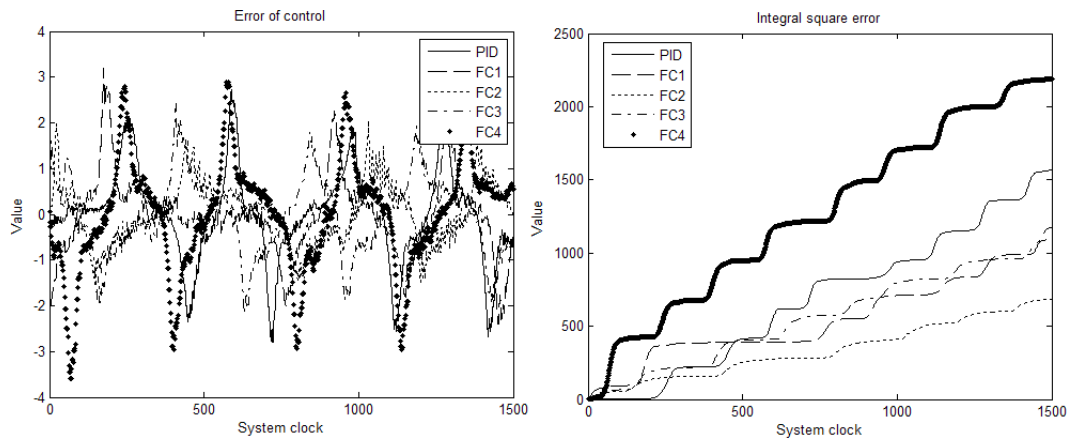

Figure 20. Left error control, on the right the integral square error. Typical control situation. Experiment

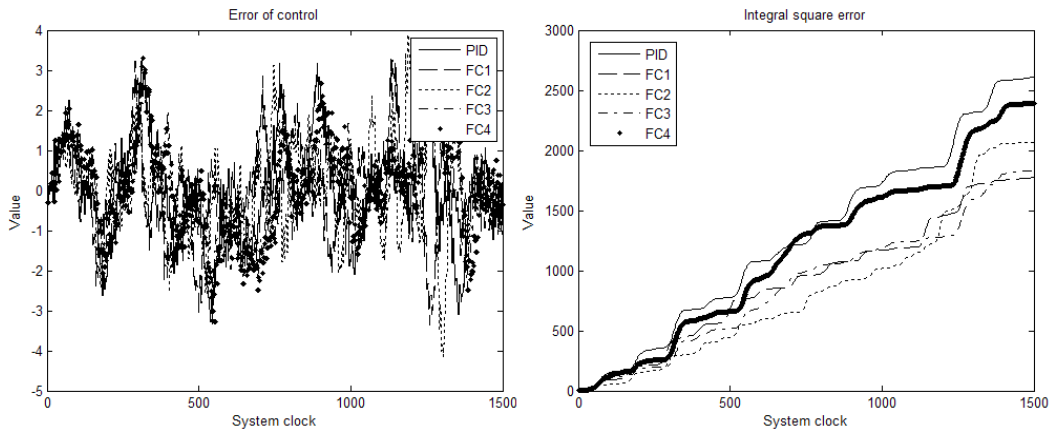

Figure 21. Left error control, on the right the integral square error. Unforeseen control situation. Modeling

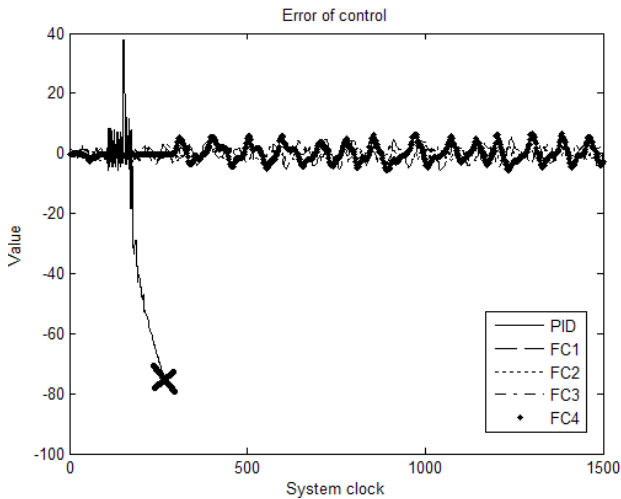

Figure 22. Control error. Unforeseen control situation. Experiment

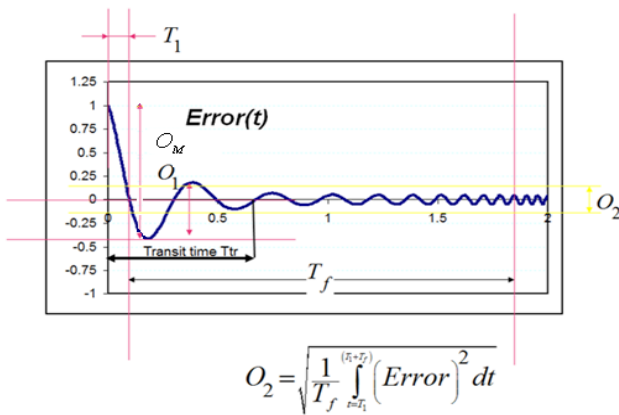

Figure 23. Control quality indicators.

Overshoot characterizes the oscillatory property of the transition process and is calculated according to the following expression:

$$O_1 = 1 - \frac{O_m}{O_1}; O_m(const) \geq O_1; \tag{5}$$

Figure 24 shows a diagram of the level of over-regulation of control systems. A fuzzy controller developed on the basis of a verified mathematical model has a lower overshoot rate, which characterizes the operation of such a controller as more efficient.

Stability of transition process of regulators (Figure 25) is calculated as:

$$O_2 = 1 - \frac{O_2}{O_m}; O_m(const.) \geq O_2; \tag{6}$$

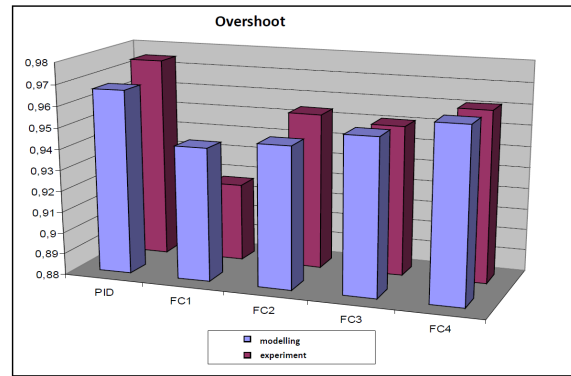

Figure 24. Over-regulation of control systems in a typical situation. Simulation and experiment

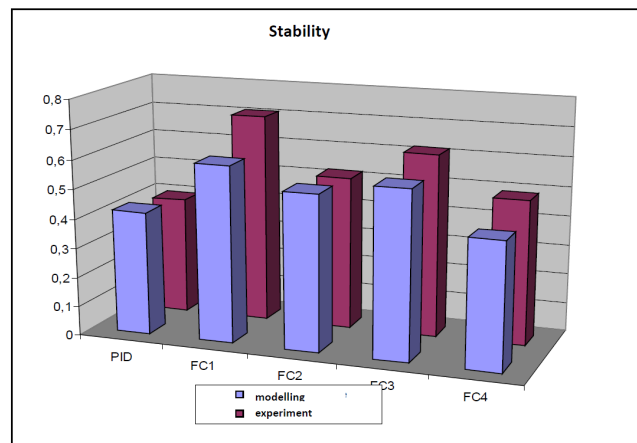

Figure 25. Stability of control systems in a typical situation. Simulation and experiment

The quality of control characterizes the ability of the control system to effectively consume the energy and technical resource of the system. In the case of complex control, equipment wears and energy costs will be high.

The complexity of ICS control (Figure 26) is calculated in the form:

$$P \equiv 1 - \left(\frac{\sqrt{\frac{1}{T} \int_{t=0}^T \left(\frac{dK}{dt} \right)^2 dt}}{A} \right); A = (const) \tag{7}$$

The evaluation of the complexity of the control showed that fuzzy controllers developed using SCO provide the system with simpler control, which ultimately has a positive effect on the life of the equipment, reducing wear and increasing reliability.

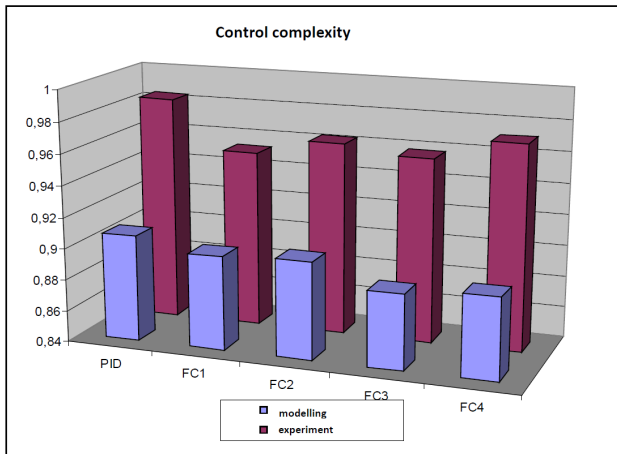

Figure 26. Complexity of control in a typical situation. Simulation and experiment

The results of the simulation and experiment in an unexpected situation are presented graphically in Figure 21-22. From the graphs (Figure 19-22) it can be seen that the PID controller does not have the necessary robustness, which in an unforeseen control situation leads to a loss of stability of the system.

Thus, the result of using the tools at the first stage of the ICS design process is the required type of universal approximator in the form of FC with an optimal KB structure (see, Figure 1, Step 1).

The technologies for remote configuration and transmission of knowledge bases allow the control object (CO) to accept the KB from the SCO block, or from other CO, which makes it possible to control structurally new objects such as robot teams, multi-agent systems, complex automated production facilities, etc. In addition, this technology allows the CO to update and adapt the KB for a specific control situation, including an abnormal situation.

5. Technology of Remote-control Object Setting

Remote control setting allows to adapt fuzzy control system to a specific (unexpected) control situation regardless of the time and location of the CO. This kind of self-organizing ICS with remote design of KB is important for elimination of consequences of accidents at the nuclear power plant, at analysis of blockages at earthquakes, train crash, for work in the polluted and radioactive environment, etc.

Let's consider the remote connection module of the SCO and the real CO for setting up the KB. A USB connection or a Bluetooth radio channel are used for data transfer. The information is shared between the control system and the SCO to form a KB (Figure 27).

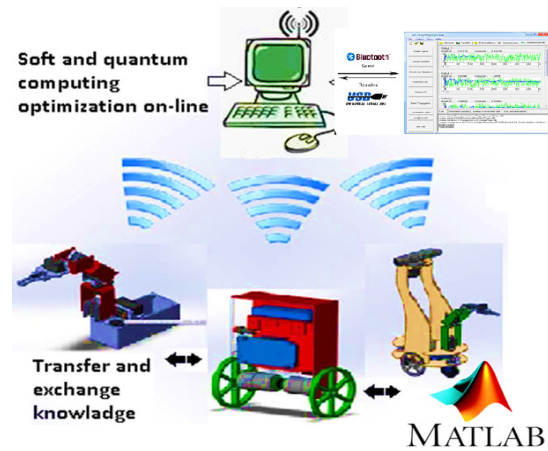

Figure 27. Connection diagram of a configurable device and knowledge base optimizer

Remote KB optimization is carried out at the fourth stage of FC design. The implementation of the physical connection environment involves the use of additional equipment for receiving and transmitting data, for example, a Bluetooth radio channel, WiFi or cable connection, for example, USB.

It is assumed that the exchange of information between the control system and the SCO for the formation of KB (Figure 27). The detailed process of setting up the functioning of such a system is presented in (Figure 28).

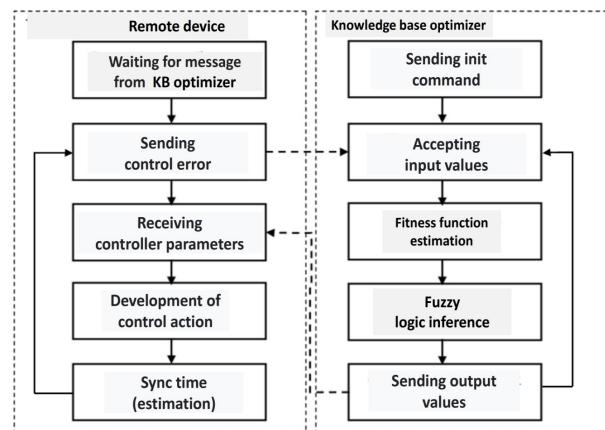

Figure 28. The algorithm works remote configuration

The control system gets the readings from the sensors and sends them to the computer for further processing. By assuming input values, SCO evaluates the previous solution (KB FC) in the GA function and makes a fuzzy conclusion for verifying the next solution (KB FC). The result of the fuzzy conclusion is sent to the remote device. After that, the control system, having processed the input values, generates a control action. Thus, the configuration of the KB FC is realized on line. The connection profile

uses the serial port. The transmission speed in this case is 115200 bps. In the process of functioning, numbers are transmitted through the COM-port in the symbolic form. Connection to the SCO is carried out through the developed plug-in (Figure 29).

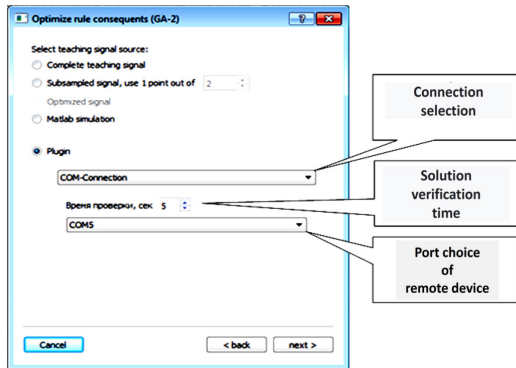

Figure 29. Remote configuration module for REVIEW

The remote KB transmission is the next step in the development of the wireless connection of the CO with the SCO. In this case, it is not control actions that are transferred from the SCO, but the KBs, that is, information and knowledge of a higher level is shared. The implementation of the connection environment involves the use of the IEEE 802.11 (Wi-Fi) standard and the TCP / IP protocol for data reception-transmission. Information is shared between the control system and the SCO to form and transfer KB. Structurally, from the point of view of the software engineering, the KB is implemented by a structural type of data and its size depends on the number of input and output variables, the number of membership functions of the linguistic variables and the number of production rules. At the speed of 1 Mbit / s, the transmission of a 10 KB with internal delays takes no more than 100 ms, which allows to qualitatively rebuild the ICS for a given task in the on-line mode.

As a data transmission medium consider the possibility to use the radio module presented in Figure 30 to wirelessly tune the KB of a dynamically unstable object.

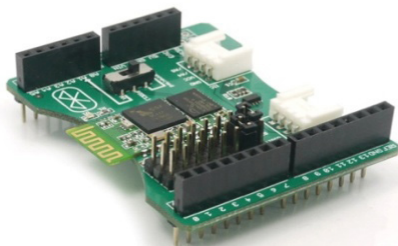

Figure 30. Bluetooth radio module.

Let's set the maximum time delay limit for receiving and transmitting data in a communication environment. The time delay is 40 MS, which is critical for typical control systems discussed earlier. Based on this, the control situation with such a delay value can be considered extreme.

To solve the control problem, we change the law of formation of the control action (1). The reference signal of the stabilization system will depend on the integral error (8), this will allow the system to function at a critical time delay:

$$ref = -a \cdot \int edt, \tag{8}$$

where *a* is an experimentally matched parameter equal to 0.25. In expression (8), the angle of the reference signal depends on the accumulated integral error. It is important to note that in addition to the value of the setting signal was imposed restriction, and its value should not go beyond the aisles of the range[-16,16].

The result of the TS approximation is the constructed KB for FC, including an optimal finite set of rules and optimally generated parameters of the membership function of the input and output variables of the FC. Thus, the result of designing is a required type of the universal approximator in the form of FC with an optimal structure of the KB.

Let's compare the PID controller (PID) with the FC (FC1), optimized with the help of the remote setting to control object. Figure 31 (a) represents the angle of deviation of the controllers being compared, and Figure 31 (b) shows an integral estimation of the deviation angle in a typical situation. Figure 32 (a) shows the level of the left and right wheel departure from the launch point, and Figure 32 (b) represents an integral assessment of departure.

Figures 31 and 32 show that the FC error level is below the PID controller, both in terms of the deviation angle and the departure from the launch point.

Practice and simulation results have shown that in conditions of uncertainty or inaccuracy of initial information, unforeseen situations or information risk, the traditional (using the principle of global negative feedback) and widely used in the industry PID regulator often fails to cope with the task of control. At the same time, the solution of the problem of global robustness of the PID controller is still unknown, despite the relevance of this problem.

The use of fuzzy controllers (FC) in conjunction with the PID controller led to the creation of hybrid fuzzy Issus with different levels of intelligence depending on the completeness and correctness of the designed knowledge base

(KB). The use of soft computing technology (based on genetic algorithms and fuzzy neural networks) has expanded the effective application of FC by adding new functions in the form of learning and adaptation. However, in the General case of abnormal control situations, it is very difficult to design a globally "good" and robust ICS structure. This limitation is especially typical for unforeseen control situations when the CO operates in sharply changing conditions (sensor failure or noise in the measuring system, the presence of a delay time of control or measurement signals, a sharp change in the structure of the CO or its parameters, etc.). The solution of such problems can be found on the basis of the introduction of the principle of self-organization of KB in the design process of FC, which is implemented and programmatically supported by the developed model of QFI using the methodology of quantum soft computing and system engineering-System of System Engineering (synergetic principle of self-organization) [20].

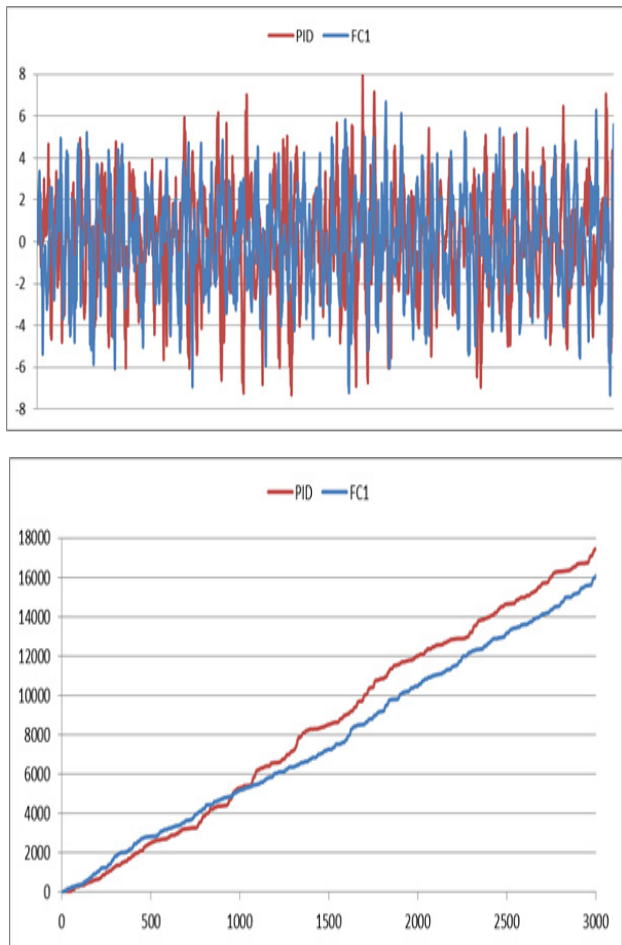

Figure 31. The deviation angle of an inverted pendulum (a), the integral estimation of the deviation angle (b)

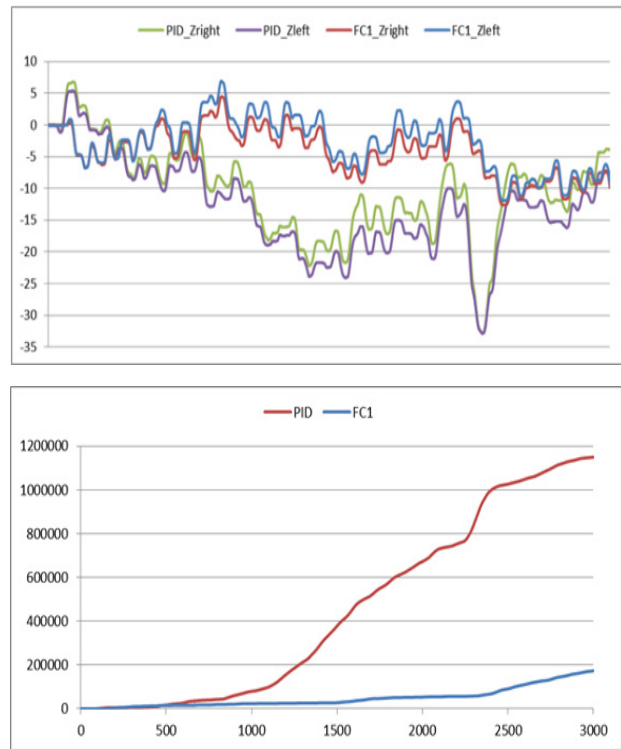

Figure 32. The departure of the right and left wheels from a start point (a), integrated assessment of departure from the start point

The proposed model uses private QFI individual KB FC, each of which is obtained with the help of the knowledge base optimizer (SCO) for the corresponding conditions of operation of the OC and fixed control situations in an external random environment. The process of designing private individual KB FC using software tools SCO for given control situations is carried out in accordance with the design technology and is discussed in detail in [23].

6. Structure and Basic Functions of Quantum Fuzzy Inference

The purpose of applying quantum computing and creating a self-organizing quantum controller is to combine the intelligent controllers of various sensors obtained in the first stage into a self-organizing connected multi-agent network based on a quantum controller and cognitive-informational interaction between knowledge (KB) (Figure 1, Step 2). Structural implementation of the process of self-organization in the QFI model [19] presented in Figure 33.

The basic idea is to find the possibility to use the classical states of various regulators (sliding, fuzzy, classical) for achieving goal of control in unforeseen situation. Quantum fuzzy inference (QFI) technology ensures the required level of robustness, without changing the lower

level of control, only through the use of software level.

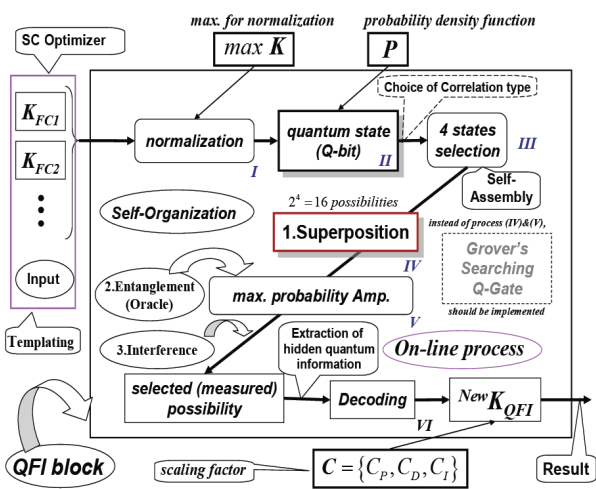

Figure 33. Structural implementation of the process of self-organization in the QFI model:

In this case, the robustness property (by its physical nature) is an integral part of self-organization, and the required level of robustness of the ICS is achieved by fulfilling the principle of minimum production of generalized entropy noted above. The principle of minimum entropy production in the CO and control system serves as the physical principle of optimal functioning with a minimum consumption of useful work and is the basis for the development of a robust ICS.

Reliable functioning of natural self-organizing systems is provided by using their individual properties, a combination of these approaches and algorithmic formation of a complex of properties in changing or unforeseen conditions. The process of designing robust KB corresponds to the abovementioned process of optimal support of the introduced thermodynamic relationship between the noted fundamental qualities of control (thermodynamics control quality trade-off, obtained as a physical criterion of self-organization).

Let us emphasize that the effect of self-organization of KB in the ICS is based on the virtual process of extracting additional (hidden) quantum information from the reaction (to an unforeseen situation) of classical control signals at the output of KB, designed in the learning environment, and is physically implemented^[2,20] by software tools based on QFI.

In Figure 34 (as the realization of the structure in Figure 33) the functional structure of the simplified QFI model is shown.

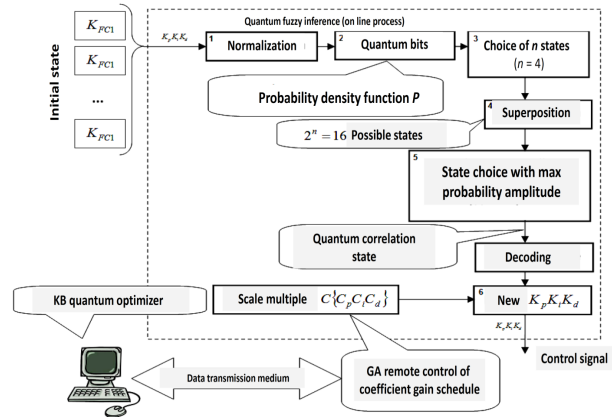

Figure 34. The functional structure of a QFI in real time

The following steps are implemented in the SC model for QFI:

- 1) the fuzzy output results of each independent individual FC are processed;
- 2) choose the type of quantum correlation;
- 3) a superposition is formed for the selected quantum correlation;
- 4) the valuable quantum information hidden in independent individual KB is extracted (on the principle of minimum entropy in the extracted quantum knowledge – maximum amplitude of probabilities of "intelligent state") on the basis of methods of the quantum theory of information;
- 5) in real time, a generalized output robust control signal is projected on a set of KB in the form of FC reactions to a new control error.

QFI was realized with the help of software tools – quantum optimizer (QSCOptKBTM). QFI itself is a new quantum search algorithm that realizes the search in dissimilar spaces of solutions embedded in KB. QFI, as a special case of the quantum algorithm, includes superposition and quantum oracle operators. In addition, which makes the algorithm unique, are used quantum correlations matrix as a source of additional information latent in classical information states, (tensor multiplication with the extraction of additional hidden information embedded in classical signal states).

In this case, the output signal of the QFI in real time represents the optimal control signal for changing the gain coefficients of the fuzzy PID controller in the ICS of a specific robot control task. The signal includes the necessary (best) quality characteristics of the control output signals of each FC, thus realizing the principle of self-organization. Qualitative features of the synergistic effect of self-organization are taken into account in the selected type and type of quantum correlation.

At the physical level of interaction of robotic systems, the effect of self-organization introduced in accordance with the information-thermodynamic criteria, provides the system with a minimum loss of useful resource even in unforeseen control situations, such as the delay of the control action. At the same time, the minimum of initial information about the system, without destroying the lower executive level of the system control and without adding additional sensors, allows for the solution of new control problems manifested in the interaction of groups of robots.

Consider the possibilities of the organization Synergetic Effects of Information-Cognitive Interaction in Intelligent Socio-Cyber-Physical Robotic Systems with Remote Knowledge Exchange and for starters Using the classic control theory problem as an “cart – pole system (inverted pendulum)” as an example, consider the design process of an intelligent robust control system using soft and quantum computing.

The main task solved by the QFI is the formation of KB with an increased level of robustness from a finite set of KB for FC, formed with the use of soft computing technology. Let us briefly consider the functional structure and operation of the main blocks of QFI. As an example, without losing the generality of the result, we will discuss the processes of extraction of hidden quantum information, data processing and the formation of robust KB FC, using the KB of two FC, designed for fixed (different from each other) control situations.

Using a standard decoding procedure (the internal product of vectors in Hilbert space) and selecting scaling coefficients for the output values of the projected gain (Figure 34, block 6), the iterative work of the SC QFI is carried out. The possibility of remote connection of the CO to a stationary computer system opens the possibility of remote configuration, formation and self-organization of BP FC in on line.

7. Quantum Computing on a Classical Processor: Application in Robust Control of an Unstable CO

Designing a control system based on QFI is carried out using the developed software tools "Quantum optimizer"^[19]. The technology of application of QFI allows to unite in uniform control system of several KB, and thus, allowing fuzzy neural networks to work in parallel (Figure 35).

Let us consider the possibility of using QFI to combine the KB obtained on the basis of a training signal from a physical object (GA-PID controller) and a verified mathematical model (Figure 36). Before proceeding to the cre-

ation of quantum FC, it is necessary to obtain histograms of the distribution of the output signals (gain) of fuzzy controllers (Figure 36).

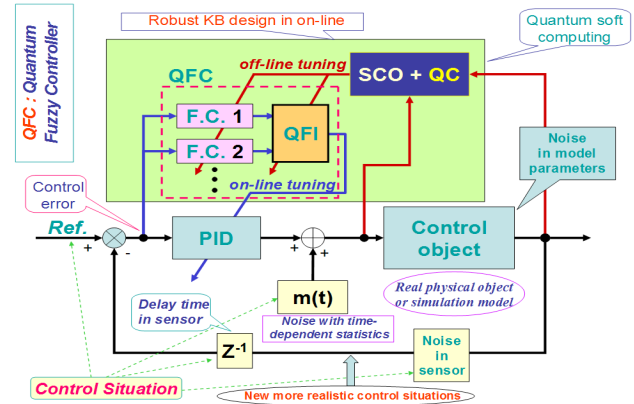

Figure 35. Intelligent control system of inverted pendulum, manipulator and mobile platform with QFI

To do this, a series of experiments and simulations are carried out, in a typical control situation. Using the obtained values of the gain coefficients in the model and layout, an array of data is formed to construct histograms of the gain coefficients of the PID regulators (Figure 36).

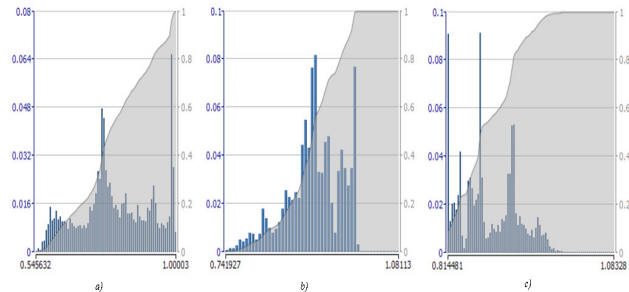

Figure 36. Histograms of output values of fuzzy controllers

Histograms are built automatically when data is loaded into the quantum optimizer. In the future, they are used in the QFI algorithm for the formation of virtual States. Gain histograms obtained experimentally are used in the formation of QFI for the robot (in a physical experiment), gain histograms obtained using a mathematical model are used in the formation of QFI for modeling. After loading the data, the type of quantum correlation between the gain factors is selected. The formation of entangled States is carried out on the basis of the selected correlation matrix, which is set in the working window of the optimizer.

In the next step, the corresponding maximum and minimum values for the input and output signals of the QFI are set and the scaling coefficients are adjusted (block 6, Figure 34). It is assumed to use a mathematical model or remote connection to the control object, that is, additional

equipment for receiving and transmitting data, for example, a Bluetooth radio channel, WiFi or cable connection, for example, USB. The exchange of information between the CO and the quantum optimizer (QO) is assumed to search for scaling coefficients (block 6, Figure 34) the quantum of the regulator. As a result of the design, the output signal from the QFI unit is used to control the gain of the PID controller in the case of modeling a mathematical model, and for a robot in a physical experiment, an exported file with the extension "*" is used. after.»

8. The Results of Simulation and Experiment in Unforeseen Control Situation

We consider the application of the developed model of QFI for the formation of control processes of gain fuzzy PID controller. To do this, we will conduct a computer simulation for two control situations:

- in the first (typical) situation (C1) the delay of the control signal is standard-0.01 sec;
- in the second Unforeseen (C 2), the control signal delay is 0.04 sec (quadrupled).

Table 5 presents the parameters of the mathematical model for C1 and C2.

Table 5. Control situations and parameters of mathematical models

	Typical situation (C1)	Unforeseen situation (C2)
Initial angle	0dg	0dg
Initial velocity	1dg/c	1dg/c
Weight of the cart	0.56 kg	0.56 kg
Mass of the pendulum	0.63 kg	0.63 kg
Length of the pendulum	0.05 m	0.07 m
Friction in fastening	3.55 + normalized noise with intensity 0.01 and amplitude 0.35	3.73 + normalized noise with intensity 0.01 and amplitude 0.35
Friction of the wheels	3.63 + Gaussian noise, Amplitude 15%	3.63 + Gaussian noise, Amplitude 15%
Elastic force	5.54H/M	5.54H/M
Noise in the control system	Uniform noise [-2.15 2.15], intensity 0.48	Uniform noise [-2.15 2.15], intensity 0.48
Noise in the measurement system	Gaussian noise, Amplitude 0.22, intensity 0.01	Gaussian noise, Amplitude 0.32, intensity 0.01
Delay on feedback control loop	0.01 c	0.04 c

In Figure 37 the structure of the modeling system is presented:

The results of modeling regulators in a typical control situation are illustrated in Figures 38 and 39.

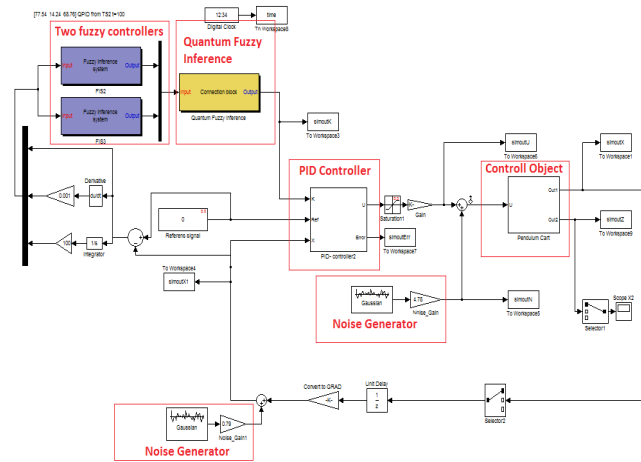

Figure 37. The structure of the modeling system in Mat-Lab/Simulink. The diagram shows: two fuzzy controllers; QFI block; PID controller; control object; noise generators

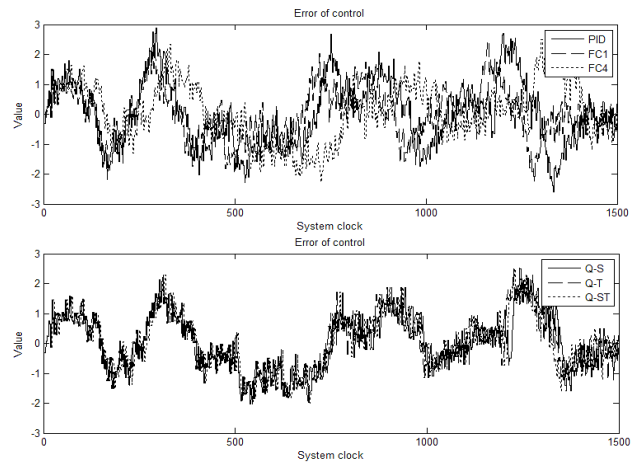

Figure 38. The angle of deviation of the mathematical model. Typical control situation (C 1). Modeling

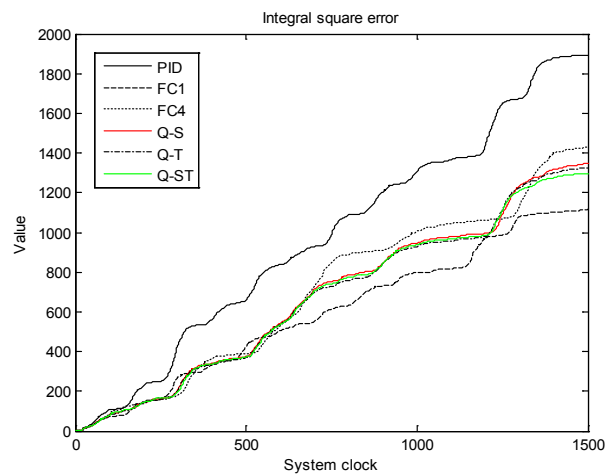

Figure 39. Integral of square error. Typical control situation (C 1). Modeling

Consider the relationship between input and output QFI values on the example of proportional gain. Figure 40 presents the input values of QFI and the output value of the proportional coefficient of QFI spatial correlation.

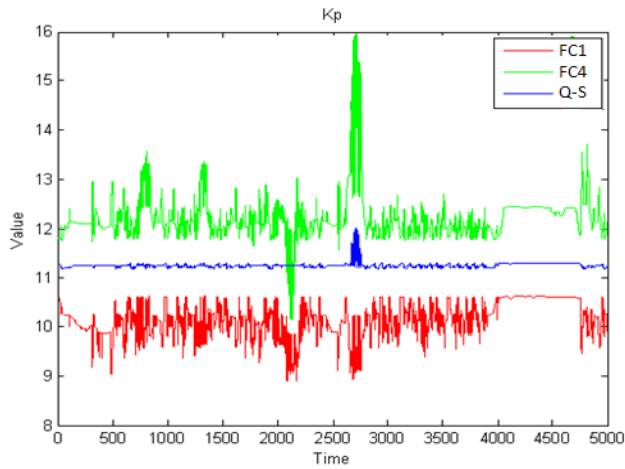

Figure 40. The gain K_p . The input and output values of QFI. Modeling in a typical control situation

In Figure 41 results of the angle of deviation (the case of the mathematical model) in unforeseen control situation demonstrated.

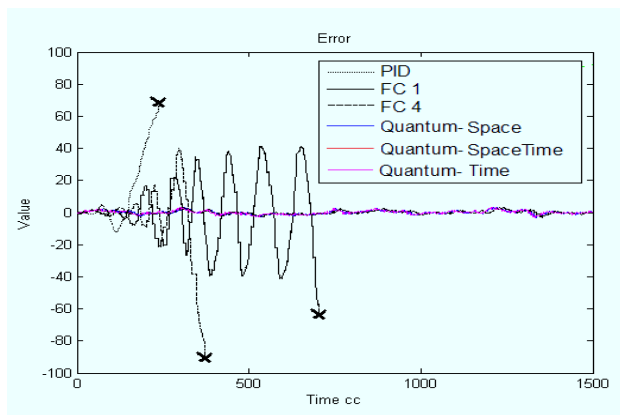

Figure 41. The angle of deviation of the mathematical model. Unforeseen control situation. Modeling

In Figure 42 the general diagram of the integral of square error of modeling is presented.

Note that in Figure 42 the value of the integral error of the quantum fuzzy controller is located between the corresponding graphs of the controllers that formed the QFI.

Consider the results of the experiment in a typical control situation. For Figs 43-45 the results of experiments in a typical control situation are presented.

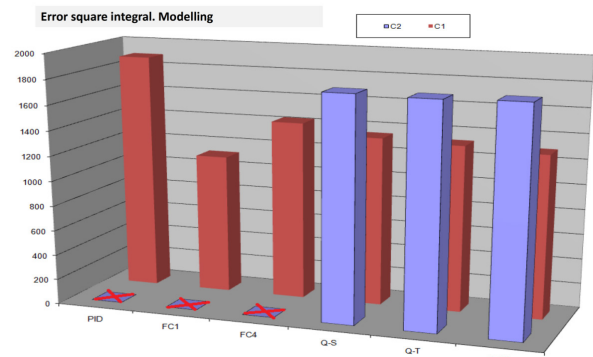

Figure 42. Integral of square error. Unforeseen and typical control situations. Modeling. FC1-FC4-fuzzy regulators, abbreviations Q-quantum, S (Space) - spatial, T (Time) – temporal, ST(Space-Time) – spatial-temporal correlations

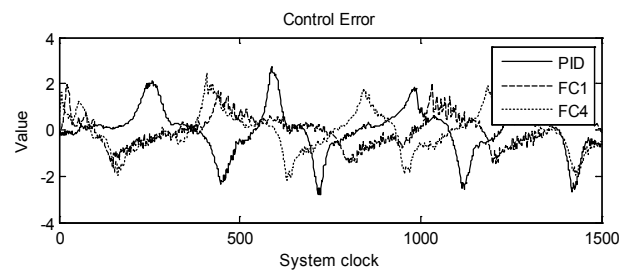

Figure 43. The angle of deviation of the layout. Typical control situation. Experiment

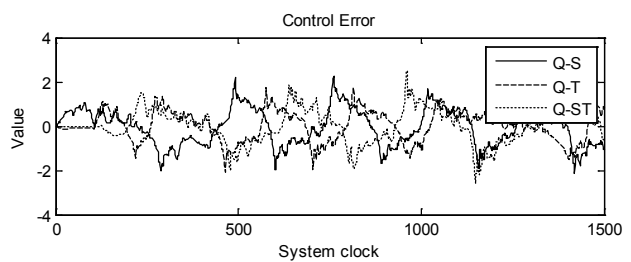

Figure 44. The angle of deviation of the layout. Typical control situation. Experiment

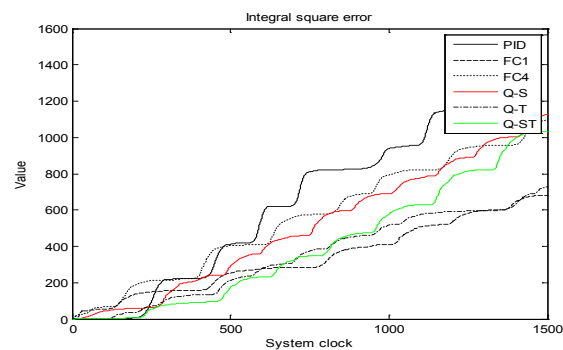

Figure 45. Integral of square error. Typical control situation. Experiment

Consider the results of an experiment in an unexpected control situation (C 2). In Figure 46-48 the results of experiments in an unexpected control situation are presented.

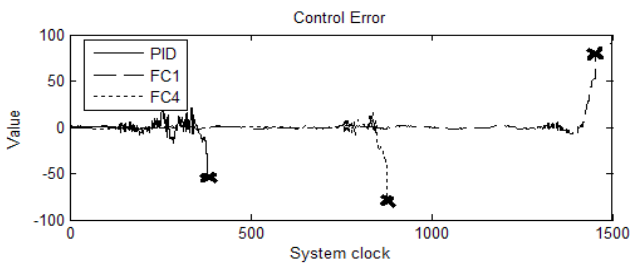

Figure 46. The angle of deviation of the layout. Unforeseen control situation. Experiment

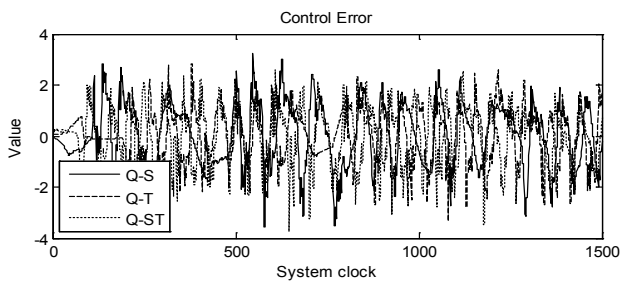

Figure 47. The angle of deviation of the layout. Unforeseen control situation. Experiment

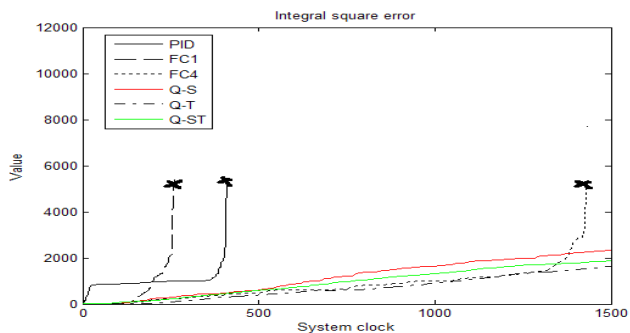

Figure 48. Integral of square error. Typical control situation. Experiment

The control evaluation showed that FC developed with the use of SCO provide the system with simpler control, which ultimately has a positive effect on the life of the equipment, reducing wear and power consumption. The developed methodology of combining control strategies allows to effectively cope with control tasks even in unforeseen situations, in which the task of control can't cope with the FC underlying the QFI. Thus, we have a new synergistic effect due to the quantum self-organization of knowledge: the intelligent controller designed on the ba-

sis of QFI copes with the task of control and has a robust KB, which is based on non-robust KB (see, Figures 43 and 44). At the same time, the QFI-based control system inherits the best control quality characteristics from the KB of previously designed fuzzy controllers, adding the ability to self-organize in on line.

Consider the behavior of PID and fuzzy controllers in an unforeseen control situation. Figure 49 presents the results of modeling and experiments in a unforeseen control situation.

The experiment compares the different types of control, such as PID controller, Fuzzy controller, the Quantum controller. In unforeseen control situation, the classical PID and fuzzy controllers did not cope with the control task. One can see the limitations of the possibilities of the classical regulator. Also, modeling showed limitations of the use of a fuzzy controller

In the Figure 49, a new synergistic effect of imperfect knowledge self-organization demonstrated. Individual regulators fail to task of control in unforeseen situation, but their joint using in a system with a quantum inference cope with the control goal task, and control output occurs in on line, without delays. And Figure 49 shows the unstable response of two fuzzy controllers and the stable response (of created from these fuzzy controllers) quantum controller to an unforeseen situation.

Technologies for remote configuration and transmission of knowledge bases allow the control object to receive knowledge bases from the optimizer block or from other control objects, which allows to control structurally new objects such as robot groups, multi-agent systems, complex automated production complexes. In addition, this technology allows the control object to update and adapt the knowledge base for a specific control situation using a real control object.

In the multi-agent system, there is a new synergetic information effect of self-organization of knowledge bases and formation of an additional information resource that arises in the exchange of information and knowledge between active agents (swarm synergetic information effect).

9. Modeling and an Interaction Experiment of a Group of Robots

The prototypes of a manipulator, an inverted pendulum and a mobile manipulator, act as mutual CO. The mobile manipulator equipped with an image recognition system based on the computer vision library OpenCV and such hardware as a Web camera, Kinect console and an infrared sensor. The decentralized and hierarchical variants of interaction of a group of robots are considered. An experi-

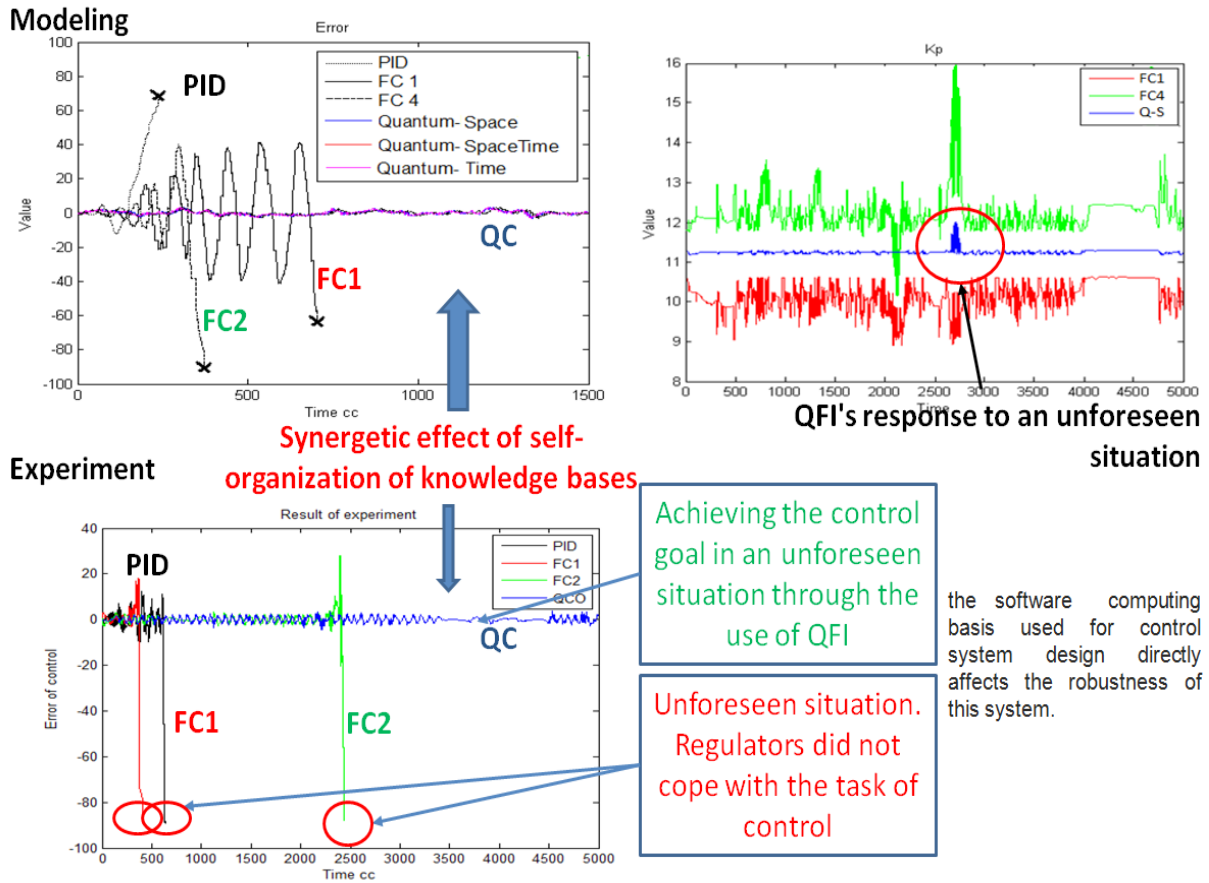

Figure 49. Unforeseen control situation

ment is shown in the "master-slave" connection conducted on the basis of the recognition system of the mobile manipulator.

Let us consider an example of applying ICS: a problem is considered, in which a glass is placed on top of the inverted pendulum. The mobile manipulator is equipped with an infrared camera that determines the relative position of the inverted pendulum and starts moving towards the recognized object. Also, the command to approach is sent to the inverted pendulum. After approaching, the mobile manipulator, using the recognition system and the Kinect camera, determines the location of the glass. The manipulator equipped with an ICS calculates the command to the engines in the links and moves the manipulator towards the glass. At first, the cart finds the inverted pendulum in the visibility zone and determines its position. If the pendulum is turned, then the command to swing is sent. If the pendulum is straight, then the mutual approach starts. When the distance becomes optimal for gripping the glass, the Kinect camera is turned on and the glass mounted on the pendulum is recognized. After recognizing the glass, the coordinates and the command to grip the glass are sent to the manipulator (Figure 50).

This interaction implements the hierarchical control in the master – slave combination. Thus, the inverted pendulum acts as a slave and executes commands from the mobile manipulator that has an additional sensor to determine the position of the pendulum. Such interaction is standard and possible to apply in a wide range of tasks. In addition to the obvious possibilities of automation of the cafes and bars, it is also possible to automate many production tasks, such as loading and unloading containers, sorting, etc.

The embedded level of computational intelligence in intelligent control systems of an inverted pendulum, a mobile trolley and a manipulator makes it possible to increase the robustness of the complex interaction of several robotic systems and ensure the achievement of the control goal with a high level of reliability.

Example: Quantum intelligent control of robotic manipulator. For completeness of material presentation adding that in the case of interaction of a group of robots, ICS were developed for each system separately. For example, using QFI allowed to manipulator:

- solving the problem of positioning in regular situations;

- improving the results of the positioning task in conditions of external unforeseen situations (under internal unforeseen situations the results do not change at best);
- increase in the criterion Performance by 5 times;
- improving the assessment of general management, the best result is achieved by using spatial correlation of all seven FC's.

Figure 51 shows results simulation of manipulator control.

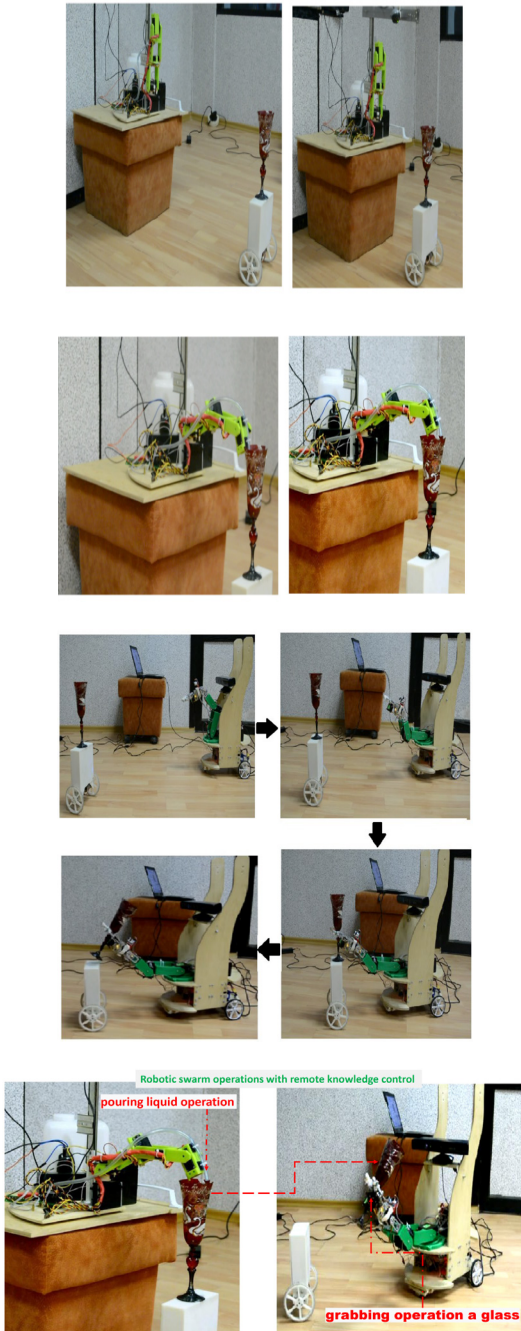

Figure 50. Mobile manipulator performs gripping of the glass with an inverted pendulum

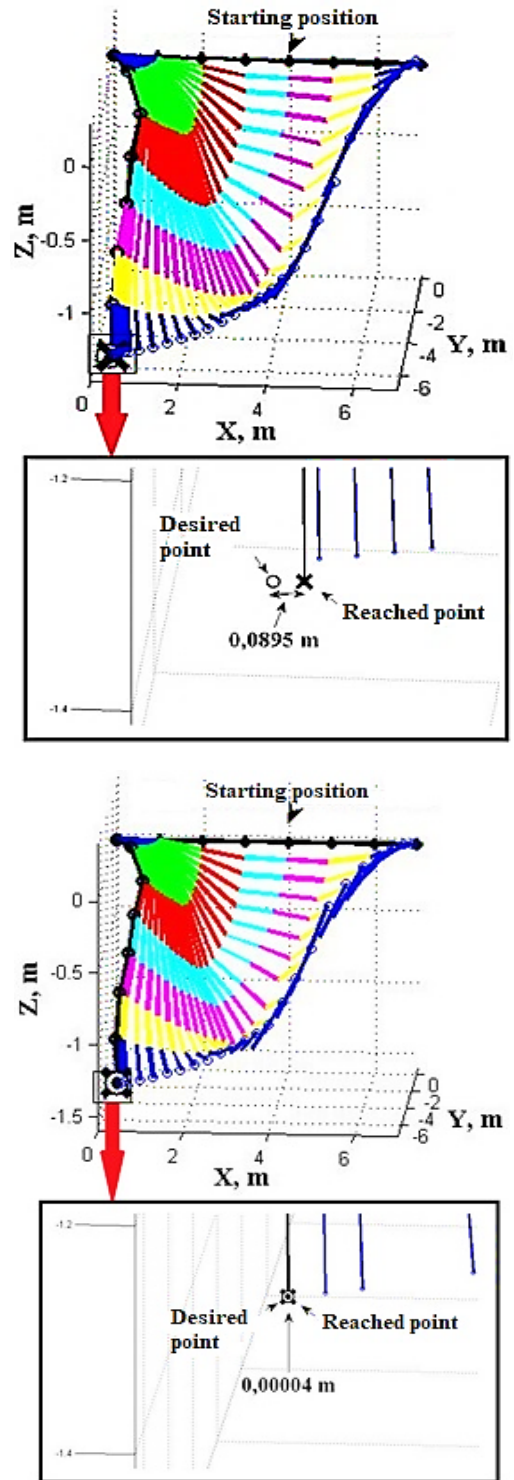

Figure 51. The movement of manipulator in a standard control situation: under control of ICS based on SCO with soft computing (left); ICS based on SCO with quantum computing (right)

It should be noted that increasing the level of accuracy (more than 10^4 times) of manipulator control is a key factor to improve the reliability of achieving the goal of

quantum intelligent control in a complex task with the cognitive interaction of a group of robots. So, the operation of capturing the glass, which in turn is a dynamically unstable object, requires the control system to develop such a control action that would compensate for the inaccuracy of the pendulum and the mobile cart.

10. Conclusions

The information technology of knowledge base remote design and transmission of the smart fuzzy controllers with the application of the "Soft / quantum computing optimizer" software toolkit developed.

The physical realization of SW/HW applications of the transmission and communication system between robots using remote connection the knowledge bases to the intelligent controllers considered.

A comparison of the control quality between fuzzy controllers and quantum fuzzy controller in various control modes demonstrate the quantum supremacy of quantum fuzzy controller.

Analysis of the experiments shows the possibility of the ensured achievement of the control goal of a group of robots using soft / quantum computing technologies in the design of knowledge bases of smart fuzzy controllers in quantum intelligent control systems.

The ability to connect and work with a physical model of control object without using than mathematical model demonstrated.

References

- [1] Peres, R.S. et al. Industrial Artificial Intelligence in Industry 4.0 Systematic Review, Challenges and Outlook [J]. IEEE Access. / SPECIAL SECTION ON ADVANCED ARTIFICIAL INTELLIGENCE TECHNOLOGIES FOR SMART MANUFACTURING, 2020, 8: 220121 - 220139.
- [2] Ulyanov, S. V. Quantum fast algorithm computational intelligence PT I: SW / HW smart toolkit [J]. Artificial Intelligence Advances, 2019, 1(1): 18-43. <https://doi.org/10.30564/aia.v1i1.619>.
- [3] Ulyanov, S. V. Quantum Algorithm of Imperfect KB Self-organization Pt I: Smart Control-Information-Thermodynamic Bounds [J]. Artificial Intelligence Advances, 2021, 3(2): 13-36. <https://doi.org/10.30564/aia.v3i2.3171>.
- [4] Huba, M., Vrancic, D. Comparing filtered PI, PID and PIDD2 control for the FOTD plants [P]. IFAC Papers On Line, 2018, 51(4): 954–959 [Available online at www.sciencedirect.com].
- [5] Keramat, R. et al. A Comparison of Fuzzy and Brain Emotional Learning-Based Intelligent Control Approaches for a Full Bridge DC-DC Converter [J]. International Journal of Industrial Electronics, Control and Optimization, 2019, 2(3)6: 197-206.
- [6] Vrancic, D., Huba, M. High-Order Filtered PID Controller Tuning Based on Magnitude Optimum [J]. Mathematics, 2021, 9: 1340. <https://doi.org/10.3390/math9121340>.
- [7] Das, S. et al. Performance Analysis of Robust Stable PID Controllers Using Dominant Pole Placement for SOPTD Process Models [R]. arXiv: 1801.09238, 2018.
- [8] Sahib, M.A. A novel optimal PID plus second order derivative controller for AVR system [J]. Intern. J. Eng. Sci. and Techn., 2015,18: 194-206 (<http://creativecommons.org/licenses/by-nc-nd/3.0/>).
- [9] Zaidel, Y. et al. Neuromorphic NEF-Based Inverse Kinematics and PID Control [J]. Frontiers in Neuro-robotics, 2021, 15(Article 631159) [www.frontiersin.org].
- [10] Juniku, I., Marango, P. PID design with bio-inspired intelligent algorithms for high order systems [J]. INTERN. J. MATHEMATICS & COMP. IN SIMULATION, 2015, 9: 44-59.
- [11] Agha, A. et. al. NeBula: Quest for Robotic Autonomy in Challenging Environments; TEAM CoSTAR at the DARPA Subterranean Challenge (preprint version) [R]. arXiv:2103.11470v1 [cs.RO] 21 Mar 2021.
- [12] Hudson, N., et al. Heterogeneous Ground and Air Platforms, Homogeneous Sensing: Team CSIRO Data 61's Approach to the DARPA Subterranean Challenge [R]. arXiv:2104.09053v1 [cs.RO] 19 Apr 2021.
- [13] Jagatheesaperumal, S.K. et. al. The Duo of Artificial Intelligence and Big Data for Industry 4.0: Review of Applications, Techniques, Challenges, and Future Research Directions [R]. arXiv:2104.02425v1 [cs. AI] 6 Apr 2021.
- [14] World Robotics 2016 Service Robots. International Federation of Robotics (IFR) [R]. 2016.
- [15] CORBYS Cognitive Control Framework for Robotic Systems (FP7 – 270219). Deliverable D2.1 Requirements and Specification [R]. 2011.
- [16] Yang, G.-Z. The grand challenges of *Science Robotics* [J]. Sci. Robotics, 2018, 3: 7650.
- [17] Sniderman, B. et al. Industry 4.0 and manufacturing ecosystems [M]. Deloitte's Univ. Press, 2020.
- [18] White Paper: AI in Industrial Automation [R]. German Electrical and Electronic Manufacturers' Association, 2021.
- [19] Ulyanov, S.V. Self-organizing quantum robust control methods and systems for situations with uncertainty and risk [P]. Patent US 8788450 B2, 2014.

- [20] Ulyanov, S. V. Self-organized robust intelligent control [M]. Saarbrücken: LAP Lambert Academic Publishing, 2015.
- [21] Ulyanov, S.V. Quantum relativistic informatics [M]. LAP LAMBERT Academic Publishing, OmniScriptum GmbH & Co. KG, 2015.
- [22] Ulyanov, S.V. System and method for control using quantum soft computing [P]. Patent, US 6,578,018, B1, 2003.
- [23] Litvintseva, L. V., Ulyanov, S. V. Intelligent Control Systems. I. Quantum Computing and Self-Organization Algorithm [J]. Journal of Computer and Systems Sciences International, 2009. 48. (6): 946 - 984. DOI: 10.1134/S1064230709060112.