

REVIEW

Knot Types Used by Transformable and Rigid Linear Structural Systems

M^a Dolores Álvarez Elipe*

Estética y Teoría de las Artes, URJC, Madrid, Spain

ARTICLE INFO

Article history

Received: 13 January 2022

Revised: 9 April 2022

Accepted: 29 April 2022

Published Online: 10 May 2022

Keywords:

Knot

Join

Structure

Geometry

Force

Rigid

Embedment

Articulated

Slip

ABSTRACT

A knot is the joining place between two or more constructive elements in a framework or structure. They have a fundamental importance in the structure, according to their design they will be able to give a geometric configuration or another to the system and will also absorb certain forces or others. Depending on the movements they allow to the bars, there are rigid knots, articulated knots and slip knots. In this paper a study of cases about rigid knots or embedments used by structural systems so far will be presented. These types of knots prevent the rotation and movement of the constructive elements used for construction. In this paper also a study of cases about the articulated and slip knots used by transformable structural systems so far will be presented. An articulated knot allows the rotation but not the movement of the elements. A slip knot prevents movement in one of the three axes of the reference system, but not in the others, nor in the rotation between the elements. The research is focused on presenting a summary and comparison of rigid knots, articulated knots and slip knots that have been used in the structural design of some architecture. The union systems research will be crucial in this study. The investigation shows an important state of the art that provides technical solutions to apply on novel architectures based on rigid structural systems and articulated and slip structural systems. The research is useful to produce the current constructive solutions based on these constructive systems.

1. Introduction

According to construpedia^[1]:

A rigid knot is the type of knot that avoids turns and displacements of the elements. It is called embedment too.

An articulated knot is the type of knot that allows the rotation but not the movement of the elements. It is called articulation too.

A slip knot is the type of knot that prevents movement

in one of the three axes of the reference system, but not in the others, nor in the rotation between the elements.

The research is focused in summarize and compare types of rigid knots, articulated knots and slip knots that have been used in the structural design of some architecture. The research of adequate forms and geometries will be crucial in this study. The investigation presents an important state of the art that provides technical solutions to apply on novel architectures based on rigid, articulated and slip

*Corresponding Author:

M^a Dolores Álvarez Elipe,

Estética y Teoría de las Artes, URJC, Madrid, Spain;

Email: mdolores_500@hotmail.com

DOI: <https://doi.org/10.30564/jaeser.v5i2.4352>

Copyright © 2022 by the author(s). Published by Bilingual Publishing Co. This is an open access article under the Creative Commons Attribution-NonCommercial 4.0 International (CC BY-NC 4.0) License. (<https://creativecommons.org/licenses/by-nc/4.0/>).

structural systems. The research is useful to produce the current constructive solutions based on these constructive systems.

The goal is to understand any current rigid, articulated and slip knots to know their configuration and the advantages and disadvantages of them. It is collected for the knowledge of rigid, articulated and slips knots to the artists, architects, engineers and all types of people.

Some examples of this rigid knots are Pyramitec, Tridimatec, Unibat, Sphérobot, Trio-detic, Segmo, Tubaccord, Bourquardez, Begue, Chamayou, Begue-kieffer, Delacrix-glottin-monier-sejournet, Kieffer, Sarton, Spherical, Bitubular, Tesep, Unistrut, Mero, Wupperman...

Examples of some type of articulated and slip knots will be presented too. These types of knots are inside of this classification: knots by rotation of the bar, hinged knots, bolted or pin knots and knots per bearing. Authors like Fuller, Pérez Piñero, Albert Moore, Zeigler, Swetish and Baumann, Daniel S-H Lee, Olga Popovic Larsen and Seung-Deog Kim, SeungDeog KIM, SunKyeong PARK, JePil JANG, InA SIN, JangBog LEE, ChangWoo HA and SeungTeak JUNG, Yohei Yokosuka and Teruo Matsuzawa, Jesús Anaya, M^a Dolores Álvarez and Ramón Serrano will be studied.

The research is supported by geometrical basic criteria.

2. Knot Types Used by Rigid Linear Structural Systems

The evolution of rigid knots will be studied to generate a synthesis of the novelties than have been developed in this area. All of that is possible because of the study of some authors and some existing patents.

2.1 Stéphane du Château

Stéphane du Château ^[2] is a French-Polish architect and urban planner that invents the construction systems as Pyramitec, Tridimatec, Unibat and Sphérobot knots.

Du Château created his first system of spatial structure – the tri-directional SDC (Figure 1) in 1956 ^[3]. He obtained his patent in 1957 and after he applied it to cover the lobby of the power station on the Grandval Dam (1957-1958), designed by the architect H. Marty ^[4,5]. The knot can be used to single layer tights. They are prepared to the assembly and welding of the concurrent bars. The knots have been used in double layer tights, attaching the diagonal bars to the shells. The tube bars are welded to the nodes after the adjustment of the whole structure.

The SDC knot resolved three problems mainly ^[2]:
Every knot receives six members.

The constraint length is resolved independently of the

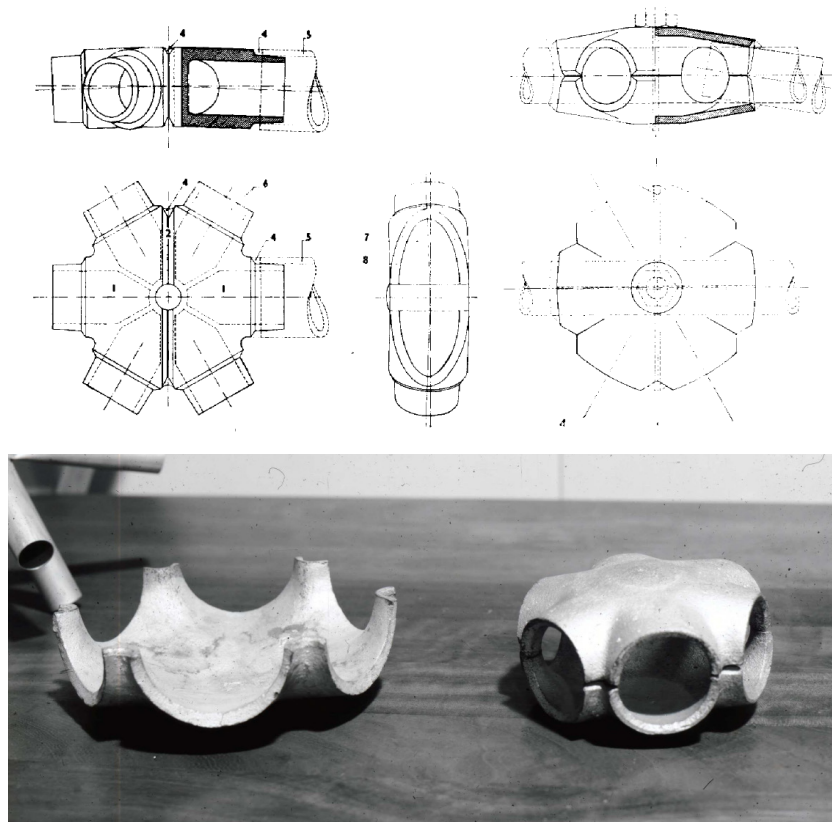


Figure 1. SDC knot, draws and prototype, Stéphane du Château (1956) ^[2]

tube length introduced into the node. All members can have the same size. The variations are absorbed by the penetration length into the node.

The curvature is possible. The spaces into the knot allow proportionate the required limb inclination (only a few degrees are enough).

Later, he discovered a new system which led him to develop four construction patents, many realizations and publications in the 1960s. Realizing the difficulty of in situ welding in construction, Stéphane du Château proposed the Pyramitec system (Figure 2), where the connections are realized by the use of screws ^[4]. This system is characterized by the application of pyramids that determine the inertia of the structure. It was used in the realization of the National Exposition Fair of Nancy (1963-1964, by the architects M. Kruger and M. Pierron).

It is formed by a cylindrical central body that can receive the bars of one level of the mesh. It also has a truncated cone, where the diagonal bars are screwed. To make this system prefabricated is feasible. The assembly is easy and it is preferably done on the ground and standing up after assembly. These structures used as roofs, can adopt flat, inclined, slightly curved shapes and in certain cases they can form domes.

The pyramids could not exceed three meters due to the transportation. By this reason Stéphane du Château proposed the Tridimatec System (Figures 3 and 4). It is constituted by the use of beams in meshes, where their ends are connected in such a way that they form a system of crossed beams ^[5]. With an accessory formed by two crossed plates, the possible number of concurrent bars in this node is increased.

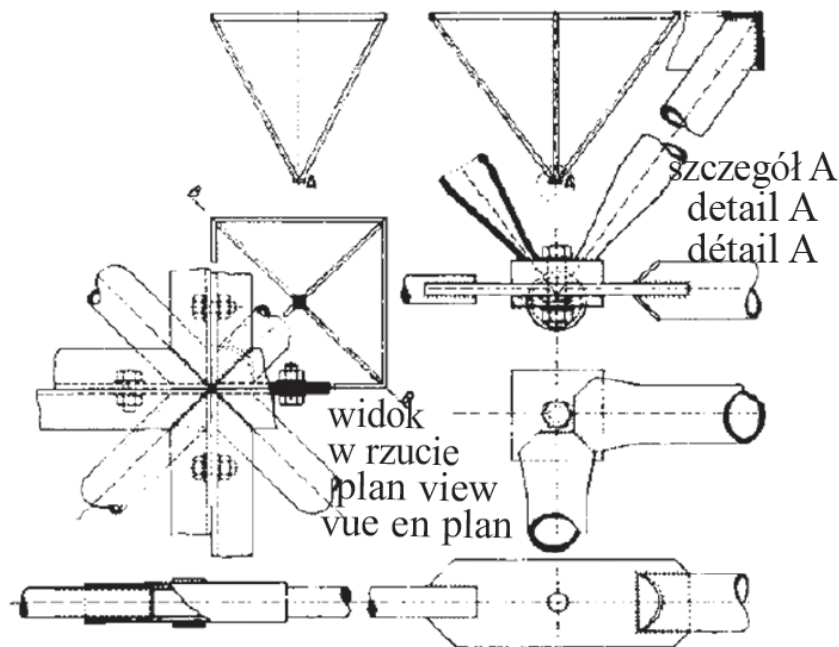


Figure 2. Ortoogonal System Pyramitec (pyramid with square base), Stéphane du Château (1963) ^[4]

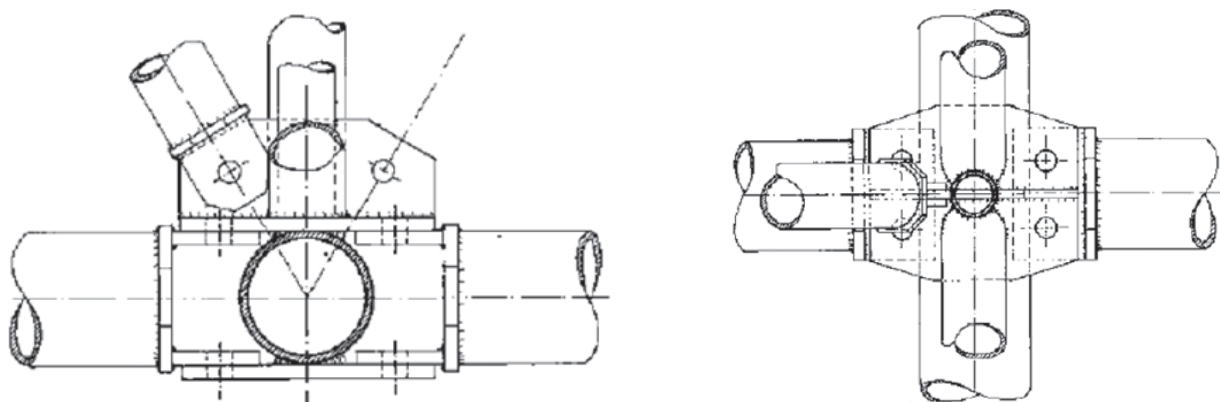


Figure 3. Draws of details of Tridimatec system: view of the connector for a two-dimensional grid, Stéphane du Château (1964) ^[5]

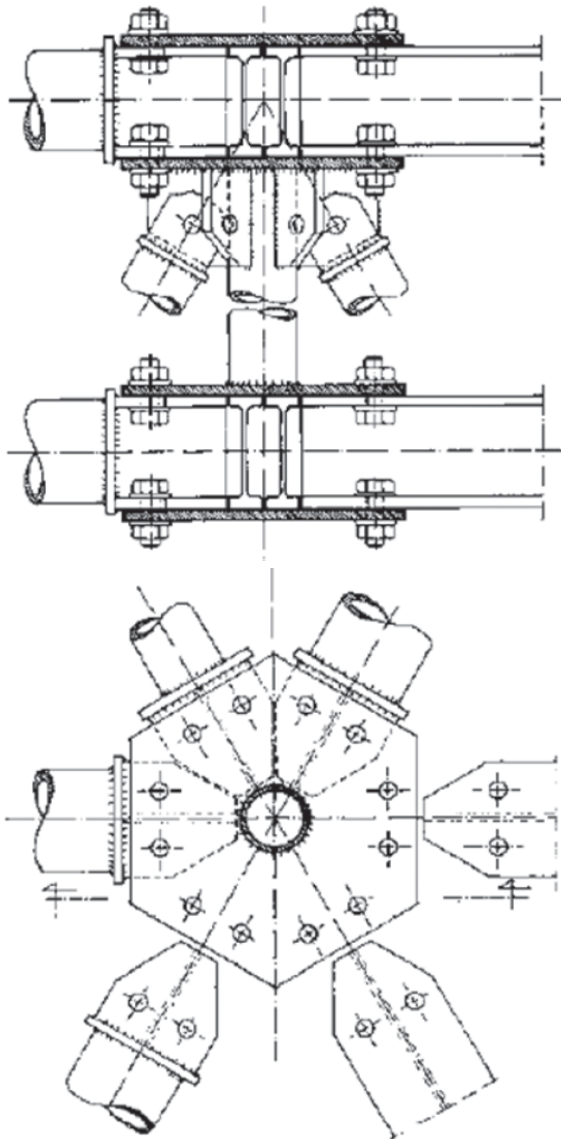


Figure 4. Draws of details of Tridimatec system: view of the connector for a three-dimensional grid, Stéphane du Château (1964) ^[5]

The great flexibility of the Pyramitec system application, with its different geometries of construction elements, evolves towards the Unibat system (Figure 5). The geometry of Unibat is formed by a board of pyramids and squares ^[5]. It only covers the 50% of the surfaces with pyramids, which is more economic. The square-based pyramids are connected in pairs using one of their base angles and connecting their tops with bars. This connection corresponds to a three-dimensional structure with two parallel layers. The meshes of the superior layer are constituted by the bases of the pyramid and they are oriented 45° in relation with the layers of the inferior layer, constituted by bars that merge the ends of the pyramids. This system is useful, according to its scale, to

make slabs, roofs or urban macrostructures. This system has good behavior in an immense variety of programs and, mainly during the 1970s; its efficiency was proved by carrying out fifty projects in France and abroad.



Figure 5. Unibat system, Stéphane Du Château (1970) ^[5]

Even though Unibat was successful, Du Château's realizations needed another system with nodes and members, which were easier to transport than the pyramids. All specialists knew about the success of the "Mero" knot in these years, and took advantage of the competition for the Baltimore airport (1975) to use it. However, Du Château designs a perforated sphere that can receive the members. Afterwards, the investigation of a spherical knot which set of members could have any relative position, end up developing the Spherobot knot (Figure 6). This knot is realized with two pieces: one of these is the third part of a sphere; the other is two thirds of the sphere ^[5].

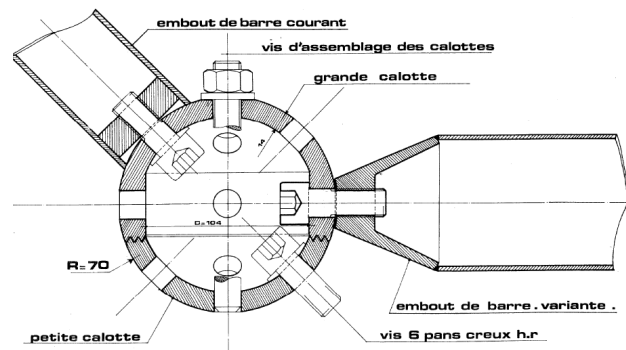


Figure 6. Spherobot, Stéphane Du Château (1975) ^[5]

Apart of the knots realized by Stéphane Du Château, it is realized a classification of rigid knots, presented in continuation.

2.2 Trio-detic Knot

The Trio-detic system (Figure 7) is originally from Canada. This system was developed during 1950's by the Fentiman Bros Company ^[6]. The patent is to be used in a reticulate of three directions. The bars are plane in their ends and they are introduced by pressure in serrated grooves that exist in the knots. The principal characteristic is that the union of the bars is realized with no welding, no bolts and no rivets. The distribution of the bars that go to the node determines its shape.



Figure 7. Trio-detic knot, Fentiman Bros Company [6]

The knot of the Trio-detic system will be the base of the design of some prefabricated systems, like the protected ones under the patent WO 2006097545 A1, whose date of presentation is 16th March 2005 and its date of publication is 21st September 2006. Its inventor is Juan Carracedo Planelles and the solicitant is Montur Estan, S.L. [7].

2.3 Makowski Dome Knot

The knots of Makowski dome (Figure 8) are metal caps to which the tubular bars are attached by means of pins [8].

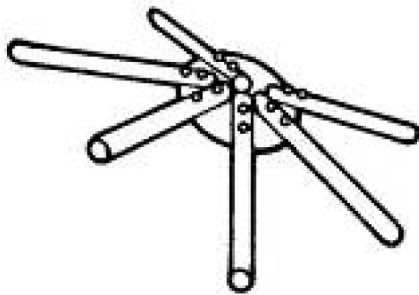


Figure 8. Makowski dome knot [8]

2.4 Segmo Knot

Segmo Knots (Figure 9) are welded steel. It is composed by two parts: one spherical and one prismatic. The bars are fixed by welding or by any other mechanical means [8].

It is a variant of the previous one; the tubes have at their ends a stem that is inserted into existing holes in the node. It allows joining by rivets and bolts with the annular disk of both parts.

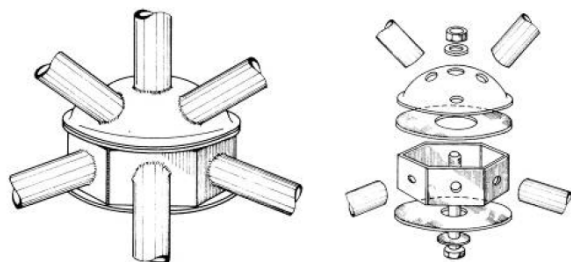


Figure 9. Segmo knot [8]

2.5 Tubaccord Knot

In the Tubaccord knot (Figure 10) the tubular bars are either directly welded or fixed by means of pins that

fit into grooves located at the ends of the bars and in a sleeve previously welded to the bar of greater diameter concurrent to the node [8].

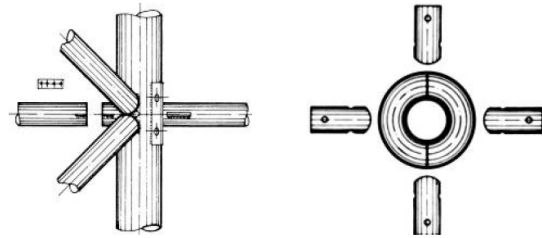


Figure 10. Tubaccord knot [8]

2.6 Bourquardez Knot

The bourquardez knot (Figure 11) is composed by one or some torus, obtained by joining two 180° elbows and tubular sleeves welded to said torus. The concurrent bars in the node are attached to the sleeves by means of riveting [8].

Figure 11 represented a knot prepared to meshes of one layer and one knot to meshes of two layers.

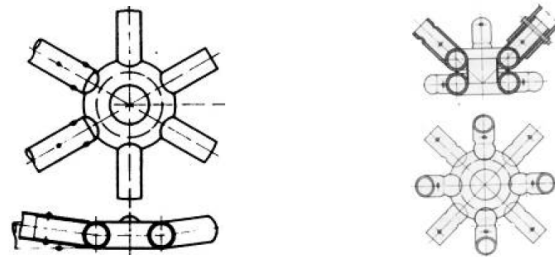


Figure 11. Bourquardez knot [8]

2.7 Begue Knot

The Begue knot (Figure 12) is formed by a nucleus to which the bars with frustoconical ends are screwed [8].

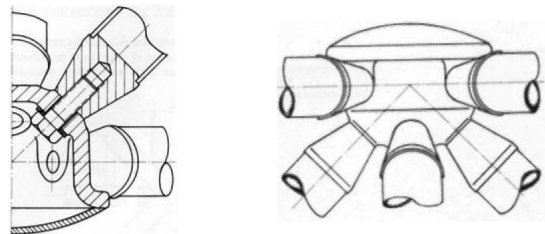


Figure 12. Begue knot [8]

2.8 Chamayou Knot

The Chamayou knots (Figure 13) can be planes, flanged along a closed polygonal line, or cubic or tetrahedral in shape, with the same flanges on each of the edges. The flanges are squares, polygonal sections or with the shape of a surface of revolution (cylinder, torus, etc.), and to

them the tubular bars are fixed by means of clamps^[8].

Figure 13 represented a plane knot with hexagonal shape.

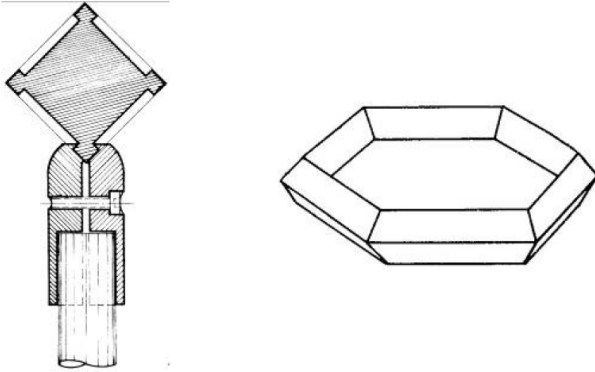


Figure 13. Chamayou knot^[8]

2.9 Begue-kieffer Knot

The Begue-kieffer knot (Figure 14) is formed by a sphere with some starts with two grooves in order to fix the tubes^[8].

This fixing is carried out by means of a hydraulic group, located on the ground, which presses a collar arranged around the tube and on the grooves of the boot, previously inserted on it. This is how the bar fits into the boot through the slots.

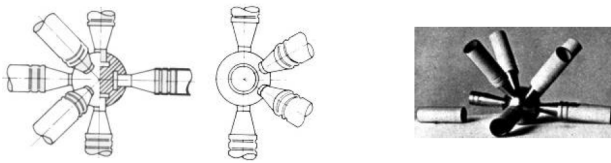


Figure 14. Begue-kieffer knot^[8]

2.10 Delacrix-glotin-monier-sejournet Knot

Delacrix-glotin-monier-sejournet knot (Figure 15) is formed by one or two semi-tubes with welded fins that indicate the directions of the concurrent bars. These semi-tubes are joined by means of rivets or welding to the concurrent bar of greater diameter of the node. The remaining bars are fixed by crushing their ends and joining them, by means of welding or pins, to the fins^[8].

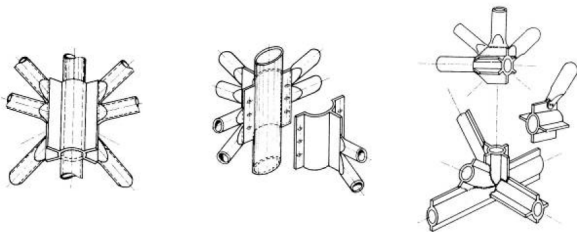


Figure 15. Delacrix-glotin-monier – sejournet knot^[8]

2.11 Kieffer Knot

Kieffer knot (Figure 16) is formed by a solid central cylinder, its function is to be the pin for the entire knot, which consists of two concentric cylinders, the outer one with grooves that hold the welded ribs at the ends of the concurrent bars^[8].

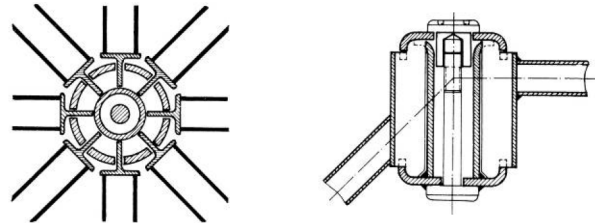


Figure 16. Kieffer knot^[8]

2.12 Sarton Knot

The process to obtain the Sarton knot (Figure 17) consists in flattening the pipes at the points corresponding to a knot, in order to be able to cross them comfortably and place a pin with a fixing thread^[8].

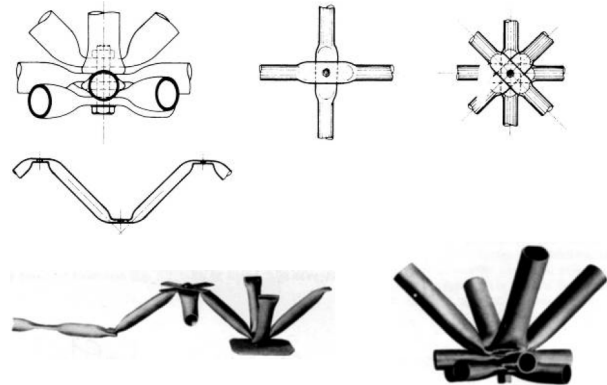


Figure 17. Sarton knot^[8]

2.13 Spherical Knot

The Spherical knot (Figure 18) is constituted by a sphere where bars are joined, by welding, in any direction. To absorb differences in the tube lengths, a sleeve with a greater diameter is welded to the node. The sphere is usually filled with mortar as safety against possible sagging of itself^[8].

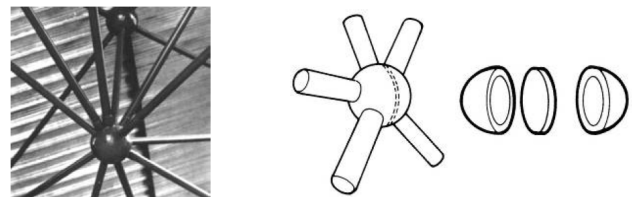


Figure 18. Spherical knot^[8]

2.14 Bi-tubular Knot

The Bi-tubular knot (Figure 19) is constituted by two tubes, joined in parallel, where the concurrent bars are welded^[8].

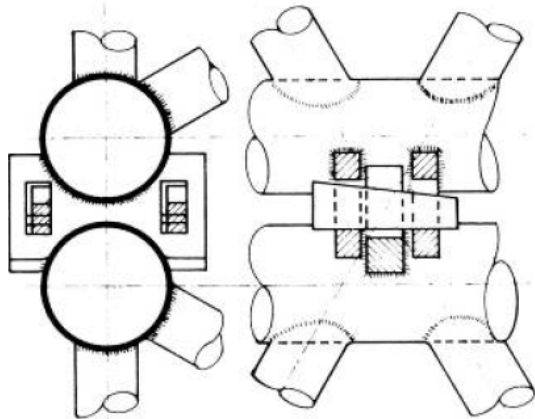


Figure 19. Bi-tubular knot^[8]

2.15 Tesep Knot

The concurrent bars in the Tesep knot (Figure 20) are joined directly by welding to the larger diameter or by screwing ribs, welded at their ends, to a plate that is also welded and perpendicular to the central tube^[8].

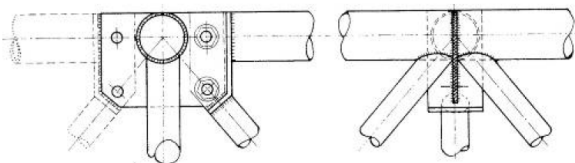


Figure 20. Tesep knot^[8]

2.16 Unistrut Knot

The Unistrut knot^[5] consist in the utilization of two pieces of folded sheet metal that overlap and where the bars are attached by pins (Figure 21). The bars are profiled and the knots mare made of stamped sheet metal. In this system, all the elements used have the same length and are joined by identical devices.

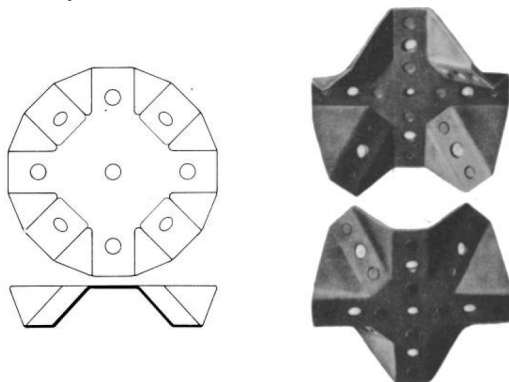


Figure 21. Unistrut knot^[5]

2.17 Mero knot

The Mero structural system^[4] is employed in tubular constructions of steel to fixed and provisional type works (fixed warehouses, frame structures, scaffolding, supports, etc.). It is formed by octagons, inscribed in a sphere, where a previously prepared bar can be screwed.

The MERO system was used by Mengerinhausen before of the Second World War.

Its two basic elements are: the connection spheres in which 18 octagons are inscribed with one threaded hole for each one and the bars that are threaded into the holes. The bars length must be equal.

Every knot can group the ends of the 18 bars without eccentricity. It is a light system that permits a maximum of prefabrication and in the assembly, specialized personnel is not necessary. The usual meshes are:

Squares of 0.5 m; 1.0 m; 2.0 m side and their corresponding diagonals.

Those formed by equilateral triangles of 0.7 m; 1.4 m or 2.8 m on a side.

This results in angles of 45°, 60° or 90° respectively, between the bars.

The Mero structures can be assembled quickly with unskilled labor. The transport of the elements is easy and cheap. The system is very flexible in terms of the variety of geometric shapes that it can adopt.

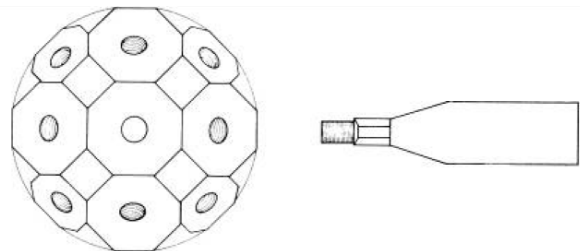


Figure 22. Mero knot^[4]

2.18 Wupperman knot

The Wupperman knot (Figure 23) developed by the sign of Theodor Wupperman is used in spatial reticular systems of one layer. It is formed by a hexagon where the concurrent bars are screwed in six possible directions. The bars are profiled^[8].



Figure 23. Wupperman knot^[8]

3. Knot Type Used by Transformable Structural Systems

The evolution of articulated and slip knots will be studied to generate a synthesis of the novelties that have been developed in this area. All of this is possible because of the study of some authors and some existing patents.

3.1 Knots Classification of Transformable Structural Systems According to Their Movements

All transformable structure needs mechanisms in the joints to realize the process of pliability, unfolding, opening, closed or deformed. First of all, it is possible to determine that the movements in the joins can be in the plane or in the space. The movements of one bar in the plane are three: one turn and two displacements “u” and “v”. But in the space, one bar has six possible movements: 3 turns and 3 displacements.

When the book “Synthesis of mechanisms” of Nieto [9] is revised, it can be said that the kinematic torque is the joint, with the faculty of movement, of two bars, so that the bars present a relative movement of certain characteristics due to the constraints imposed by this joint. According to the geometric locus described by any point of a bar in the relative movement of both, they are classified into: first degree or linear pairs, if the locus is a line; second degree or surface pairs, if the locus is a surface; and third degree or spatial pairs, if the locus is a region of space (Figure 24).

According to the degrees of freedom number possessed by the relative movement of the two bars that make up the

pair, they are classified into: pairs of one, two, three, four and five degrees of freedom, or pairs of class I, II, III, IV and V, respectively (Figure 25).

Rodríguez [10] attempts to summarize the types of nodes regardless of the conditions of the members (Figure 26).

The first two, rotating and hinged knots, are simple solutions that can be located in the center of the bar or at its ends. The last two cases, pin knot and rolling, are more complex. In addition to rotating the bar, the entire structure changes its position. In these types of knot, the clearances are an important requirement to allow the passage of the bar through its different stages.

3.2 Patents of Knots of Transformable Structural Systems

In continuation, the knots that have been emerging as patents since deployable bar structures began to be developed and their authors will be chronologically exposed.

3.2.1 Fuller

As a great exponent of this area of the structures in that years can be cited R. Buckminster Fuller, who develops his first patent of geodesic dome “Building construction” in 1951 [11], and where can be found a knot with a ball-like cuff configuration. The pieces are held together by means of a bolt, with a coil spring being provided to provide a certain amount of elasticity in the fixation, which is particularly useful during the erection of the structure (Figure 27).

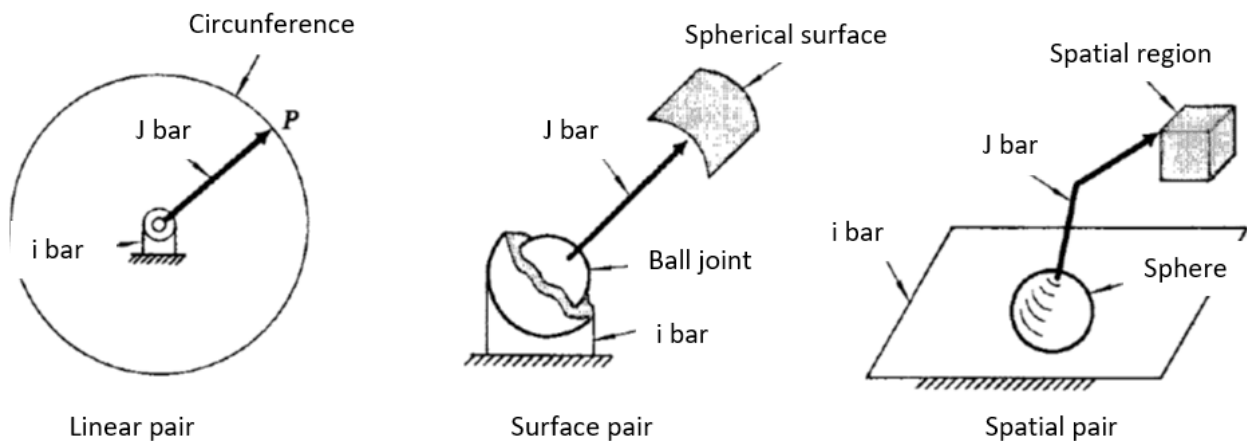


Figure 24. Classification of kinematic torques, Nieto (1978) [9]

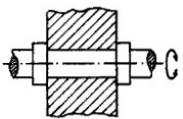
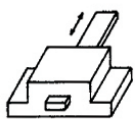
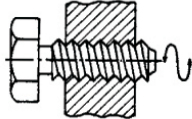
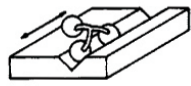
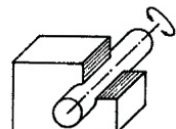

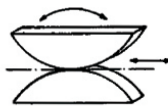
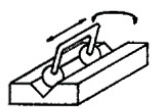


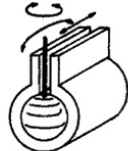
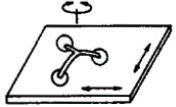
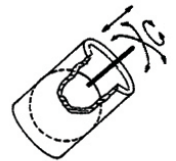
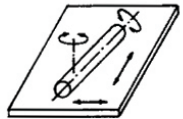
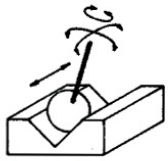
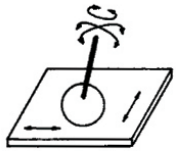

Clase	Grados de libertad	Esquemas, nombres y símbolos de pares cinemáticos			
I	1	 Par de revolución <i>R</i>	 Par prismático <i>P</i>	 Par helicoidal <i>H</i>	 Contacto pentapuntual
II	2	 Par cilíndrico <i>C</i>	 Par esférico ranurado <i>E_r</i>	 Par de leva <i>L</i>	 Contacto tetrapuntual
III	3	 Par esférico <i>E</i>	 Par plano <i>P_l</i>	 Par cilíndrico ranurado <i>C_r</i>	 Contacto tripuntual
IV	4	 Par esfera cilindro <i>E_c</i>	 Par plano cilindro <i>P_c</i>	 Contacto bipuntual	
V	5	 Par esfera plano <i>E_p</i>	 Par esfera esfera <i>E_e</i>		

Figure 25. Classification of kinematic torques according to the number of degrees of freedom, Nieto (1978) ^[9]


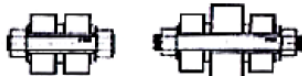


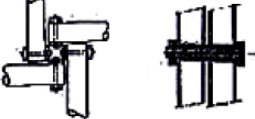
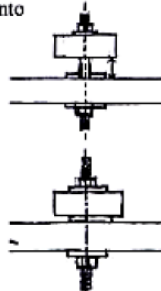
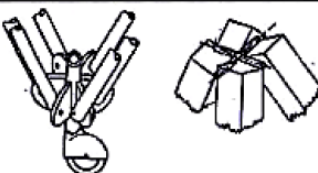
TIPO DE NODO	GRAFICO	CONDICIONES
Por Rotación de la Barra		Pueden llegar a el Nodo varias barras 
A bisagrado		
Atornillado o por pasador		Las holguras son necesarias para el movimiento 
Por Rodamiento		

Figure 26. Classification of the transformable structures knots, Rodríguez (2005) ^[10]

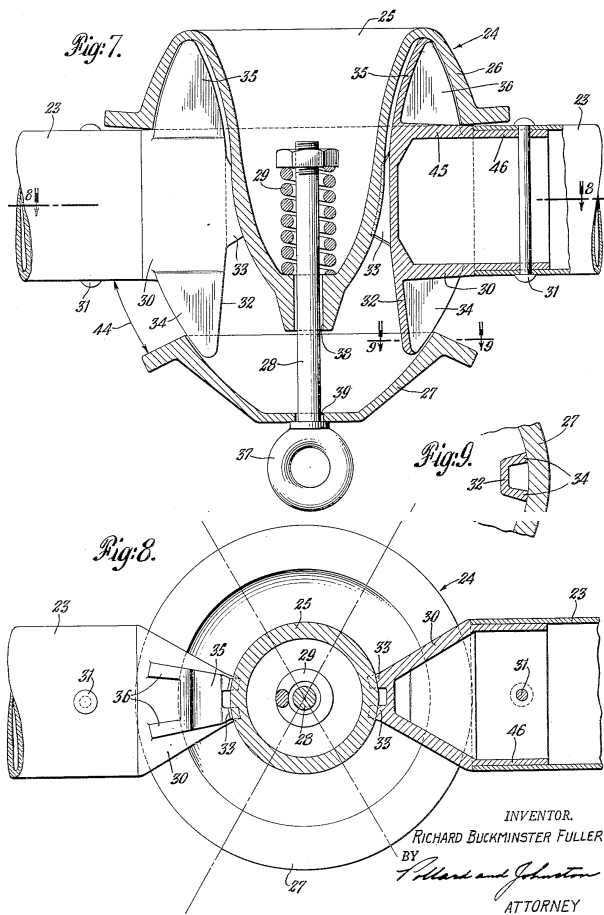


Figure 27. Knot of the geodesic dome “Building construction” (Fuller, 1951) ^[11]

In 1953 Fuller designed a tripod for their geodesic domes connected by hinged knots and called the Flying Seedpot (Figure 28). This project was realized together with his students with the objective of developing a house capable of being transported on the nose of a space shuttle and being automatically deployed on the lunar surface in 45 seconds. This project was never patented ^[12].



Figure 28. Flying Seedpot (Fuller, 1953) ^[12]

3.2.2 Pérez Piñero

In 1961 Pérez Piñero presents his design of a reticular dome that is deployed being completely prefabricated in his patent ES-0266801_A1 ^[13]. Emilio Pérez Piñero couples three sliding bars in an intermediate node (Figure 29).

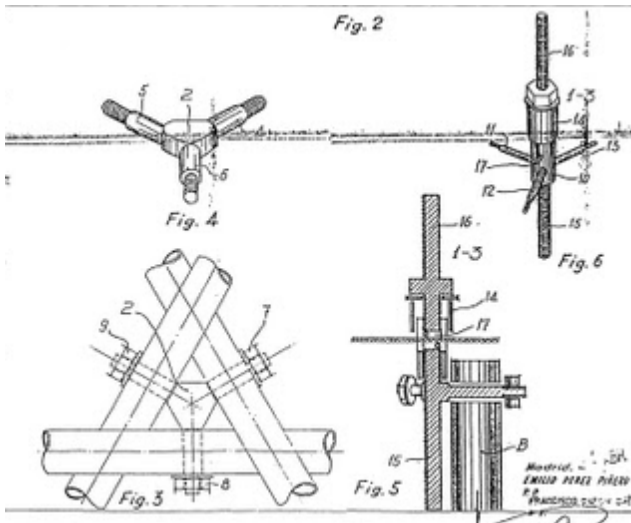


Figure 29. Knot of the patent ES-0266801_A1, Emilio Pérez Piñero (1961) [13]

3.2.3 Albert Moore

Later, in 1967, Albert Moore patented a system of dome called “Pre-assembled structural framework” [14]. It consists of a double curvature triangulated vault with a knot formed by a ring where all the bars reach (Figure 30).

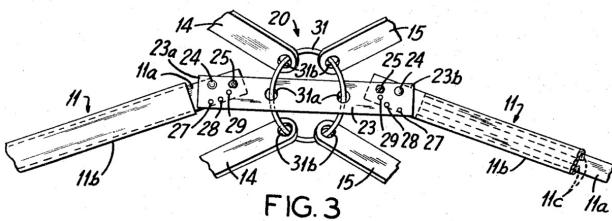


Figure 30. Knot of the patent US3325958, Albert Moore (1967) [14]

3.2.4 Zeigler

In 1977 the patent of Zeigler is published [15], where the points of cross of rod elements crossed in the structure involved may include limited slip connections that affect transfer of contraction force to other cross points that are pivotally attached (Figure 31).

In 1984, based on the Piñero’s work, Zeigler patented [16] a self-supporting structure in its deployable form without the need of stiffening elements (Figure 32). The movement is obtained by the used of bolts.

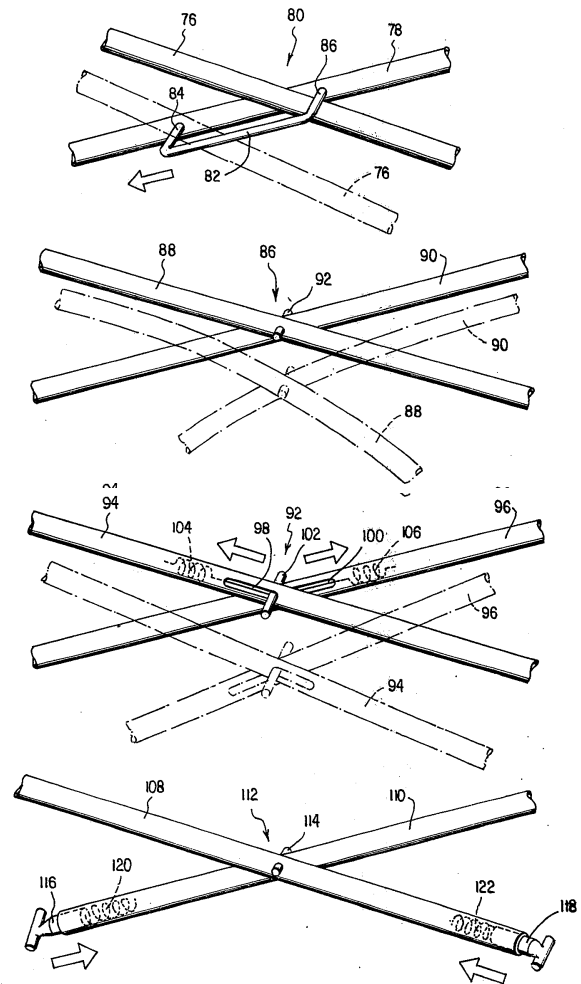


Figure 31. Sliding bar knots, patent US4026313, Zeigler (1977) [15]

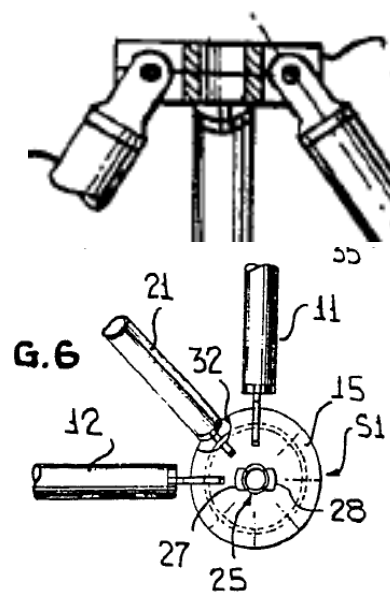


Figure 32. Knot of the patent US4473986A, Zeigler (1984) [16]

3.2.5 Swetish and Baumann

Swetish and Baumann ^[17] designed some pivoting joints between adjacent support poles for rotation about an axis parallel to the support poles (Figure 33). Each support pole moves between an extended position where the support pole extends perpendicular to the transverse poles and a collapsed position where the support pole extends along the transverse poles.

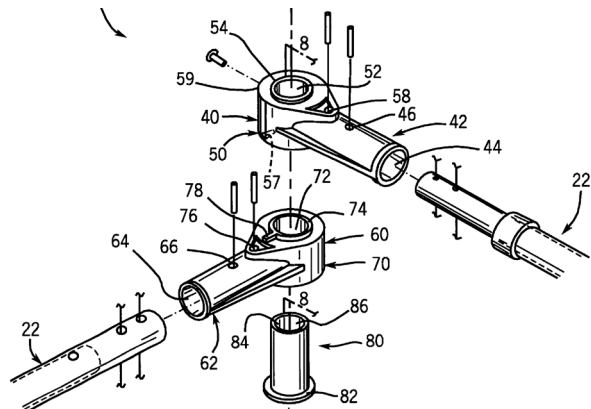


Figure 33. Knot of the patent US 6591849 B1, Swetish and Baumann (2003) ^[17]

3.2.6 Daniel S-H Lee, Olga Popovic Larsen and Seung-Deog Kim

Daniel S-H Lee, Olga Popovic Larsen and Seung-Deog Kim ^[18] developed a knot with two hinged connections that allow horizontal and vertical rotation (Figure 34).

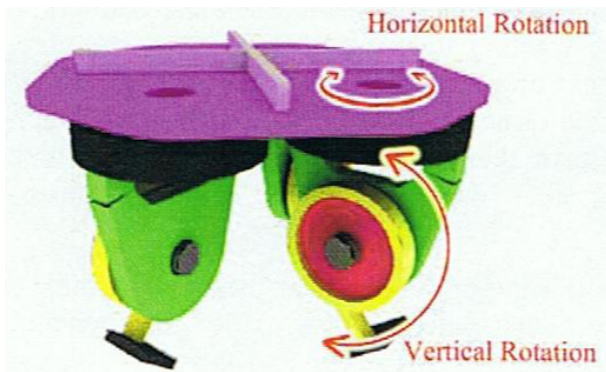


Figure 34. Knot designed and built by Semyung University ^[18]

3.2.7 SeungDeog KIM, SunKyeong PARK, JePil JANG, InA SIN, JangBog LEE, ChangWoo HA and SeungTeak JUNG

SeungDeog KIM, SunKyeong PARK, JePil JANG, InA SIN, JangBog LEE, ChangWoo HA and SeungTeak JUNG ^[19] studied cases of articulations and axis that have been developed previously to deployable structures. They

suggested new joints and axis with hinges from models (Figure 35).

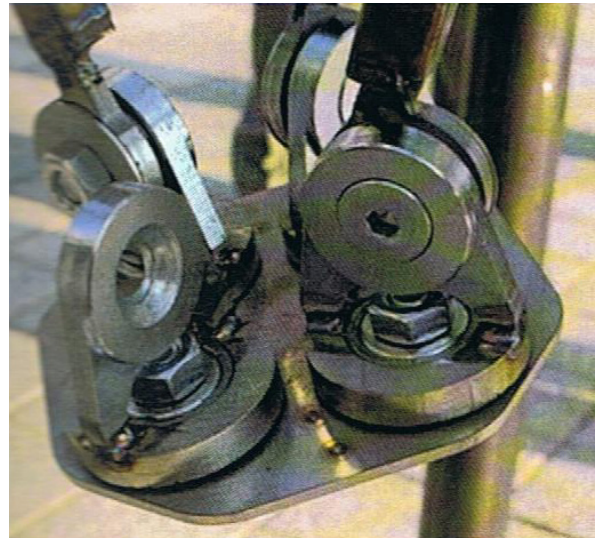


Figure 35. Mockup knot for test model, SeungDeog KIM et al. ^[19]

3.2.8 Yohei Yokosuka and Teruo Matsuzawa

An evolution of the rigid spherical knots is the “multi-joint spherical articulation” of Yohei Yokosuka and Teruo Matsuzawa ^[20]. It is a novel assembled mechanism that permits the tri-axial rotation of the members (Figure 36).

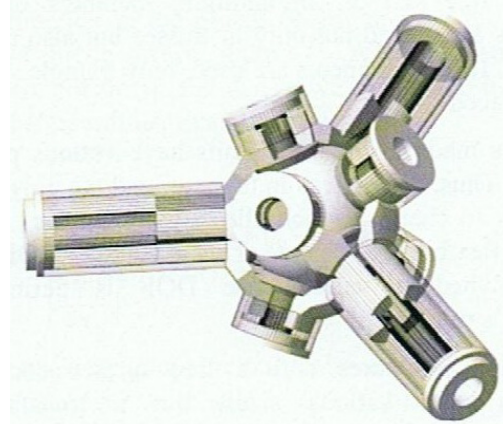


Figure 36. Multi-joint spherical articulation, Yohei Yokosuka and Teruo Matsuzawa ^[20]

3.2.9 Jesús Anaya, M^a Dolores Álvarez and Ramón Serrano

Jesús Anaya, M^a Dolores Álvarez and Ramón Serrano ^[21] developed a node called “Octopus” whose configuration allows it to adapt to all the movement configurations of the lattice structure, from simple solutions for the assembly of a flat structure or more complex solutions that even allow the assembly of curved spatial structures or with different angles, all with a single

connecting piece, considerably reducing the price and standardization compared to current solutions (Figure 37).

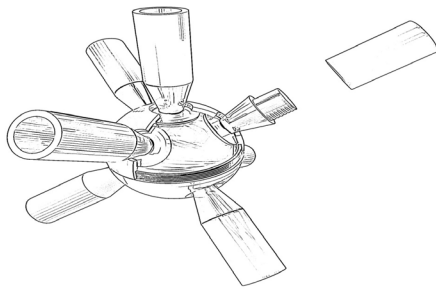


Figure 37. Octopus knot, Jesús Anaya, M^a Dolores Álvarez and Ramón Serrano ^[21]

4. Comparison of Knot Types Used by Transformable and Rigid Linear Structural Systems

In this part a new classification about knots is done. In this classification not only the articulated knots are analyzed, like Rodríguez ^[10] did. Knots types used by transformable and rigid linear structural systems will be analyzed in a same comparison. The classification is represented in Figure 38.

Classification of the knot system	Knot system	Union
Rigid knots structural systems	SDC	Welded
	Pyramitec	Screws
	Tridimatec	Beams in meshes
	Unibat	Board of pyramids and squares
	Spherobot	Hollow sides with screws
	Trio-detic	Bars planes in their ends that are introduced by pressure in serrated grooves that exist in the knots
	Makowski	Pins
	Segmo	Welded
	Tubaccord	Welded or fixed by means of pins
	Bourquardez	Riveting
	Begue	Screws
	Chamayou	Clamps
	Begue-kieffer	Hidraulic group / Slots
	Delacrix-glotin-monier-sejourmet	Rivets Welding / Pins
	Kieffer	Welded
	Sarton	Fixing thread
	Spherical	Welded
	Bi-tubular	Welded
	Tesep	Welded Screwed ribs welded at their ends
	Unistrut	Pins
Mero	Screwed	
Wupperman	Screwed	

Transformable structural systems	Knot of the geodesic dome "Building construction"	Bolt
	Flying Seedpot	Hinges
	Pérez Piñero	Sliding bars
	Preassembled structural framework	Ring to which all the bars reach
	Sliding bar knots (US4026313)	Cross and pivotally
	US4473986A	Bolt
	US 6591849 B1	Pivoting
	Daniel S-H Lee, Olga Popovic Larsen and Seung-Deog Kim	two hinged connections
	SeungDeog KIM, SunKyeong PARK, JePil JANG, InA SIN, JangBog LEE, ChangWoo HA and SeungTeak JUNG	Hinges
	Multi-joint spherical articulation	Assembled
	Octopus	Assembled

Figure 38. Classification of the transformable and rigid linear structural systems knots, own elaboration

Different type of unions appears in different colors in this classification:

Red: knots with screws in their unions, independently if they are rigid or transformable systems.

Blue: knots with welded unions. They are always rigid systems.

Green: other types of unions in rigid systems.

Orange: knots with hinged unions. They are always transformable systems.

Yellow: knots with sliding unions. They are always transformable systems.

Violet: knots with assembled unions. They are always transformable systems.

5. Discussion and Critique of the Analyzed Constructive Systems

As shown in Figure 38, the knot systems can be classified by their unions. This way, we can obtain a series of advantages and disadvantages and utilities of every one of these systems.

Knots with screws in their unions (**red**) can be used in rigid and transformable systems. They are useful for prefabricated structures that can be assembled on site, because they have the advantage that the assembly is easy. The structure can be disassembled, transported and assembled again in another place.

Knots with welded unions (**blue**) are always used in rigid systems. They have the disadvantage that they need skilled labor for welding. When the structure is assembled they cannot be disassembled to assemble again in another place. So, it is a permanent structure.

Other types of unions in rigid systems (green) are assembled by pressure, riveting, clamps... They are economic systems and easy to transport. They can be disassembled, but if it occurs generally we have to replace the union system.

Knots with hinged unions (orange) are always for transformable systems. They really have the same advantages and disadvantages that the screwed unions (red). They are easy to assemble on site, and the structure can be disassembled, transported and assembled again in another place.

Knots with sliding unions (yellow) are always for transformable systems. They have the advantage that they are knots completely prefabricated. The disadvantage is the transport, because they are assembled before being loaded.

Knots with assembled unions (violet) are always for transformable systems. They have the advantage that they can be assembled on site, but the assembly is not easy and they need skilled labor to assemble them.

6. Conclusions

A rigid knot is the type of knot that avoids turns and displacements of the elements; it has a particular and immobile configuration. The articulated and slip knots are the type of knots that permit turns and displacements of the elements. They have a particular and mobile configuration.

Architects and designers have looked for flexible systems where joining the bars in different positions in order to employ the knot for more than one configuration is possible. This way, there is a lot of work to do in order to obtain the appropriate knot to some configurations.

In the investigation, a classification of these types of knot based on their union systems has been done. The advantages and disadvantages are considered. Apart from this, a very exhaustive investigation in materials must be done as future prospect, because materials have to absorb the structural efforts in the most solicited structure parts.

So, it is concluded that there are some patents about rigid, articulated and slip knots, but the investigation has to be continued.

Data Availability

No data, models, or code were generated or used during the study.

Conflict of Interest

There is no conflict of interest.

References

- [1] MediaWiki., 2006. Construction encyclopedia. <http://www.construmatica.com/construpedia>. (Accessed 10 May 2022).
- [2] Motro, R., 2013. Nodes and Structures-A tribute to Stéphane Du Château. (IASS) Symposium 2013 Beyond the limits of man. Wroclaw, Poland. pp. 8. (in English)
- [3] Estrela, C., 2014. The innovative structural conception in Stéphane du Château's work: from metallic trusses to the development of spatial frames. *Architectus*. 4(40), 51-64. (in English)
- [4] Chilton, J., 2000. *Space Grid Structures* (First ed.). Oxford, England: British Library Cataloguing. pp. 1-180.
- [5] Makowski, Z., 2002. Development of jointing systems for modular prefabricated steel space structures. Paper presented at the Proceedings of the international symposium. Warsaw, Poland.
- [6] Fentiman, A.E., 1959. Structural framework. US2931467A (Patent). <https://patents.google.com/patent/US2931467>. (Accessed 10 May 2022)
- [7] Carracedo, J., 2005. Knot for reticular structures. WO 2006097545 A1 (Patent). <https://patents.google.com/patent/WO2006097545A1/es?q=Carracedo%2c+J.%2c+2005.+Patent+WO+2006097545+A1> (Accessed 10 May 2022)
- [8] Vedoya, D.E., Prat, E.S., 2009. Large Span Structures. Technology and design. ITDAH editions. pp. 1-243.
- [9] Nieto, J., 1978. *Synthesis of mechanisms*. AC Publishing, Madrid. pp. 1-206.
- [10] Rodríguez, N., 2005. Design of a structure that can be transformed by deformation of a flat mesh in its application to a quick-assembly shelter. Thesis of Polytechnic University of Catalunya, High Technique School of Architecture of Barcelona, Barcelona. pp. 1-297.
- [11] Fuller, R.B., 1951. Building construction. US 2682235A (Patent). [https://patents.google.com/patent/US2682235A/en?q=Fuller%2c+R.B.+Building+construction.+US+2682235+\(Patent\)+1951](https://patents.google.com/patent/US2682235A/en?q=Fuller%2c+R.B.+Building+construction.+US+2682235+(Patent)+1951). (Accessed 10 May 2022)
- [12] Fuller, R.B., 1953. Flying Seedpot. Geodesic Dome Project, Washington University and Fuller Research Foundation, St. Louis <https://www.bfi.org/about-fuller/resources/everything-i-know/session-11> (Accessed 10 May 2022)
- [13] Pérez, E., 1961. Foldable stereo lattice structure. ES0266801 A1 (Spanish Patent). 3.185.164 (US Patent).

- [14] Moore, A., 1967. Preassembled structural framework. US3325958 (Patent).
- [15] Zeigler, T.R., 1977. Collapsible self-supporting structures. US4026313 (Patent).
- [16] Zeigler, T.R., 1984. Collapsible/expandable structural module with split hub locking. US4473986A (Patent).
- [17] Thomas, R., Swetish, T.R., Baumann, W.R., 2003. Foldable frame structure. US 6591849 B1 (Patent).
- [18] Lee, D.S.H., Popovic, O., Kim, S.D., 2013. Study of the connection joint for scissor-type deployable structure for the possible application in emergency evacuation shelter. New proposals for transformable architecture, engineering and design. Ed. STARBOOKS Structural Architecture. pp. 105-109.
- [19] Kim, S.D., D., Park, S.K., Jang, J.P., et al., 2013. A Study on Deployable Shelters Considering Biaxial Rotations of Joints. New proposals for transformable architecture, engineering and design. Ed. STARBOOKS Structural Architecture. pp. 111-114.
- [20] Yokosuka, Y., Matsuzawa, T., 2013. Shape-finding Analysis for Variable Geometry Structures Formed by a Multilink Spherical Joint. New proposals for transformable architecture, engineering and design. Ed. STARBOOKS Structural Architecture. pp. 83-88.
- [21] Anaya, J., Álvarez, M.D., Serrano, R., 2020. Union system for mobile reticular structures. ES 1238524 Y (presented Spanish patent). U. 201931716 (8) (utility Spanish model).