

ARTICLE

Bulk Raw Materials Handling and Blending Techniques of Sinter Plant: A Case Study of Ajaokuta Steel Company Limited, Kogi State, Nigeria

Cyril Ocheri^{1*} Hebert. A. Obiorah¹ Romanus Egwuonwu Njoku¹ Nnaemeka Anthony Urama¹ Joseph Babalola Agboola² Christopher Nwankwo Mbah³ Johnson Nwaemezie Ezeanyanwu³ Chikezie Walter Onyia³

1. Department. of Metallurgical and Materials Engineering, University of Nigeria, Nsukka
2. Department of Metallurgical and Materials Engineering, Federal University of Technology, Minna, Niger State
3. Department of Metallurgical and Materials Engineering, Enugu State University of Science and Technology, Enugu

ARTICLE INFO

Article history

Received: 21 September 2019

Accepted: 29 October 2019

Published Online: 30 November 2020

Keywords:

Blast furnace
Iron concentrate
Sinter Plant
Stockpile
Stockyard facilities

ABSTRACT

Bulk raw materials handling plant and sintering plant preparatory plants are established to receive, blend, stockpile, prepare and supply specified grades of raw materials for smooth operations of iron making plant (Blast furnace), steel making plant (Basic oxygen converter) and lime Plant(calcinations plant). The study discusses bulk raw materials handling and some general problem of scientific analysis and documentation of basic equipment details, stockyard facilities, bulk materials transport systems and sinter processes, for the general knowledge and operational procedures of these plant for effective and efficient operational processes for optimal results. Iron ore concentrate supplied from the mines to some extent fluctuate in their chemical composition as a result of the nature of the deposit with various factors controlling beneficiation processes and addition of metal-bearing materials collected as a waste product from the Rolling Mills, Blast Furnace and Sinter Plant which must be recycled through Iron ore concentrate stockyard. The part of the sinter mixture is melted at a temperature about 1300-1480 ° C and a sequence of reactions shaping the sinter cake to be loaded into the blast furnace to produce iron from a pig.

1. Introduction

Bulk raw materials handling plant and sintering plant preparatory plants are established to receive, blend, stockpile, prepare and supply specified grades of raw materials for smooth operations of iron making plant (Blast furnace), steel making plant(Basic

oxygen converter) and lime plant(calcinations plant). Moreover, the decision by the Federal Government to embark on this gigantic project in 1979 at the time the world oil market was facing uncertainties was informed not only by the to diversify the sources of foreign exchange but because of the catalytic effect of the steel industry in the development of the real sector of the economy. This

**Corresponding Author:*

Cyril Ocheri,

Department. of Metallurgical and Materials Engineering, University of Nigeria, Nsukka;

Email: cyril.ocheri@unn.edu.ng

includes amongst others, the utilization of local raw materials (which a bound in large quantities in the country yet untapped) to a high degree in the production process, encourage and setting up of steel-related down-stream and auxiliary industries, inculcation of adaptive technology culture in Nigeria and provision of strong research and development base for the technological take-off of the country. In fact, Ajaokuta steel company is the first company of this magnitude in Nigeria to have a high input level of Nigerians in the project conception and management.

The Ajaokuta steel company is planned to produce 1.3million tonnes of liquid steel per annum in the first phase to be finished in too long products as; 130,000 tons of wire rods, 400,000 tons of long products and light structures, 560,000 tons of rails and medium structures. This is to be upgraded to 2.6million metric tonnes in the second phase. The steel plant is designed to reach an ultimate capacity of 5.6million metric tonnes per year for long and flat sheet products including various sizes of heavy, medium and light structural sections, rails, plates, pipes and thin sheets. The integrated plant is one of the comprehensive steel plants in the world. It is unique in the completeness and spread of its integration. It comprises several full-fledged auxiliary, support and service industries all in one location. Some of these are; (1)A captive thermal power plant of 110 MW capacity, (2)A 7,000 tons capacity integrated foundry, (3) A massive Aluminosilicate plant, the largest in sub-Sahara (Africa), (4) A coke-oven and by-product chemical plant, (5)An oxygen separation plant, (6)A lime calcinations plant, (7)A rubberizing plant, (8)Four independent Rolling Mills, (9)A 795,000 tons capacity Billet mill - the only one in Nigeria and (10)An integrated mechanical repair shop complex.

In Ajaokuta, the technology adopted is the time tested conventional Blast furnace and Basic oxygen furnace (for Iron and steel making processes), suitable for making high tonnage steel. The development strategy for the steel plant was based on a “backwards integration” approach.

This entailed the construction and completion of the final process stages first followed by the construction of the primary production plant. The backwards integration approach adopted was to allow the units already completed and which can stand alone as viable enterprises to generate revenue for the completion of the primary plants. The analysis of sourcing, handling, blending and preparation Of the basic raw materials to be administered to these primary operations of Iron and steel making processes are the main aims and objective of this project.

The systematic addition and blending of these materials to achieve a homogenous stockpile of Iron ore concentrate with a variety of chemical compositions throughout the

stockpile not exceeding 0.5% is yet another major reason why this research work was studied. Other problems often encountered by engineers in the field in maintaining relatively sTable sinter basicity (Lime / Silica ratio), this was also the reason for discussing the basic steps involved in Sinter charge calculations.

2. Raw Materials Requirements of Iron and Steelmaking

The raw materials requirement of Iron and steel making processes for Ajaokuta Steel Company Limited (ASCL) comprises of the following: (1) Iron ore concentrate, (2) Coking coal, (3) High-grade Iron ore lumps, (4) Fluxes(Limestone and Dolomite), (5) Bauxite, (6) Manganese ore and (7) Ferrous scrap. The annual consumption of the various raw materials and their possible sources are shown in Table 1 below:

Table 1. Raw material input of ASCL

S/No	TYPE OF RAW MATERIALS	SOURCES	ANNUAL REQUIREMENT (TONNES)
1.	Iron ore concentrate	Itakpe (Kogi State)	2,171,000
2.	High-grade Iron ore lumps	Imported	55,000
3.	Coking coal	Imported	1,300,000
4.	Limestone	Jakarta / Mfamosing	694,000
5.	Dolomite	Osara / Burum	265,000
6.	Manganese ore	Imported	84,000
7.	Bauxite	Imported	13,000
8.	Ferrous metal scrap	Local	120,000

2.1 Sourcing of Limestone

For the purpose of this project, only sourcing of limestone being the major fluxing agent in Iron and steel making process will be discussed in detail. Investigations on the suitability of Mfamosing limestone deposit for converter grade limestone was initiated in early October 1977 ^[1]. This was done because the available limestone deposit at Jakura, though chemically suitable for converter lime, is mechanically unfit for conventional L.D converter steel-making process. Furthermore, it was envisaged that a total of about 680,000 tonnes of limestone per annum would be required for the various processes in the steel complex out of which 240,000 tons per annum of the high-quality limestone would be needed for the steelmaking operations ^[1].

2.1.1 Geology of the Mfamosing Deposit

The Mfamosing deposit is located 30km northeast of Calabar city in the Cross-River State of Nigeria. The distance between this location and Ajaokuta is approximately 600km by road. The deposit is sedimentary in origin,

occurring in marginal basin deposits of Cretaceous age (About 100 mil. Years old) overlying the Precambrian basement and consist in well-developed algae, or lithic and detritus facies which related to a reef and classic environment deposits^[2]. The reef variety is white in colour while the classic variety is grey. Only the white variety of the deposit satisfies the requirement for converter lime manufacture. For a cross-section of the deposit see Figure 1 below:

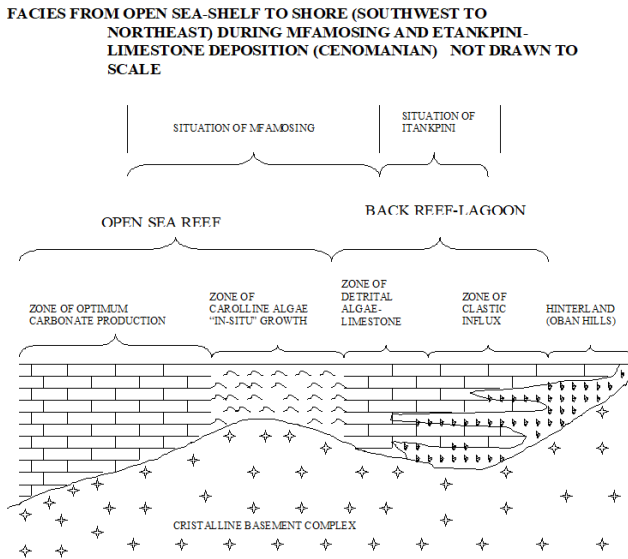

Figure 1. Idealised Stratigraphic Model Showing Variation In the exploitation of the Deposit

2.1.2 Exploitation of the Deposit

The total overburden to be stripped for quarrying operations is estimated to be 6.72 million tonnes and the estimated exploitable reserve is 18 million tonnes. They are known on the surface of 0.7 km² and mined on 0.25km². Based on the geological information of the deposit, it is evident that selective mining will be absolutely necessary since not all the deposit is suitable for the high-quality limestone required for the steel production.

2.1.3 Chemical and Physical Analysis of Mfamosing Limestone

Generally, lime is the basic slag forming component of the total charge in L.D. converters for steel making. For this purpose, very stringent high-quality lime is a basic pre-requisite for the converter lime. Table 2 below compares the properties of Mfamosing lime with Jakura and the standard established in the Detailed Project Report^[1]. It clearly indicates that the Mfamosing is very suitable for the converter lime. It has also been recorded that the

limestone yields over 70% of fines below 10mm and just 10% of the acceptable lumps after calcinations.

Table 2. Chemical Analysis of Limestone from Jakura and Mfamosing^[1]

S/No	Element (%)	DPR (%)		Jakarta (%)		Mfamosing (%)	
		Sinter & B/ Furnace	Converter	Grey	White	Grey	White
1	CaO	53 min.	53.5 min.	52.28	54.7	54.5	55.04
2	MgO	0.64 max.	1.2 max.	1.14	0.41	0.58	0.24
3	SiO ₂	1.81 max.	1.0 max.	2.6	0.23	5.07	0.69
4	S	0.052 max	0.05 max.	0.14	0.05	0.18	0.04
5	P	0.01 max.	0.06 max.	0.12	0.03	0.04	0.01
6	Al ₂ O ₃	0.31 max.	1.5 max.	1.75	0.61	1.6	0.37
7	L.O.I.	43.76	43.76	40.2	43.76	40.2	43.74
8	Fe ₂ O ₃	0.21 max.	1.5 max.	1.3	0.19	1.2	0.2
9	P ₂ O ₅	0.21 max.	0.03 max.	0.07	0.05	0.02	0.02
10	SO ₃	0.13 max.	0.13 max.	0.23	0.21	0.09	0.11
11	TiO ₂	0.02 max	0.02 max	0.05	0.04	0.01	0.02
12	ALKA-LI	0.09 max.	0.09 max.	0.15	0.14	0.06	0.08

In terms of CaO and SiO₂ values, the above Table II indicates that whilst all the three limestones are suitable for sinter making and Blast furnace additions, only the white varieties of Jakura and Mfamosing are suitable for steel making.

2.2 Sourcing Dolomite

The major sources of dolomite to the integrated steel plant for control of Sinter basicity and production of dolomite refractory bricks are the Osara and Burum deposits. However, the Osara deposit is accorded top priority after a semi- Industrial test on the deposit was carried out at the all-union refractory Institute, Leningrad (USSR). The chemical and physical analysis conformed to the standard specification in the Detailed Project Report^[1] as indicated in Table 3 below:

Table 3. Chemical Analysis of Osara Dolomite Deposit

S/No	Element	DPR (%)	Osara Deposit (%)
1.	L.O.I.	35.00	33.11
2.	SiO ₂	6.38	13.10
3.	Al ₂ O ₃	0.30	0.27
4.	Fe ₂ O ₃	3.00 max.	2.52
5.	CaO	30.00 min.	35.89
6.	MgO	15.00 min.	14.82
7.	K ₂ O	0.02 min.	trace
8.	NaO	0.20 max.	0.16
9.	MnO	0.10 max.	0.06
Total		100 %	99.93 %

3. Sourcing of Bulk Materials for the production of Sinter

3.1 Sourcing of Iron Ore Concentrates

The source of this raw material is the National Iron Ore Mining Company (NIOMCO) at Itakpe in Kogi State. The chemical analysis of this important raw material required by the DPR is as shown in Table 4 below:

Table 4. Chemical Analysis of Iron Ore Concentrate for NIOMP & DPR ^[3]

S/No.	Element	DPR %	NIOCOM(Itakpe) %
1.	Fe	63.00	65.60
2.	Al ₂ O ₃	0.80	1.02
3.	SiO ₂	0.80	5.14
4.	P ₂ O ₅	0.07	-----
5.	P	0.03	0.055
6.	S	0.014	0.015
7.	Mn	0.08	0.06
8.	CaO	0.40	0.30
9.	MgO	0.20	0.18
10.	TiO ₂	0.17	0.12
11.	Na ₂ O +K ₂ O	0.15	0.17
12.	Zn(ppm)	---	traces

3.2 Sourcing of Coking Coal

Good quality metallurgical coal is not available in Nigeria in economic quantity, therefore, the total quantity of metallurgical coal is to be imported. In order to minimize the import, coal carbonization tests have been conducted to determine the suitable coal blends and the extent indigenous coal that can be used to blend the imported coals. EBE of Germany after conducting the necessary tests have concluded that Indigenous Enugu coal is to be crushed to 100 per cent below 0.1mm. Other blends have also been recommended to consist of 100 per cent of imported coals. The test report has been accepted by V/O Tiajpromexport (TPE) and it was decided to use 100 per cent imported coal blend during the commissioning of the plant and up to guarantee test period. To improve the economics of ASCL, it will be prudent to maximize the use of indigenous coal in the blend by adopting suitable technologies such as partial briquetting of coal etc.

The ranges of variations of chemical analysis in metallurgical cokes are given in Table 5 below:

Table 5: Proximate Analysis of Metallurgical Cokes

S/No.	Elements	Range
1.	Fixed carbon	83-90 %
2.	Volatile matter	0.5-4 % (preferable < 2 %).
3.	Ash.	4-15 % (preferable < 10 %).
4.	Moisture.	< 5 % (preferable < 3 %).
5.	Sulfur.	0.5-3 % (preferable < 1 %).
6.	Phosphorous	< 0.04 %

4. Raw Materials Off-Loading Facilities

The whole plant layout covering materials handling and sintering plant which this project is project is based upon is shown in Figure 2 below:

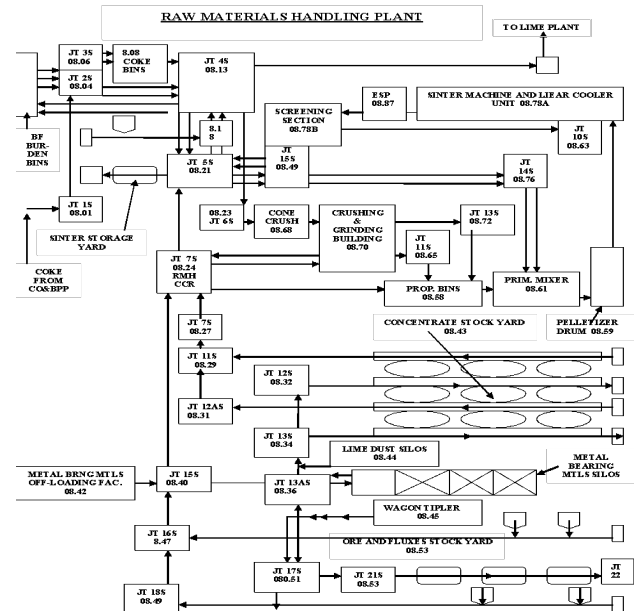

Figure 2. Layout of Sintering Plant

This unit was charged with the responsibility of receiving, blending, stockpiling and dispatching to the Sintering plant, Blast furnace, Lime plant and Steelmaking shop according to laid down procedure. To perform this responsibility efficiently and effectively, the unit comprises the following sections: (1) Off-loading facilities, (2) Fluxes stockyard. (3) Metal bearing materials stock bins. (4) Iron ore concentrate stockyard. (5) Aspiration plants (Dust cleaning plants) and (6) Network of inter-departmental conveyor belts.

4.1 Fluxes Off-Loading Facilities

Fluxes are delivered to the steel plant by two conventional methods of haulage viz; Railway and Road, therefore an elaborate arrangement has been put in place to receive the fluxes by both bottom discharge locomotive wagons and tipping trailers. In each case, the fluxes are discharged into underground bunkers 6Nos. in each arrangement with a combined volume 68m³. In any of the arrangement, the fluxes are off-loaded and fed into a common 1400mm width conveyor belt by means of Belt feeders for onward delivery to fluxes stockyard. The load-carrying capacity of the conveyor belt is 1500 tons per hour.

4.2 Coking Coal Off-Loading Facilities

Because of the high tonnage requirement of coking coal

for production of coke in the coke-oven plant, it was envisaged that only rail transport system could cope with the annual requirement of 1,386,000 tonnes of coal per annum. As a result, the off-loading facility for coal was designed to receive the coking coal by means of only bottom discharge wagons into 6 numbers underground bunkers of the combined volume of 68m³. By means of belt feeders, the discharged coals are fed into 1000 tonnes/hour conveyor belt, which is expected to deliver at the spacious coal stockyard via a rail-mounted stacker machine and later dispatch to coke-oven proportioning bins by means of a reclaiming machine on request by the user shop. A schematic diagram of the rail-mounted traversing stacker machine is shown in Figure 6 below. The area of one stockyard is 460m x 26m with an average bulk height (Stocking height) of 2.5m and a volume of 29,900m³. The storage capacity of one stockyard is 30,000 tonnes of coking coal, there are four stockyards of similar dimension, which give a total storage capacity of 120,000 tonnes. This corresponds to 3 weeks of continuous operation stock to coke-oven. The stockyard is also equipped with 3 numbers of Stackers with the capacity of 1,500 tonnes per hour each and 3 numbers of Reclaimer with the capacity of 1,300 tonnes per hour each. The off-loading facility building has a height of +18.035m and - 19.3m deep (i.e. from level ground surface), this building housed all the receiving underground bunkers and conveyor belt delivery tunnels.

4.3 Metal Bearing Materials Off-Loading Facilities

Metal bearing materials are waste products of rolling mills, Blast furnace, Lime calcinations plant and Sintering plant processes which otherwise would have passed for waste but with this blending techniques developed they can now be recycled back into the process line. The arrangement provided in raw materials handling unit to receive, off-load and stockpile metal-bearing materials either by tipping trucks or by pneumatic tankers as the case may be. The type of metal-bearing waste and their estimated quantities are listed below:

- (1) Scales from the Rolling Mills = 37,000 t/yr.
- (2) Lime screening from the Lime Plant = 10,000 t/yr.
- (3) Flue dust from the Blast furnace = 18,000 t/yr.
- (4) Sinter screenings from sintering plant = 170,000 t/yr.

Items (1), (2) and (4) above are received by tipping trucks while item (3) is received by pneumatically powered off-loading tanker trucks.

4.4 Iron Ore Concentrate Off-Loading Facility

The concentrate was received from National Iron Ore

Mining Company (NIOMCO) by rail wagons of 60 to 70 tons carrying capacity into ASCL's marshalling yard where NIOMCO's locomotive engine de-coupled and coupled with trains of pre-arranged empty wagons back to NIOMCO's loading yard for another circle. The circle time was determined to be 3hrs 22mins. ASCL's shunting locomotive engine was coupled to the concentrate consignment from marshalling yard and move the loaded wagons through the intricate network of rail lines until it is carefully positioned on the wagon tippler's discharging track. The shunting locomotive engine was de-coupled and re-coupled to the previously discharged empty wagons back to marshalling yard for onward transfer back to NIOMCO. This is the main function of ASCL's internal shunting locomotive engines. The positioned, loaded wagons on wagon tippler's track are coupled with an electrically remotely controlled wagon-pusher (or car pusher) see Appendix V via a pushing flat form attached with the pusher. The car pusher has a tested pushing capacity of 160 KN, with this pushing force it can push 25 wagons loaded with 60-70 tonnes of concentrate, with a forward speed of 0.5m/sec and 1.0m/sec while empty.

The car pusher itself has a total weight of 70 tonnes. Its function is only to push fully loaded wagons serially and carefully position one wagon at a time on the centre of wagon tippler's plat-form (cradle). This was done by the operator from his operating cabin (pulpit) with the help of wagons attendant on the shop floor, and perform the function of supervising the centring operations, coupling and decoupling of wagons before and after each tipping circle. Massive rotating structure measuring 17470mm x 9639mm x 9038mm equipped with a well-balanced platform that accommodates loaded wagons ready for off-loading. The plat-form (cradle) was overlain with a railway track properly aligned with the surface railway track when in normal idle position but it rotates with the tippler when off-loading independently from the surface railway track. During tipping operation, the rotor rotates through an angle of 175°. At this tilt angle, the materials are off-loaded into an underground bunker by means of gravity and a vibrator to ensure all content of the wagons are completely emptied, after which the tippler return back to its normal position by reversing the tipping action ready for another circle of operation.

This rotation is accomplished by employing the principle electro-dynamic braking system where alternating current and direct currents are charged to the system alternately at various pre-determined angular stages of the 175° rotation. At the dead-end of 175°, the whole power supply is cut-off, this action instantly set the electro-hydraulic braking system on. It was timed to remain in this

position for a period of about 15 seconds during which vibrator must have stopped and all content of wagon emptied. The whole process of the rotation was then reversed to its initial take-off position and circle takes 63 seconds to complete.

The underground bunker has a capacity of 180 tonnes of concentrate, it is equipped with apron-feeder below the bunker, which feeds concentrate continuously into the network of conveyor belts of 1000 tonnes capacity through chutes at each transfer points from underground to surface concentrate stockyard. The Wagon tippler building has a height of +18.035m and -19.30m from the ground surface.

5. Theoretical Analysis

5.1 Stockyards Ore and Fluxes Stockyard

Raw materials received by ore and fluxes off-loading facilities are discharged into ore and fluxes stockyard by means distributing car positioned on a gallery elevated at 22m above the stockyard ground level and it is mounted on a rail with electric drives that enable it traverses the whole length of the stockyard which is 566.2m. The distributing car ensures stockpiling of ore and fluxes at pre-determined spaces earmarked for each type of ore and fluxes. The overall area of the stockyard is $566.2\text{m} \times 94\text{m} = 53222.8\text{m}^2$, with this surface area, the stockyard can store up to 30 days stock of the following materials:

- (1) Limestone = 58,400 tonnes
- (2) Dolomite = 24,460 tonnes and 90 days (3 months) stock of
- (3) Bauxite = 3,250 tonnes
- (4) High grade Iron ore lumps = 14,000 tonnes.

The stockyard is equipped with two giant pay-loaders of KOMATSU make; each has a 5m^3 -bucket capacity charged with the responsibility of dispatching ore and fluxes to the user shops as directed by dispatcher stationed at the central control room. The stockyard is also equipped with 1,300 t/hr conveyor belt at both sides used for dispatching the fluxes to the user shops. A cross-section of various stockpiles of ore and fluxes and the dimensions of the area they occupy is shown in.

5.2 Iron Ore Concentrate Stockyard

Iron ore concentrate received by wagon tippler is stored in this stockyard by means of a Stacker machine shown in figure 6. The whole stockyard consists of 3 bays and in each bay, there are 4 stockpiles, each stockpile has the following dimensions:



Figure 6. Stacker and Reclaimer Machines with Stock Pile of Iron Ore Concentrate

Length = 92,000mm

Width = 30,000mm

Height = 13,500mm

Volume = $37,260\text{m}^3$

Period of stock = 30 days.

Tonnage of stockpile = 93,150 tonnes.

The number of stockpiles in a bay = 4 stockpiles.

Total No. of stockpiles $3 \times 4 = 12$ piles.

Total tonnage capacity of the whole stockyard = 1,117,800 tons.

Effective volume of stockyard = $447,120\text{m}^3$.

Specific bulk weight (density) of Conc. = 2.5 t/m^3

Details of the stockyard arrangement are shown in the general layout diagram of Appendix IV above.

5.3 Stockpile Building - Process Techniques

There are three widely known methods of building stockpiles of Iron ore concentrate viz; Chevron layering, Wind brow layering (parallel pile), and Coil layering^[4]. The decision to apply any of the three methods entirely depends on the chemical and physical characteristics of the raw material being stockpiled. During this project work, the chemical and physical properties of the beneficiated Iron ore concentrate from Itakpe was carefully studied and analyzed, chevron system of stockpiling is hereby recommended for use in ASCL's concentrate stockyard, this is because the concentrate received from the beneficiating plant of NIOMCO has a particle size range from 0 to 1mm and it has a relatively uniform chemical composition. Chevron method is suitable for this class of material since there are no large lumps to give rise to size segregation at base of stockpile because of gravity differential during stockpiling operation. For this reason, the chevron method of stacking will be discussed in detail with a view

to implementation when full operation commences. Other methods too will be discussed briefly.



Figure 7. Stacker Machine

5.3.1 Chevron Layering

This method consists of traversing the stacker arranged to feed the centre of the bed being formed. On the first pass, a triangular section of the material was deposited along the length of the stockyard. Let us consider the stacker having a stocking-out capacity of 1,500 t/hr and an average traversing speed of 25 meters per minute. The angle of repose of Iron ore concentrate is 35° . On the first pass, a triangular section pile was deposited along the length of the stockyard having a width of 1125mm and a vertical height of 375mm. On the second pass, a thickness of 150mm was added to the top of the first pass (pile). As bedding proceeds, the thickness of the layers is theoretically decreasing to only a few mm. The main disadvantage of this method is that segregation of materials occurs where lumpy materials constitute parts of the feed, resulting in the larger materials tending to be deposited in bands at the bottom and outside edges of the pile. In some instances, depending on the method of blending and reclaiming employed, this does not give the correct beneficiation required to the final burden. In the case of ASCL, at least for the nearest future, it is an only fine concentrate (0-1mm) was expected to be bedded. Chevron layering is, therefore, most suitable, providing a finished pile that is practically homogeneous in its size distribution and chemical composition.

5.3.2 Wind Brow (Parallel Pile) Layering

This method consists of laying a series of parallel piles by slewing the stacker at the end of each long travel circuit down the stockyard. When the first pile has been laid over

the full base area of the bedding yard, the second tier of the piles is formed by filling in the furrows left between the piles. In this manner, a flat-topped pile can be formed if so desired depending on the base, width and height of the pile.



Figure 8. Reclaimer Machine with Iron Ore Concentrate Stockpile

The advantage of this system is that it avoids segregation, the disposition of the lumpy materials of each pass being restricted to the confines of its own smaller triangular pile as an integral part of the whole bed. An examination of a pile bedded in this manner clearly indicates a pre-determined cross-section blend with the lumpy materials deposited consistently throughout the completely homogeneous mass.

5.3.3 Coil Layering

This is a system similar to that described above, but with added refinement on the stacker control equipment. This would entail a form of Pantograph system or similar method so that the control gear would be coupled to a profile model of the refined file being laid. Bedding would begin at the side of the stockpile remote from the stacker, and the machine would traverse.

The full length of the stockpile. At the end of the yard, the stacker would be arranged to slew round to form the end of the pile before returning along the yard on the edge of the pile nearest the stacker. At the opposite end of the yard, the stacker would automatically slew to form the other end of the pile and on the second complete circuit. A coil layer would be formed within the periphery of the first. Layering would continue until the whole of the bedding area was covered with triangular piles, each representing one pass of the Stacker. Now, the Stacker would be elevated to form the second tier by filling the furrows left between the initial base piles. This process would con-

tinue with the coils becoming progressively smaller until the desired height of stockpile had been formed. The additional advantage of this system over parallel pile layering is that it spreads the materials more evenly throughout the width and length of the bed. Although such an automatic system has not been installed to date, as far as we know, due to the high initial capital cost of control gears and the general lack of development in this direction, this method could well be the answer to the age-old enemy of bedding segregation.

5.3.4 Determination of Stacker Traverse Speeds

It will be readily appreciated that in order to attain efficient bedding it is necessary to achieve a constant rate of stocking of materials irrespective of the direction of travel of the equipment along the stockyard. Obviously, if the stacker travels at the same speed in the forward and reverses direction, due to the decreasing length of the material-carrying section of the main stocking-out belt.



Figure 9. Stacker and Reclaimer Machines with Stock Pile of Iron Ore Concentrate

Thus in order to attain a constant rate of stocking-out, we have two separate conditions. During forward motion of the Stacker, the amount of materials laid equals the relative velocity of the materials discharged multiplied by the weight of material per meter of the belt. During the reverse motion of the Stacker, the amount of material laid equals the relative velocity of the material discharge multiplied by the time to traverse the length of stock-yard in the reverse direction, multiplied by the weight of material per meter of the belt.

Let W = Rate of materials flow tons/min.

V = Velocity of stockyard belt, m/min.

V_f = Traversing velocity of Stacker in the forward direction, m/min.

V_r = Traversing velocity in the reverse direction, m/min.

L = Distance traversed by Stacker in each direc-

tion.

Therefore, the following can be deduced:

(1) During forwarding direction, the relative velocity of material discharge = $V - V_f$

(2) During the reverse direction, the relative velocity of material discharge = $V - V_r$

(3) Time to traverse the length of stockyard in forwarding direction = L / V_f

(4) Time to traverse the length of stockyard in reverse direction = L / V_r

Then,

The amount of material laid in forward direction =

$$(V - V_f) \cdot \frac{L}{V_f} \cdot W / V$$

The amount of material laid in reverse direction =

$$(V + V_f) \cdot \frac{L}{V_f} \cdot W / V$$

These rates are to be equal,

$$(V - V_f) \cdot \frac{L}{V_f} \cdot \frac{W}{V} = (V + V_r) \cdot \frac{L}{V_r} \cdot \frac{W}{V}$$

L , W and V are equal in both sides, then the equation reduces to

$$\frac{(V - V_f)}{V_f} = \frac{(V + V_r)}{V_r}$$

$$\left(\frac{V}{V_f}\right) - 1 = \left(\frac{V}{V_r}\right) + 1 \text{----- equation 1}$$

$$V / V_f - 2 = (V / V_r)$$

$$V / V_r = (V - 2V_f) / V_f$$

$$\left(\frac{V}{V_r}\right) = \left(\frac{V - 2V_f}{V_f}\right)$$

$$V_r(V - 2V_f) = V \cdot V_f$$

$$V_r = V \cdot \frac{V_f}{V - 2V_f} = \text{Reverse Velocity----- equation (ii)}$$

From equation (i) above

$$\frac{V}{V_f} = \left(\frac{V}{V_r} \right) + 2$$

$$\left(\frac{V}{V_f} \right) - 1 = \left(\frac{V + 2V_r}{V_r} \right)$$

$$V_f (V + 2V_r) = V \cdot V_r$$

$$V_f = \left(\frac{V \cdot V_r}{V + 2V_r} \right) = \text{Forward Velocity} \text{----- equation iii}$$

Although the traversing velocities of Stacker are not directly proportional to the speed of the main stocking out belt, V_f must be less than V , Otherwise, no material can be deposited over the Stacker's head in the forward direction. Examination of equation (ii) will show that V_f approaches $\frac{v}{2}$, V_r approaches infinity, and in practice, V_f is always considerably less than $\frac{v}{2}$ as previously pointed out, V_r will always be faster than V_f and generally practical considerations will fix the value of V_r at a maximum, thus allowing V_f to be determined from equation (iii).

6. Determination of Stacker Capacities

Since the time taken to travel along the stockyard in the forward direction is greater than that taken to travel in the reverse direction, and since the amount of material deposited in both direction must be the same, then obviously the rate of material flow over the boom conveyor under these conditions must be different. The following expressions will give the actual rates during forward and reverse traversing of the boom stacker. The rate of flow over the boom conveyor in the forward direction equals the rate of flow along the stockyard belt minus the weight of materials per meter of stockyard belt, multiplied by the traversing velocity of the Stacker. We have, therefore:

Rate of flow of material over boom conveyor in the forward direction

$$W - (W \cdot V_f / V)$$

This expression can be re-written as

$$\left[\left(V - \frac{V_f}{V} \right) \right]$$

$$\left(\left(V - \frac{V_f}{V} \right) \right] \cdot W \text{ tonnes /min}$$

Rate of material flow over the boom conveyor in the reverse direction equals the rate of material flow along the stockyard belt plus weight of material per foot of stockyard belt multiplied by the traversing velocity of the stacker. We have therefore the rate of material flow over boom conveyor in the reverse direction: $W + (W + V_r/V)$. This expression can be re-written as $\left[\left(V + \frac{V_r}{V} \right) \right] W \text{ tonnes /min}$.

Number of passes: - The number of passes in producing a pile influences the efficiency of blending a great deal. It is given by $N = (W \cdot V \cdot 60) / (C \cdot L)$

Where N = Number of layers or passes.

W = Pile capacity, tons.

V = Average Stacker traversing velocity, m/min.

C = Main stocking belt capacity in tons/hour.

L = Length of the stockyard.

7. Sintering Plant

The purpose of sintering process is to prepare high-quality feedstock for the Blast furnace from Itakpe Iron ore concentrate, manganese ore, Blast furnace flue dust, mill scale and other Iron bearing materials by sintering them with the corresponding amount of limestone and dolomite with coke breeze used as solid fuel. The heart of a sintering plant work is the production of sinter cake. In accordance with the requirement of a Blast furnace process, good sinter should have: (1) Constant content of Iron manganese and Iron monoxide with minimum deviation from basic ones; (2) Constant (with minimum deviation from basic ones), basicity that is calcium dioxide-to-silicon dioxide ratio; (3) Minimum sulfur content; (4) High mechanical strength; (5) Minimum content of fines (fraction 0-5mm) when being charged into the blast furnace.

Getting uniformity with respect to maximum temperature. The distribution of heat ensures homogeneous sintering, refining, Efficiency and synthetic efficiency. Sintering of a double layer is Performed in some plants to achieve this goal (realization of Homogenous Tmax in its entire sinter bed thickness), and it consists of the preparation of the upper coke layer Contenu in the bottom to stop the ten^[23]. When sintering is achieved at lower temperatures than 1300 ° C, decreases magnetite formation (less FeO) and improves the RI and the Degradability Index (RDI)-RDI. In addition, the optimal structure for reducibility of sinters Attainment of hematite nuclei (un-melted) in the blast furnace Surrounded by a network of acicular ferrites^[33].

In modern plants, infrared thermography is used to Track the burn-through sintering point (when the flame occurs) The front approaches the base of the bed, but also for predicting Sinter characteristics and solid fuel rate

change (adjusting the solid fuel rate) Amount of coke in a blend)^[32]. Simulation models for sintering have been used to research the Method variables^[30,31], so that the equations for heat distribution could be achieved^[18]. The conduct of crude blends with a high content of goethite ore in the structure and permeability of sinter beds were examined. Japanese steel mills since the 1980s^[24,26]. Sintering is a method of thermal agglomeration (1300-1480°C,^[29] of a blend of mineral fines from iron ore (0.5 to 8 mm), iron and steel production by-products, Fluxes, elements forming slag, and fossil (coke) fuel. The target method by which the mixture of charged materials is mixed partly fused to create clustered clusters at a high temperature, the load (12-35 mm) for the blast furnace is received. The required physical-chemical and lowest mechanical characteristics^[26]. On the opposite, incineration occurs as a horizontal layer. This passes across the bed vertically. The density of this A small fraction of the bed is a layer. Permeability is an output Load requirement, and for that reason the granulation Method is used beforehand (permeability enhanced during^[22]. The sintering process is dependent on an increase in the temperature of Rough mix with a view to partial melting and Creation of a molten metal that crystallizes during refrigeration. In many mineral phases that agglomerate or solidify The system. The coke burning provides the energy for^[27,28]. Sinter is stronger at softening and melting than pellets and ore, but worse at meltdown and high-temperature gas resistance, resulting in a 65 per cent mixed burden Sinter, 20 per cent lump ores, and 15 per cent pellet Best Outcome^[34].

8. Raw Materials Requirement for Sinter Production

The raw material consumption data for the production of high-quality sinter are shown in Table V below; Sinter burden consists essentially of Iron ore concentrate, metal-containing waste, manganese sinter ore, lime screening, limestone, dolomite, sintering recycles and solid fuel fine (coke breeze).

Table 6. Raw Material Requirement for Sinter Production

S/No.	Type Of Raw Material	Consumption (tons/year)	Size Range(mm)	Moisture Content (%)
1.	Iron ore concentrate	2,135,000	0-1	6
2.	Mill scale	40,000	0-1	6
3.	Blast furnace flue dust	18,000	0-1	8
4.	Manganese	85,000	0-8	10
5.	Sludge	205,000	-	6
6.	Lime dust	58,000	-	-
7.	Limestone	300,000	0-80	2
8.	Dolomite	240,000	0-80	2
9.	Sinter return	1,543,000	0-5	-
10.	Coke	240,000	0-30	4

8.1 The Sinter Machine

The sintering machine installed at Ajaokuta consists of an endless pallets chain and is provided with gear-shaped sprockets for lifting and lowering the pallets at the load and discharge ends respectively in figure 9 above. The foot-shaped guide rails for the lifting and lowering stations are normally designed in such a way that the pallets are separated by both segments and pass from the upper strand to the lower strand without the pallets coming into contact with each other and without being subjected to too much wear. Cross-section of the sinter machine is shown in figure 10.

Major accessories of the sinter machine include;

- (1) The ignition and heat treatment load, (2) the pallets and (3) the vacuum chambers

The sinter machine drive is located in the lifting station with the power of electric motor being transferred by the tooth segment of lifting sprockets to the pallet trust rollers. A torsion proof drum connects both lifting sprockets.

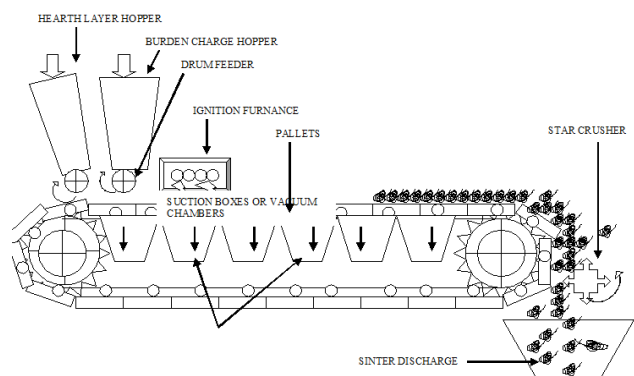

Figure 10. Travelling Grate Sinter Machine

The lifting and lowering sprocket shafts run in anti-friction bearings which are connected to a central lubrication system. Shaft mounted gearboxes are used for applying the starting torque. To be able to effect changes on the pallet travel speed, the drive side is equipped with a floating type bearing with adjustable equipment. Pallet travel speed can then be altered by varying the position of the lifting sprocket relative to the centre line of the sinter machine. A brief description of the major components mentioned above is attempted below:

- (1) Pallets: - A typical pallet consists of three main parts namely; the central frame, the sidewalls and the rollers. Depending on the design of the pallet may come as one piece or in three separate parts with the sidewalls and roller bearings attached to the central frames on site. The bottom of the pallets consists of fire grates which are replaceable. The materials for the pallet construction may be cast iron or cast steel.

(2) Vacuum Chamber: - Immediately below the sinter machine is the vacuum chamber inside which the rarefaction necessary to draw the process gas is created. To ensure efficient rarefaction, a tight seal must be achieved between movable pallets and stationary vacuum chambers in both longitudinal and traversal direction to the machine. For this purpose, sealing of strips is located on either of each pallet. Strings into the stationary vacuum chamber beams ensuring efficient sealing press the strips. Additionally, sealing plates are installed at the beginning and end of the suction area to effect the cross seal of the vacuum chambers.

(3) Sinter Machine Discharge End: - Sinter was discharged from the sinter machine through a crash deck to a single-roll tooth (star) crusher. Here the sinter was crushed to a maximum size of -250mm. An ideal sinter has the following features:

(a)The crush deck must be lined with special refractory bricks that will cool rapidly to ensure repairs around the roll crusher after only short stoppages.

(b)The parts must be quickly interchangeable to decrease short-down time.

(c)Wear-resistant material must be used in the crushing area.

(d)The geometry of the crushing system (point of impact, crushing angle, co-ordination of crushing facilities etc.) must be optimized.

8.2 Sinter Raw Material Stocking

All the raw materials delivered are crushed and ground to required particle sizes and are stocked in the appropriate stock bins (proportioning bins).

Table 7. Materials in Sinter Stock Bins

S/No.	Type Of Material	Delivery Capacity (t/hr)	Stock Period (hours)	No. of Bins.	Bins Capacity (tons)	No. Of Feeders
1.	Fe-materials	1,300	650	3	2,000	3
2.	Coke breeze	150	11	1	340	2
3.	Limestone/Dolomite	500	16	2	1,350	4
4.	Sinter returns	750	2.5	1	305	2

The operation of the feeders are;

(1) Fe-materials; 2 Feeders on, 1 stand-by.

(2) Limestone and Dolomite; 2 feeders on and 2 stand-by.

(3) Coke breeze; 1 feeder on and 1 standby.

(4) Sinter returns; 1 feeder on and 1 stand-by

The purpose of the stocking is to;

(1) Ensure the continuous flow of materials.

(2) To serve as a buffer in case of break down.

(3) To assist in changes in consumption pattern. Good stocking practice makes sure that bunkers and buffers are

run alternatively to eliminate caking or hanging of moist material in the bunkers due to long storage.

9. Proportioning Process at Materials Stock Bins

Proportioning means taking the exact amount of quantity of materials by weight required to make a given quantity of product. This proportioning was done at concentrate stockyard, sintering plant stock bins, sinter returns by calibration of feeders, and weigh scales to deliver the required quantity on tons per hour. The chemical analysis and stock level can change the consumption pattern or proportion to give the same quantity and quality of the product. To achieve this, charge calculation will predict the chemical analysis of sinter product. In addition, material balance will give the quantity expected. This calculation should be done as a priority before sampling. At ASCL, proportioning starts at Raw materials stockyard. At Raw materials handling, mill scales, BF Flue dust, manganese ore, sludge, lime dust, are added to the iron ore concentrate during delivery to the stock bins at sintering plant. Limestone and dolomite will be delivered in their consumption ratio to the hammer crushers. Charge calculation to predict the chemical analysis of the Fe-material is essential. This prediction and actual analysis are required for further charge calculation at the stock-bins-building to predict sinter analysis. At this stage, the proportioning processes should be well defined and predictions made. The formula for the supply of limestone and dolomite to the hammer crushers should be well defined as:

Annual consumption of limestone (L) = 300,000 tons

Annual consumption of Dolomite (D) = 240,000 tons

Therefore, consumption ratio = 3: 2.4 = 1: 0.8 = 5: 4

9.1 Primary & Secondary Mixing of Sinter Raw Mix (Pelletizing) Primary Mixing

The proportioned materials are mixed in a drum of dimension ϕ 4.2m x 12m slightly inclined at 2° 30' angle. The purpose is to homogenize the material such that each micro-volume of the sinter mix has an equal composition by weight of the materials proportioned.

The degree of homogeneity and the rate of discharge of materials depends on; (i)The speed of rotation of the mixing drum, (ii) Angle of inclination, (iii) Internal structures and (iv)Length of the drum.

The mixing drum has a variable speed control. On internal surfaces, ribs are welded to increase the resident time in the drum, thereby increasing the mixing efficiency. There is provision for water spraying in case of very dry material generating dust in the working area.

9.2 Secondary Mixing (Pelletizing)

The homogenized sinter mix is charged into another drum of dimension ϕ 4.2m x 24m long has provision for water spraying. The purpose of pelletizing is to increase the permeability of the sinter mix. The principle of pelletizing is based on the theory that small wet particles gently rolling over each other stick together with the aid of surface tension of water(liquid) in the presence of binding material (lime or bentonite) forming balls and segregating(Rolling) to the ends For pelletizing the following facts are related;

- (1) Speed of rotation of the drum, (2) Angle of rotation, (3) Moisture content (%), (4) Length of the drum.

The speed is inversely proportional to the pellet size. The higher the speed, the smaller the pellets. The higher the angle, the smaller the pellets. There is optimum moisture above or below which the pellet size becomes smaller.

9.3 Quality Control of Sinter

Despite the efforts made in proportioning and calibration there are still errors or malfunctions that are not easily determined until the result of the laboratory tests are obtained. The Detailed Project Report (DPR) specifies the sinter chemical analysis as follows:

- Ferrous total = 52%
- Manganese (Mn) = 1.06%
- Phosphorous (p) = 0.036%
- Sulphur (S) = 0.011%
- Ferrous Oxide = 13.55%
- Ferric Oxide = 60.29%
- Manganese Oxide = 1.33%
- Silica (SiO₂) = 9.43%
- Alumina (Al₂O₃) = 1.00%
- Calcium Oxide (CaO) = 12.09%
- Phosphorus Pentaoxide = 0.082%
- Sulphur Trioxide = 0.021%
- Others = 014%

9.4 Charge Calculation to Produce Sinter of Rated Basicity

Initial data for charge calculation are:

$$\text{Sinter Basicity} = \left(\frac{\text{CaO}}{\text{SiO}_2} \right) = 1.28$$

Table 8. Silica and Lime Content of Raw Materials at Stockyards

S/No	Materials From Stockyards	SiO ₂	CaO	L.O.I.
1.	Concentrate	9.3	0.66	1.5
2.	Dolomite	4.07	31.02	43.57
3.	Limestone	1.81	53.00	43.76
4.	Coke	7.0	1.00	85.00

Table 9. Material Consumption Rate

S/No.	Type Of Materials	Non-calcined (tons/hour)	Calcined (tons/hour)
1.	Concentrate	278.4	278.4x(100-LOI) = 278.4x0.985 = 294.22
2.	Dolomite	29.7	29.7x0.564 = 16.75
3.	Coke	30.3	30.3x0.15 = 4.54
TOTAL			295.61

Calculation of limestone requirement in tons:

1st calculate the amount of silica introduced into the burden charge through other raw materials i.e.

$$\begin{aligned} \text{Silica (SiO}_2\text{) in concentrate} &= 278.4 \times \% \text{ of SiO}_2 \text{ in Table 7} \\ &= 278.4 \times 0.093 = \frac{25.89t}{\text{Hour}} \\ &= 278.4 \times 0.093 = 25.89 \text{ t / hr.} \end{aligned}$$

$$\begin{aligned} \text{SiO}_2 \text{ in Dolomite} &= 29.7 \times \% \text{ of SiO}_2 \text{ in Table 7} \\ &= 29.7 \times 0.041 = 1.22 \text{ t/hr.} \end{aligned}$$

$$\begin{aligned} \text{SiO}_2 \text{ in Coke} &= 30.3 \times \% \text{ of SiO}_2 \text{ in Table 7} \\ &= 30.3 \times 0.07 = \frac{29.23t}{\text{Hour}} \end{aligned}$$

Total SiO₂ introduced through burden charge = 25.89 + 1.22 + 2.12

$$\frac{29.23t}{\text{Hour}}$$

= 29.23 t/hr.

The lime requirement to neutralize this silica and maintain the required basicity of 1.28 is given by;

$$\frac{\text{CaO}}{\text{SiO}_2} = 1.28$$

$$\frac{\text{CaO}}{29.23} = 1.28$$

$$\text{CaO} = \frac{29.23 \times 1.28 = 37.41 \text{ tonnes}}{\text{Hour}}$$

Now, to calculate the amount of CaO introduced into the burden charge through other raw materials as indicated in Table 7

CaO content in concentrate = 278.4 x % of CaO

$$= \frac{278.4 \times 0.0066}{\text{Hour}} = 1.84 \text{ tonnes}$$

CaO content in Dolomite = 29.7 x % of CaO

$$= \frac{29.7 \times 0.31}{\text{Hour}} = 9.20 \text{ tonnes}$$

CaO content in Coke 30.3 x % of CaO

$$= \frac{30.3 \times 0.01}{\text{Hour}} = 0.30 \text{ tonnes}$$

Total CaO introduced into the burden charge through other raw materials

$$= \frac{1.84 + 9.20 + 0.30}{\text{Hour}} = 11.34 \text{ tonnes}$$

The amount of CaO required to be introduced through the addition of Limestone

$$\frac{37.41 - 11.34}{\text{Hour}} = 26.07 \text{ tonnes}$$

Dry Limestone consumption is given by

$$= \frac{26.07}{(0.5 - \text{CaO required to neutralize SiO}_2 \text{ in the Limestone})}$$

$$= \frac{26.07}{[0.53 - (0.0181 \times 1.28)]}$$

$$= \frac{51.4 \text{ tonnes}}{\text{Hour}}$$

Limestone consumption at normal humidity of 2% is

$$\frac{51.4 \times 1.02}{\text{Hour}} = 52.43 \text{ tonnes}$$

To check for the basicity,

$$\text{Wt of calcined burden} = 295.61 + 52.43 \times 0.56$$

$$\text{Wt of calcined burden} = \frac{324.97 \text{ tonnes}}{\text{Hour}}$$

$$\text{Content of CaO in Sinter} = \frac{(29.23 \times \text{SiO}_2 \text{ in dry Limestone})}{324.97}$$

$$\text{Content of CaO in Sinter} = \frac{(29.23 \times 51.4 \times 0.0181)}{324.97} \times \frac{100\%}{1} = 9.28\%$$

$$\text{Content of CaO in Sinter} = \frac{11.34 \times 0.53 \times 51.4}{324.97} \times 100\% = 11.87\%$$

$$\text{Basicity of Sinter} = \frac{\text{CaO}}{\text{SiO}_2} = \frac{11.87}{9.2} = 1.28$$

Correction of the amount of Limestone with the charge of calcium oxide content e.g. CaO content decrease to 51%.

To produce Sinter with necessary basicity of 1.28,

it is necessary to increase the amount of Limestone by

$$= \frac{53 \text{ tonnes}}{51 \text{ tonnes}} = 1.039 \text{ times}$$

That is, the amount of Limestone after correction will be 51.4 x 1.039 = 53.4 tonnes

$$\text{For wet Limestone} = 53.4 \times 1.02 = \frac{54.46}{\text{tonnes}}$$

10. Pollution Control of Working Environment

On a general note, the receiving and stockpiling of various raw materials such as Iron ore concentrate and fluxes generate a substantial quantity of dust during handling through chutes and along with conveyor belts, especially in underground handling facilities. Dust pollution is hazardous to workers respiratory system; it causes chronic occupational diseases such as Silicosis, Pneumoconiosis, etc. For that reason, all the dust-generating points within the materials handling facilities of ASCL are connected with a network of dust extraction pipes by means of induced draught Fans using either Electrostatic precipitator, Venturi scrubber or Fibre bag filter as the case may be, recovered dust is recycled back into the system. This singular advantage of cleaning the working environment and recycling the scarce and expensive raw materials back into the process line that could have been lost to the atmosphere justify the huge capital investment in their installation. The technical and process description of the three types of aspiration plants used will be briefly discussed below.

11. Electrostatic Precipitator Technical Description

Electrostatic precipitator consists of the following:

(1) A rectangular sections of the diffuser (for gas inlet) and confuser (for gas outlet) adjoined to section's faces; (2) Hoppers at the lower part of the housing to collect and remove the recovered dust; (3) Housing is covered by glass fiber in some units as a heat insulator to prevent cooling of process gases, which could lead to moisture condensation of noxious gases (SO₂ and H₂O) because of temperature drop; (4) Collecting electrodes, discharge electrodes, jolting mechanisms of the electrode, insulator units and gas-distributing grids are

assembled inside the housing; (5) Discharge electrodes are connected at the top to a high-voltage feed source of rectified current 50-60 KV; (6) Collecting electrodes are earthed through the body of the housing; (7) Side-walls of housing are solidly made from 6mm thick steel plates with horizontal ribs to provide structural stability; (8) Housing roof has an aperture used for assembly of equipment and installation of insulators; (9) Gas distributing grids were installed at diffuser (gas inlet) side to distribute gas evenly along all sections of the electric filter; (10) Collecting electrode of frameless construction is arranged in the vertical position in the same plane and all cells must be parallel to each other. Each cell is 640mm wide and hung to suspension beams by brackets; (11) Jolting beam consists of two strips 10 x 80mm connected between them by anvil from the impact end, and from the opposite by insert; (12) Discharge electrodes are flat bar frames with taut tape-needle members, turn of needles are directed parallel to gas flow; (13) All electrodes are installed on suspension frames by means of brackets. Suspension frames support top brackets freely; threaded joints of lower brackets are tightened and welded round; (14) Suspension frames of discharge electrodes together with the discharge electrodes form a common system, which was hung on suspension pipes, china base through high tensile strength insulators, and it is adjustable; (15) Jolting mechanism of discharge electrode has a reciprocating motion with provision for adjustments. Maximum the angle of lift of hammer is 60° and height of lift is 100 mm; (16) Jolting mechanism of collecting electrodes was assembled by blocks. Each block consist of a shaft with hammers, couplings and bearings mounted on the frame. The shaft of blocks are connected together by couplings, and frames are fixed to the housing; (17) Jolting mechanism of both electrodes is driven by means of gear motors mounted on speed reducers with maximum. The output torque of 150kgm and 0.2rpm; (18) A combined units of disc gate and sluice feeders are installed bellow the hoppers for continuous discharge of collected dust to scrapper conveyor for recycling and (19) Hatches and doors are provided for accessibility into the ESP during inspection and repairs.

12. Process Description

Electrostatic precipitator operates based on the principle that; When two electrodes are connected to a high rectified voltage of 50-80KV, a coronary discharge of electrons from highly insulated negative (discharge) electrode to earthed positive (collecting) electrode occur.

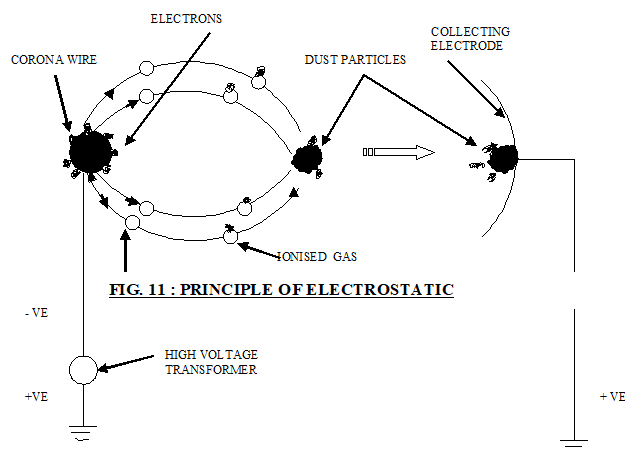

Figure 11. Principle of Electrostatic Precipitator

The corona discharge from highly insulated negative (discharge) electrode ionizes the gases and the ions become attached to the dust particles, then rapidly across to the earthed collecting electrode from which they are removed at regular intervals by means of jolting mechanism and the dust particles are collected at the bottom hopper. The transit time through the cells must be sufficient to allow each particle to travel across the width of the cells (electrodes) under electrostatic forces that is applied to it. The high-voltage rectified current is led to electrodes of ESP along high voltage cable. At the rectifier, positive terminals are earthed while negative terminals are properly insulated and connected to discharge electrode through high voltage cable. High-voltage, low current is supplied to discharge electrode, the electric field is generated in the ESP between discharge and collecting electrodes. Voltage quantity of the field is increased automatically by a thyristor-controlled circuit until the maximum voltage of 80 kV is reached. As the voltage increase approaches maximum, corona discharge arises in the space between the two electrodes. Induced Draught (ID) Fan suck process gases containing dust particles through the ESP, weighted particles contained in gases are admitted into ESP through the diffuser and gas-distributing grids for uniform gas distribution throughout the ESP chamber. They are ionized and carried by the moving ions. Ionized particles under the influence of electric field move to collect electrodes and settle them temporarily, cleaned gases continue to move through the electric field until it reaches confuter at the end of ESP and flows through the gas duct to ID Fan and stack. The temperature must be maintained above due points of both Sulphur dioxide and steam because of their deleterious effect of corroding the structural members and ID fan impeller blades. Once the maximum voltage is reached, the thyristor cut-off the voltage to zero and the

jolting mechanism rap and shake the collecting electrodes thereby dropping the collected dust particles inside the hopper below. The circle is repeated throughout the operating time, collecting dust in the hopper is periodically and incessantly removed by means of sluice feeder and scrapper conveyors back to the process line.

12.1 Technical Description of the Venturi Scrubber

Venturi scrubber consists of the following: (1) The venturi scrubber of model KMP-8 consists of a venturi tube (tube-coagulator) with a hydraulic seal which creates a water curtain at the bottom discharge end; (2) The venturi tube consists of a casing, 30mm jet nozzle and water chamber for water film spraying along the inner surface of the venturi tube expander with a combined flow rate of 31.5m³/hr.; (3) The venturi tube was of welded design and consists of an air inlet pipe from the top, which admits air at the rate of 105,000m³ /hour, a throat and expander. Main water supply was provided through the 30mm jet installed at the central axis of venturi throat, the jet nozzles are easily detachable; (4) Additional water supply for the chamber flowing down in the shape of a uniform film along the entire inner surface of the venturi tube was also provided; (5) When filling the chamber with water, a hydraulic seal preventing air in-leakage from the environment is created; (6) When filling the chamber with water, a hydraulic seal preventing air in-leakage from the environment is created, Water was supplied to the chamber through the semi-circular 25mm pipe and two numbers. 25mm gate valves connected to the chamber's outer periphery The chamber was covered with Iron sheets at the top; (7) Openings for removal of sludge during repairs and cleaning are provided at the bottom discharge outlet; (8) The spray tower of type ЗИЛ-900 (drop catcher) consists of a casing and a branch pipe in the lower part meant for air supply from venturi (coagulator) and a scroll used for removal of cleaned air at the top of the spray tower. Cleaning efficiency that can be achieved is up to 97.5% and dust particles in the emissions not to exceed 1.43mg/m³; (9) Sludge formed as a result of gas cleaning is removed from spray tower through the hydraulic seal in the lower the casing. For periodic flushing, the part of hydraulic compartment was supplied with water through 25mm gate valve; (10) For flushing of internal walls of spray tower, periodic spraying of the walls by means of nozzles installed at the upper part of the casing was done. Water is supplied to the nozzles through a circular pipe around the circumference of the spray tower; (11) For observation and visual inspection of the inner wall of the spray tower, an inspection man-hole is provided, 2 Nos. Instrumenta-

tion cabinets are provided at the ground floor with gauges for measuring suction pressure from 0-63kgf/m² and water flow rate from 0-50m³/hour, a switch knob for starting and stopping the system was also provided by the side of the instrumentation cabinet; (12) Suction of dust-laden gas through the venturi scrubber is achieved by an exhauster fan of type D18X2T with a capacity of 180,000m³/hour, it was driven by a high tension electric motor with a power rating of 320KW and 6.6KV supply; (13) The exhauster motor was interlocked with maximum sludge level sensor in the spray tower and main water supply motorized gate valve.

12.2 Process Description

Venturi technically means narrows to a throat and then gradually increase to the original diameter, it was used in fluid mechanics to generate turbulence flow in fluids.

The basic principle of the venturi scrubber (wet coagulation dust catcher) is to provide intimate contact between the collecting fluid and the contaminant in the air to be cleaned. When the contaminant is particulate, the wetting of the particle increases its mass and it becomes relatively easy to remove from the air stream. The intimate mixture of air and liquid provides a large interface area between the two media so that solution or reaction of the contaminant was enhanced; the efficiency increases with pressure drops. In venturi scrubber type KMP-8, the contaminant air is passed through a venturi throat at a very high velocity of about 100m/sec and flow rate of 105,000m³/hr. Water, which is simultaneously fed in at a rate of 31.5m³/hour into the throat was atomized by the turbulent air into a fine fog. The intimate mixing of the contaminant and water in the turbulence created by the venturi results in rapid wetting and collection, pressure losses is as high as 330mm (13.2 inches) and the efficiency of separation is estimated at 97.5% in the sub-micron particle size range.

13. Fibre Cloth Bag Filter: Technical Description

Fibre cloth bag filter (Bag filter) consists of the following: (1) Each unit is made up of rectangular box measuring 6000mm x 2000mm x 2200mm divided into eight compartments each measuring 1500mm x 100mm x 2200mm; (2) Each compartment contain 24 Numbers of bag filters, a total of 96Nos. for each unit of eight compartments; (3) Dimension of each bag was □200mm x 2200mm height; (4) Each bag is hooked with a spring from the top end in addition to bag clamp to prevent the downward collapse of the bag in the event of upper clamp failure to grip; (5) Each compartment is provided with a baffle at the bottom

end entrance into bags compartment for controlling alternate exhaustor suction and counter flow of compressed air supplied by solenoid valves; (6) Each compartment is provided with an electrically activated programmed solenoid valve for controlling compressed air supply for the purpose of cleaning filter bags; (7) Bottom hoppers of all the eight compartments are connected with a common pipe for discharging the collected dust back to process line; (8) The exhaustor fan model цм6-45N8 has a capacity of 15,500m³/hour with 37KW electric motor or model цм6-45N8 which has a capacity of 8,100m³/hour with 22KW motor depending on specific design requirement, the type installed in each unit depends on the dust emission rate in the unit. There are a total of 24 units in the whole section under study; (9) A start and stop push button switch is provided near each exhaustor fan motor and (10) Electro-pneumatic programmed box is mounted on each control panel board (CPB) controlling each exhaustor fan motor.

Process Description

By sucking action of exhaustor fan through suction hoods, dust-laden air enters one section of the fabric and emerges through the other side as cleaned air and discharge to the atmosphere through the chimney. The cleaning process is not simple filtration since the pores of the medium are usually much larger than the particles to be collected. When the cloth bag filter is new, much dust will pass through the filter until a bed of deposited dust was built upon the fabric. The process was complicated, it involves impingement of the particles on the fibres, as well as deposition of the particles under the influence of settling, Brownian motion and static electricity created by flowing air. The dust mat will rapidly build upon the medium, and it was this mat, rather than the fabric, which acts as the filtering agent.

A permanent dust base will be created within the pores, which will not be dislodged by shaking so that cleaning efficiency remains high. The most commonly used fabric medium for normal application such as cleaning of concentrate, fluxes and coke dust is cotton or wool sateen/felt. The size of the filter, i.e. the area of filter medium through which a given stream of air passes, will affect the resistance to airflow and therefore the required exhaustor fan motor with a power rating of 37KW and 22KW was installed at different units depending on projected (anticipated) dust emission. Normal resistance (i.e. pressure drops) of the filter to flow of air with a ratio of 3 to 1 used was 75mm of water.

An important feature of the design of bag filters is the inflation of the bags during suction and their sudden

collapse during counter-current flow of compressed air, which serves as a shaking mechanism during a circle of bag cleansing. When the solenoid valve is activated, it releases a pressurized compressed air which was deflected upward into bags compartment by a baffle at the same time blocking suction from exhaustor fan from below. Compressed air was blown through the fabric in a counter-current to the flow of clean air, which equally serves as a shaking mechanism to the bags. The shaking mechanism must vigorously rap, shake and flex the fabric to discharge the dust, which may adhere very firmly.

The shaking circle must as indicated be frequent enough to ensure continuous maintenance of the designed filtration rate, an automatic interlock between exhaustor fan motor solenoid valves is provided such that the solenoid programmer was only activated when the exhaustor fan motor is switched on. The material caked on the cloth was continuously dislodged from the surface and since it is agglomerated, is not restrained in the airstream but fall to the collecting hopper. The resistance after the initial build-up is essentially constant at the suction hoods, branch pipe velocity of 1,350-1,670 meters per minute for concentrate, fluxes and coke specks of dust were adopted.

14. Conclusion and Recommendation

There is no gainsaying the fact that an integrated steel plant like Ajaokuta Steel Company Limited can only be successfully operated with a sure guarantee of regular and timely supplies of bulk raw materials input. The bulk raw materials requirements like Iron ore concentrate, limestone, dolomite and coking coal are locally sourced and are available in the country except for coking coals which require high-grade foreign coals to be blended with low-grade local coal.

Therefore, adequate planning and logistics for their exploitation and transportation to site via road and railway systems, storage and handling will ensure not only the smooth operations but also the economic promotions for various operations of an integrated Iron and Steel Plants.

The various types of machinery and facilities made available on site for the bulk materials handling are so designed to ensure smooth expansions from the initial 3 million tonnes, to 2.6 million tonnes and 5.6million tonnes signifying the first, second and third phases of liquid steel production per annum at ASCL.

The provision of highly rated and tested tipping, off-loading and stocking facilities at various stockyards was a significant assurance of uninterrupted operations. The advantages of the suggested techniques of stocking and blending are:

- (1) Reduction of the overall price of raw material uti-

lized, by carefully balancing the rich and poor materials to obtain the desired overall requirement in a burden; (2) During shortage conditions of the grade of material normally utilized, a blending system is sufficiently flexible to make possible the use of lower or higher grade of materials, which are readily available; (3) Almost invariably, variations of physical and chemical characteristics occur within different sections of a mine, and if a blending operation was incorporated, the extra expense of selective mining in order to obtain a measure of uniformity within the burden can be reduced; (4) The use of blended ores in the blast furnace prevents the local agglomeration of fine ores which fills the natural voids and obstruct the free flow of gas through the stack; excessive voids created by lump concentration causing hot spots are also eliminated; (5) Demurrage charge on railway wagons can be greatly reduced if carefully planned blending facilitates quick turn round; (6) Material bedded out before reclaiming provide buffering for breakdown emergencies of incoming materials; (7) The extension of raw material reserves is possible by making use of lower grade materials readily acceptable with blending and bedding; (8) Some of the coals used for coking ovens are prone to spontaneous combustion and cannot be safely stored for more than three weeks. When these are blended with coals of differing characteristics, the possibility of spontaneous combustion was reduced to a minimum; (9) There is an increase in the coke oven linings due to the charge being consistency at all times and (10) Due to the evening out of the chemical characteristics of ore fines for sintering, the consumption of coke (coke rate) during the process can be reduced, depending on the lime/silica ratio. This is obviously more economical. However, it must be pointed out here that a careful balance must be maintained between lime at the sinter plant and limestone at the Blast furnace.

Conflict of Interests

The authors declare that there is no conflict of interests regarding the publication of this paper.

References

- [1] Detailed Project Report (DPR) of Ajaokuta Steel Company Ltd; By TiajPromeExport (TPE) of Russia 1980c
- [2] Caen-Vachette, M., Umeji, A. C. Geology and Geochronology of the Mfamosing area. Evidence of crystalline Limestone formation in economic quantity. *J. Afr. Earth Sci.*, 1987, 7: 121-126.
- [3] Mogbo, O., Okoro, A.U., Oluyede, P. O., Muotoh, E. O. G. The Itakpe Hills Iron Ore formations. First Symposium on the Precambrian Geology of Nigeria, Kaduna, 1981
- [4] Kennedy, W. Q. Analysis of Bulk Materials Blending Techniques and Related Equipment. 8th Annual Report American Institute of Metallurgy, 1984, 61: 243-250.
- [5] PACS-MECON (India). Annual Report on Ajaokuta Steel Company. 1986: 156-167.
- [6] Linchersky, B. Iron and Steel making. 4th edition, 1990
- [7] U.S.Steel Publication: The Making, Shaping and Treating of Steel, 19th Edition, 1975.
- [8] Basic Oxygen Furnace Steelmaking: <https://www.steel-technology.com/articles/oxygen-furnace>
- [9] E.T. Turkdogan "Fundamental of Steel Making" The Institute of Materials Book 656, First Published by the Institute of Materials 1 Carlton House Terrace London SW1Y 5DB, 1996.
- [10] Carl-Erik Grip, Johan Isaksson, Simon Harvey, Leif Nilsson. Application of Pinch Analysis in an Integrated Steel Plant in Northern Sweden. *ISIJ International*, 2013, 53(7): 1202-1210.
- [11] C. Mapelli and S. Baragiola: Ironmaking Steelmaking, 200633: 379.
- [12] C. Ryman: *Iron Steel Technol.*, 2011, 8: 61.
- [13] C. E. Grip, M. Larsson and J. Dahl: Proc. 84th Steelmaking Conf., ISS, Warrendale, PA, 2001: 543.
- [14] Dawson, P. R., *Ironmaking Steelmaking*, 1993, 20: 137-143.
- [15] Hsieh, L. H., Proc. On Iron and Steel Tech. Conf. Indianapolis, IN, USA. Association for Iron and Steel Tech., Warrendale, PA, USA. 2007, 1: 207-214.
- [16] Cumming, M. A. and Thurlby, J. A., *Ironmaking Steelmaking*, 1990, 17: 245-254.
- [17] Cappel, F., ISS Ironmaking Conf. Proc., 1991, 50: 200.
- [18] Yamaoka, Y., Nagaoka, S., Yamada, Y., Ando, R., *Trans. Iron Steel Inst. Jpn.*, 1974, 14: 185-194.
- [19] D. Fernández-González, I. Ruiz-Bustinzab, J. Mochónb, C. González-Gascac, L. F. Verdeja. Iron Ore Sintering: Process" *Mineral Processing And Extractive Metallurgy Review* 2017, 38(4): 215-227. <http://DX.DOI.Org/10.1080/08827508.2017.1288115>
- [20] Fernández-González, D., Martín-Duarte, R., Ruiz-Bustinzab, I., Mochón, J., González-Gasca, C., Verdeja, L. F. Optimization of sinter plant operating conditions using advanced multivariate statistics: Intelligent data processing. *JOM*, 2016, 68: 2089-2095.
- [21] Fernández- González, D., R., Ruiz-Bustinzab, I., Mochón, J., González-Gasca, C., Verdeja, L. F. Iron ore sintering: Raw materials and granulation. *Mineral*

- Processing and Extractive Metallurgy Review, 2017, 38: 36-46.
- [22] Ishikawa, Y., Kase, M., Sasaki, M., Satoh, K., Sasaki, S. Recent progress in the sintering technology- High reducibility and improvement of fuel consumption. Ironmaking Conference Proceedings, 1982, 41: 80-89.
- [23] Ishikawa, Y., Shimomura, Y., Sasaki, M., Hida, Y., Toda, H. Improvement of sinter quality based on the mineralogical properties of ores. Proceedings of the 42th Ironmaking Conference, AIME, Atlanta, 1983: 17-29.
- [24] Yang, W., Choi, S., Choi, E. S., Ri, D. W., Sungman, K. Combustion characteristics in an iron ore sintering bed: evaluation of fuel substitution. Combustion and Flame, 2006, 145: 447-463.
- [25] Yasumoto, S., Tanaka, S. Continuous measuring of heat pattern in sintering bed and its application to sintering operation. Kawasaki Steel Technical Report, 1982, 5: 1-8.
- [26] Otomo, T., Taguchi, N., Kasai, E. Suppression of the formation of large pores in the assimilated parts of sinter produced using pisolitic ores. ISIJ International, 1996, 36: 1338-1343.
- [27] Dawson, P. Determination of the high temperature properties of blast furnace burden materials. SEASIS (South East Asia Iron and Steel Institute) Quarterly Journal, 1987, 16: 23-42.
- [28] Loo, C. E., Matthews, L. T., O'Dea, D. P. Lump ore and sinter behavior during softening and melting. ISIJ International, 2011, 51: 930-938.
- [29] Eisele, T. C., Kawatra, S. K. A review of binders in iron ore pelletization. Mineral Processing and Extractive Metallurgy Review, 2003, 24: 1-90.
- [30] Patisson, F., Bellot, J. P., Ablitzer, D., Marlière, E., Dulcy, C., Steiler, J. M. Mathematical-modeling of iron-ore sintering process. Ironmaking and Steelmaking, 1991, 18: 89-95.
- [31] Dawson, P. R., Ostwald, J., Hayes, K. M. The influence of sintering temperature profile on the mineralogy and properties of iron ore sinters. Proceedings of the Australian Institute of Mining and Metallurgy, 1984, 829: 163-169.
- [32] Usamentiaga, R., Molleda, J., García, D. F., Bulnes, F. G. Monitoring sintering burn-through point using infrared thermography. Sensors, 2013, 13: 10287-10305.
- [33] Toda, H., Senzaki, T., Isozaki, S., Kato, K. Relationship between heat pattern in sintering bed and sinter properties. Transactions of the Iron and Steel Institute of Japan, 1984, 24: 187-196.
- [34] Hsieh, L., Liu, K. Influence of material composition on the softening and melting properties of blast furnace burden materials. Ironmaking Conference Proceedings, 1988, 57: 1623-1632.