

ARTICLE

Inventory Management and Demand Forecasting Improvement of a Forecasting Model Based on Artificial Neural Networks

Cisse Sory Ibrahima^{1*} Jianwu Xue¹ Thierno Gueye²

1. School of Management, Northwestern Polytechnical University, Xi'an, 710072, China

2. School of Mechanical engineering, Northwestern Polytechnical University, Xi'an, 710072, China

ARTICLE INFO

Article history

Received: 16 May 2021

Accepted: 28 May 2021

Published Online: 24 August 2021

Keywords:

Inventory management

Demand forecasting

Seasonal time series

Artificial neural networks

Transfer function

ABSTRACT

Forecasting is predicting or estimating a future event or trend. Supply chains have been constantly growing in most countries ever since the industrial revolution of the 18th century. As the competitiveness between supply chains intensifies day by day, companies are shifting their focus to predictive analytics techniques to minimize costs and boost productivity and profits. Excessive inventory (overstock) and stock outs are very significant issues for suppliers. Excessive inventory levels can lead to loss of revenue because the company's capital is tied up in excess inventory. Excess inventory can also lead to increased storage, insurance costs and labor as well as lower and degraded quality based on the nature of the product. Shortages or out of stock can lead to lost sales and a decline in customer contentment and loyalty to the store. If clients are unable to find the right products on the shelves, they may switch to another vendor or purchase alternative items. Demand forecasting is valuable for planning, scheduling and improving the coordination of all supply chain activities. This paper discusses the use of neural networks for seasonal time series forecasting. Our objective is to evaluate the contribution of the correct choice of the transfer function by proposing a new form of the transfer function to improve the quality of the forecast.

1. Introduction

To face a competitive and uncertain economic context, as the one in which companies find themselves today, reactivity is no longer enough. Beyond agility and industrial flexibility, companies must be able to anticipate. Without the effort of anticipation, it will be difficult for companies to meet the increasingly personalized and diversified expectations of their customers. This inability of the company will give an advantage to competitors, because dissatisfied

customers will turn to similar products to fulfill their expectations. A lack of coherence between the demand and the means implemented to satisfy it can lead to important stocks, or sales losses due to stock shortage, which, beyond the notion of costs inherent to the logistic means, represents a deterioration of the company's image and a damaging loss of its turnover.

The goal of companies is to be able to satisfy an increasingly diversified demand, in a short period of time and with minimum stocks. To achieve this, they must have

*Corresponding Author:

Cisse Sory Ibrahima,

School of Management, Northwestern Polytechnical University, Xi'an, 710072, China;

Email: sorycisse771@gmail.com

a global vision of the chain that allows them to reach an optimization as a whole.

Demand forecasting is a key tool by which the company can face the uncertainties related to the future.

When demand is seasonal, the production capacity is not sufficient to absorb the peak demand. It is therefore necessary to launch production in advance based on sales forecasts.

Production that is lower than demand leads to a loss of margin (direct cost of stock shortage) to which is added the indirect cost of shortage (customer dissatisfaction). In the opposite direction, excess production compared to sales results in overstocking. It is therefore not possible to plan or set objectives without first making a forecast. There must be a strong connection between the business plan and the sales forecast.

There are several qualitative and quantitative techniques for forecasting demand. This paper deals with the use of neural networks for seasonal time series forecasting. In our model the time series is used without prior decomposition. This is justified by the ability of neural networks to implicitly take into account the trend and seasonality as well as the irregularity of demand based only on the historical data of the variable to be forecasted^[1].

Several neural network architectures have been evaluated for forecasting time series, and the present work focuses on the contribution of the right choice of the transfer function to improve the quality of the forecasts. After evaluating several standard functions, a new form of transfer function is proposed. The computed forecasts have been compared and conclusions are drawn about the choice of the transfer function and the contribution of this new form for the case of seasonal time series forecasting.

The rest of the paper is organized as follows: section 2 presents a review of the literature concerning demand forecasting and the use of neural networks in this domain. In section 3 the developed neural model is presented focusing on the effect of the "transfer function" parameter on the quality of the forecast. Section 4 is reserved for the discussion of the results. At the end section 5 gives a conclusion.

2. Literature Review

Qualitative forecasting techniques can be grouped into two categories: time series and causal methods. The purpose of time series analysis is to determine a model that explains the history of changes and extrapolates the time series into the future prediction horizon. This is done in the belief that the demand data represents an experiment that repeats itself over time^[2].

This category includes the naive method, the moving

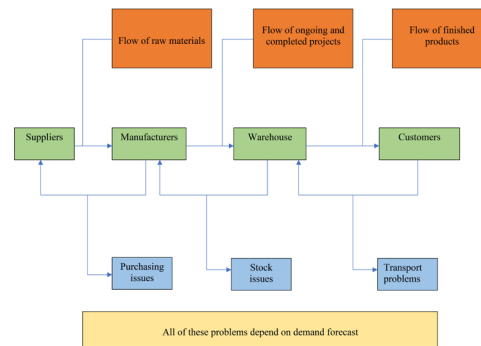

Figure 1. Demand Forecasts and their roles in supply chain

average, exponential smoothing and ARIMA (Autoregressive Integrated Moving Averages) models. These techniques consider that the data are only a function of time. Their use is desired when looking for the general trend of changes without considering the factors that influence demand^[3].

One of the factors of popularity of these time series analysis models is their ease of use and implementation. However, these techniques are unable to model the data nonlinearity present in seasonal time series. Artificial neural network modeling is a promising alternative to overcome this limitation^[4]. Mitrea, C.^[5] compared different forecasting methods such as the moving average and the ARIMA model with neural network models. Neural network resources go as far back as the 1940s when the first mathematical pattern of a biological neuron was published by McCulloch and Pitts (Picton, 2000). In 1949, Donald O. Hebb demonstrated the structure of neural networks' learning process. It was during the 1950-60s that scientists were able to develop the first artificial neural network with the ability to learn based on Hebb's rule. Research papers on neural networks during the 1970s were primarily concerned with associative memory and neurophysiological models (Nauck et al., 1997).

Nowadays, researchers need to become familiar with a wider assortment of networks, all differing in network architecture, learning strategies and, weighting methods (Picton, 2000). Modern research in the field of neural networks, also referred to as connectionism, including the development of new network architectures and learning algorithms.

The research also tests the applicability of these newer models to information processing tasks (Nauck et al., 1997).

Artificial neural networks have been utilized in a vast range of applications such as pattern classification,

identification, optimization, prediction and automatic control. Despite different structures and training paradigms, all neural network applications are special cases of vector mapping (Tarafdar and Kashtiban, 2005). They have also been widely touted as solving many forecasting problems (Marque et al., 1992). The well-known task approximator in predicting and system modeling has lately shown great applicability in time series analysis and forecasting (Kamruzzaman & Saker, 2003).

The results show that the use of neural networks for time series forecasting gives better performance than traditional methods. After being properly configured with historical data, artificial neural networks (ANNs) can be used to accurately approximate any measurable function. Because they are fast and accurate, many researchers use ANNs to solve demand forecasting problems. ANNs provide outstanding results even in the presence of noise or missing information [6].

3. Methodology

3.1 Decomposition of a Seasonal Time Series

Most time series are made up of a combination of three elements: trend-cycle behavior (TS), seasonal effects (S) and irregular fluctuations (IR).

Trend-cycle (TS), seasonal effects (S) and irregular fluctuations (IR). Usually, we choose one of the following two models to describe how these components might fit together in a time series:

Additive model: $Y=TC+S+IR$

Multiplicative model: $Y=TC \times S \times IR$

Where Y is the original series, TC is the trend-cycle, S is the seasonal component, and IR is the irregular component.

Seasonal decomposition is a process of estimating the seasonal component called seasonal factors using a sequence of moving averages and smoothing to decompose the original series into trend, seasonal component, and irregular components [7].

Once the seasonal factors are defined, the original series is divided (for multiplicative models) or subtracted (for additive models) by seasonal factors to find the seasonally adjusted series that can be extrapolated into the future.

3.2 Multi-layer Perceptron

By analogy to biological neurons, an artificial neural network must be able to learn and reproduce "intelligent" reasoning in an artificial way (each inter-neuronal connection of the network will be able to adapt and evolve

as it learns).

Multilayer perceptron's (MLP) is the type of neural network most commonly used in approximation and optimization problems. Organized in layers, an MLP allows an one-way flow of data from the inputs to the outputs of the network [8]. An example of a multilayer perceptron is shown in Figure 1, which consists of an input layer, two hidden layers and an output layer.

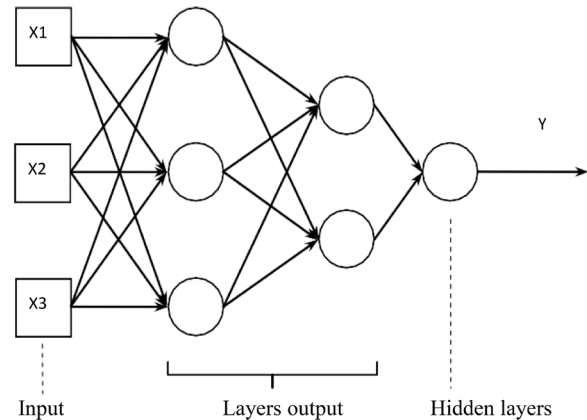

Figure 2. Multi-layer perceptron

A neuron with multiple inputs and a single output is shown in Figure 2. Two functions determine how the signals are processed by this neuron. The activation function determines the total signal that the neuron receives. It is given by the dot product of the inputs with the weight vector:

$$I_i(x) = \sum w_{ij} x_j$$

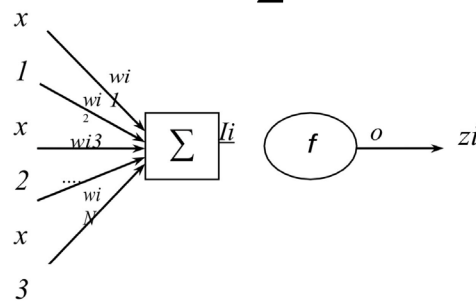

Figure 3. Representation of a neural network

The second function is the output function $f(I)$. The combination of the two functions constitutes the transfer function which allows to compute the output of the neuron from the input data. For neuron i connected to neurons j ($j=1, \dots, N$), the output signal o_i is given by :

$$O_i = f(I_{i(x)}) = f(\sum w_{ij} x_j)$$

The choice of transfer functions at the hidden and output neurons has an important impact on the performance of the model. For a nonlinear forecasting problem, sigmoid

functions are usually used at the hidden layer, and linear functions are used at the output layer.

Depending on the problem studied and the neural network architecture adopted, several activation functions can be used. Here are some examples:

Table 1. Transfer functions

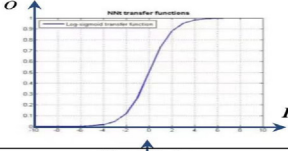
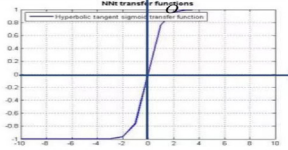
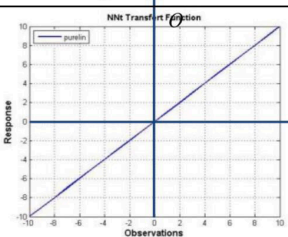
Model	Representation
Sigmoide Logistics $O=f(I) = \frac{1}{1 + \exp(-I)}$	
Hyperbolic Tangent $O=f(I) = \frac{2}{1 + \exp(-2*I)} - 1$	
Model	Representation
Linear function $O=f(I) = I$	

In addition to these three transfer functions, we have proceeded to the design of a new form of transfer function. As shown in Figure 4, this function is constructed by combining a logistic sigmoid with a hyperbolic tangent. This function named in the figure by HTLog-Sigmoid takes the minimum value of the two above mentioned functions.

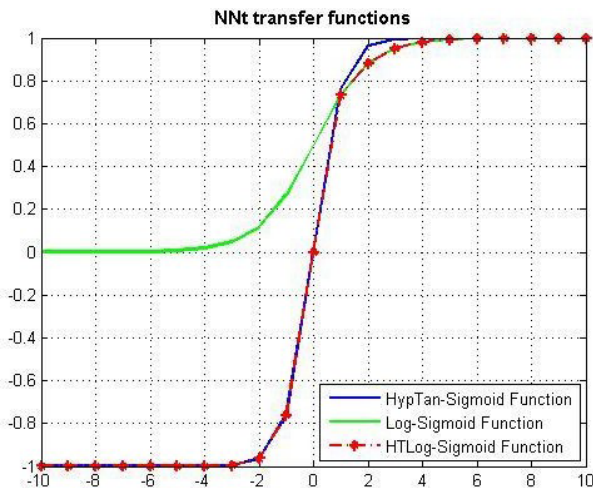

Figure 4. New tra nsfer function: HTLog-Sigmoid

3.3 Forecasting the Time Series by the Multi-Layer Perceptron

To estimate the demand of the next month knowing the sales realized in the last five months for example, we design a MLP with five inputs corresponding to the past sales, an output layer with a single neuron corresponding to the sales expected next month.

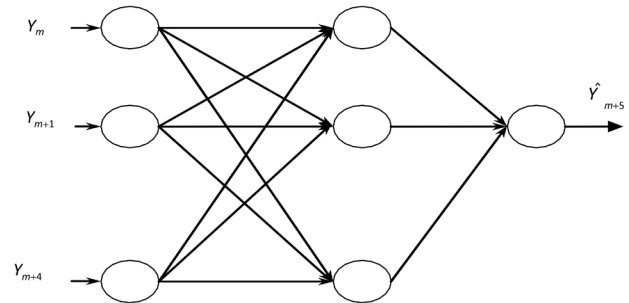

Figure 5. MLP for time series

In a general way, the prediction model of a time series by a multilayer perceptron is given by:

Where:

$$\hat{y}_t = f(y_{t-1}, y_{t-2}, \dots, y_{t-n})$$

- \hat{y}_t is the next demand estimated by the MLP,
- $(y_{t-1}, y_{t-2}, \dots, y_{t-n})$ are the input data corresponding to an observation window of width 'n' on the time series.

There is no objective formula to choose the parameter n and the number of neurons in the hidden layer. It is by the principle of trial and error that their values are evaluated to give the right result on the predictions [9].

4. Results and Discussions

4.1 Generation of Demand Data

The generation of data is done by simulation by adding three components related to the cycle trend TS the seasonal component S and the irregularity IR: $Y = TC + S + IR$

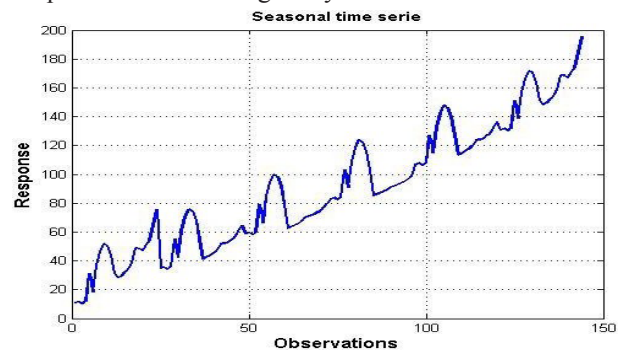

Figure 6. Time series generated by simulation

4.2 Choice of Parameters

The choice of the MLP architecture also consists in setting, referring to the test results, the best parameters of the neural network are the following:

- Number of neurons in the input layer: 08
- Number of neurons in the hidden layer: 04
- Learning algorithm: Levenberg-Marquardt backpropagation algorithm.

4.3 Comparison of the Transfer Functions

To evaluate the impact of the choice of the transfer function on the quality of the predictions using neural networks, we will compare the results obtained by employing the two standard transfer functions widely used for the prediction problem, as well as the newly designed function.

1) Simulation with a hyperbolic tangent:

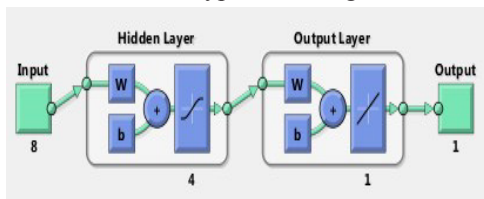

Figure 7. Structure of the ANN with a hyperbolic tangent

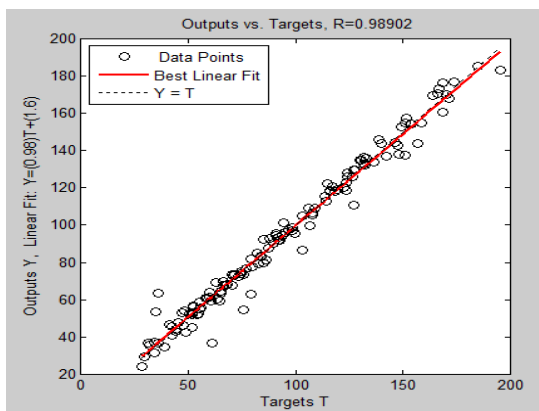

Figure 8. Regression coefficient obtained using the symmetric sigmoid: Hyperbolic Tangent

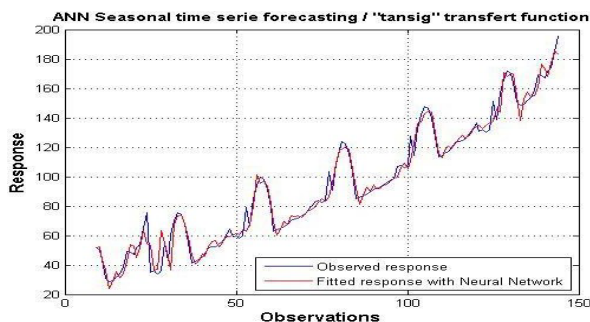

Figure 9. Response obtained with a symmetrical sigmoid (hyperbolic Tangent).

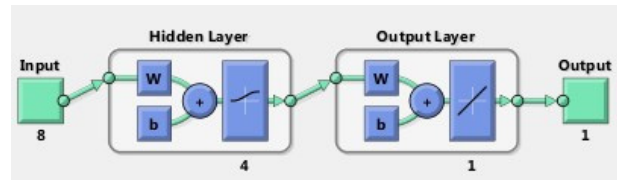

Figure 10. structure of ANN with a logistic sigmoid

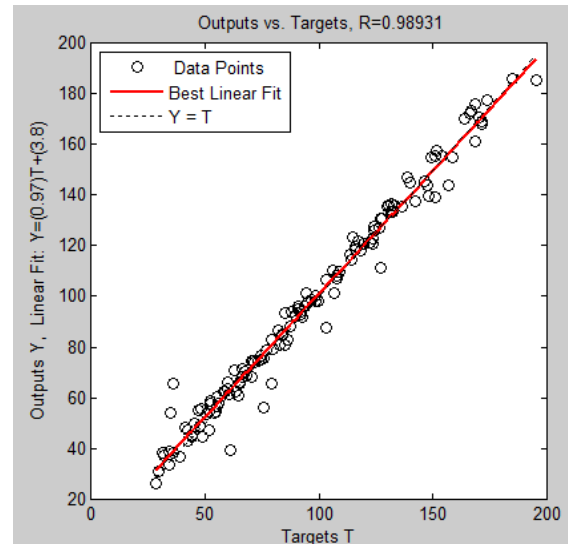

Figure 11. Regression coefficient obtained using a logistic sigmoid

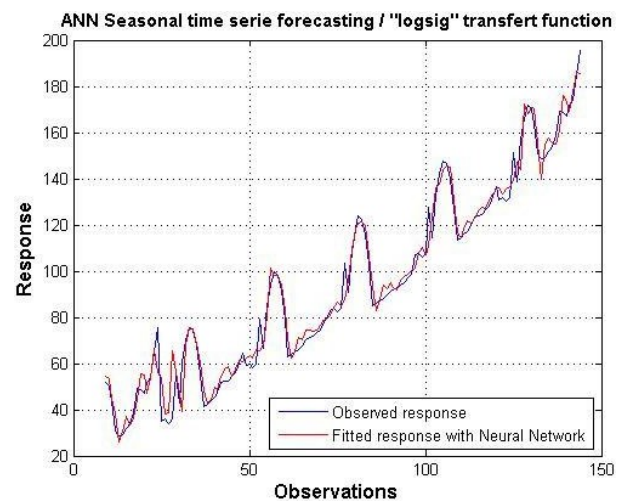

Figure 12. The response obtained with a logistic function

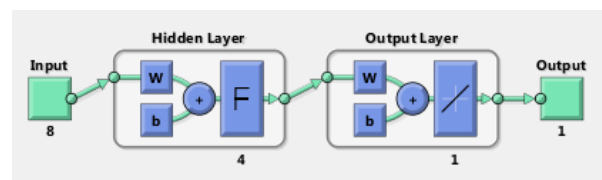

Figure 13. Structure of the ANN with a Function HTLog-sigmoid

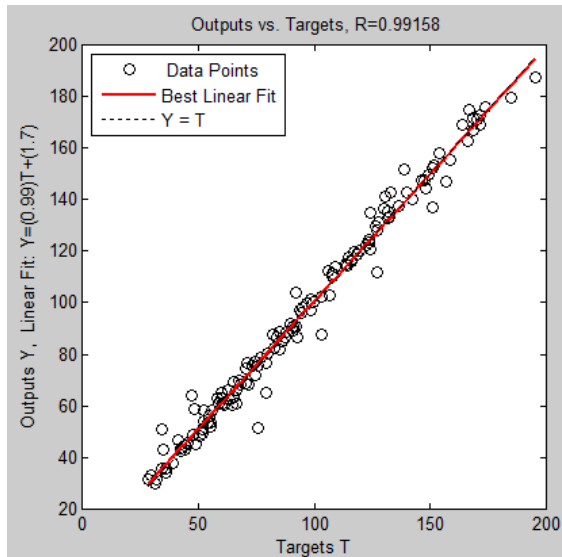

Figure 14. Regression coefficient obtained using the HTLog-sigmoid transfer function

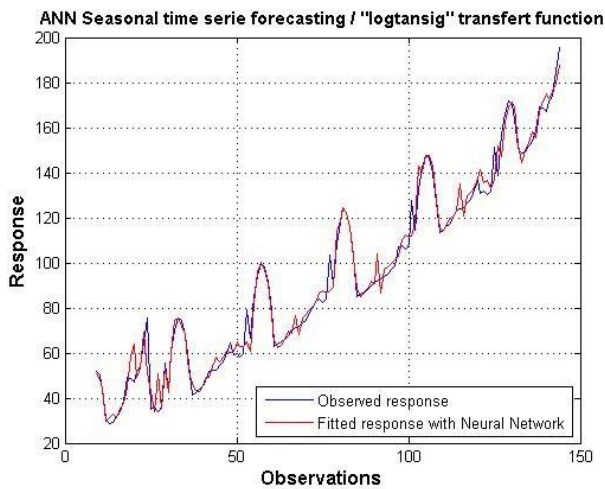

Figure 15. The response obtained with the HTLog-sigmoid function

4.4 Discussion of the Results

With eight neurons in the input layer and four neurons in the hidden layer, the neural network developed in this study gives good forecasting results for the seasonal time series. The LM learning algorithm gives better performance in terms of execution speed and forecast quality.

The comparison between the different transfer functions tested with the LM algorithm, allows to conclude that the implementation of a sigmoid (symmetrical or not) at the level of the neurons of the hidden layer, and a linear function for the neuron located in the output layer gives generally better results.

The transfer function designed in this work gives results that exceed the accuracy given by standard transfer functions and thus improves the performance and accuracy of the predictions.

5. Conclusions

In the current context of a competitive market, companies are more and more obliged to carry out an effective management of their logistic chains through an optimal planning and management of the demand. Among all logistics activities, inventory is an important component affecting the cost of industrial systems. The planning of warehouses and the maintenance of stocks depend on the estimation of the orders expected by the customers for a given period. In this work, the data used to simulate a seasonal time series representing the demand is generated by adding the three components: cycle trend TS, seasonal component S and irregularity IR.

To forecast this series, an artificial neural network model was used. After estimating the first parameters related to the neural network architecture, we proceeded to the examination of several transfer functions at the hidden layer.

The results confirm that the use of a sigmoid in the neurons of the hidden layer and a linear transfer function at the output layer generally gives good results in forecasting time series. In this study we have developed a new scheme of a transfer function that inherits its form from two sigmoids (logistic and hyperbolic tangent) widely used in neural networks to approximate nonlinear problems such as time series.

The results obtained with this function named here HTLog-Sigmoid show that they exceed those obtained using the usual transfer functions. We wish to improve this work by using a large class of time series generated by simulation, and thus show the validity domain of this model.

References

- [1] A. A. Syntetos and J. E. Boylan. On the bias of intermittent demand estimates. *International Journal of Production Economics*, 71(1) :457-466, 2001.
- [2] A. Bacchetti and N. Babbie. Spare parts classification and demand forecasting for stock control: Investigating the gap between research and practice (1991), (6):722-737, (2012). *Special Issue on Forecasting in Management Science*.
- [3] A. Bakchir and J. E. Boylan, "The accuracy of intermittent demand estimates," *International journal of Forecasting*, Vol. 21, no.2, pp. 303-314, (2005).

- [4] A. Candel, V. Parmar, E. LeDell, and A. Arora, *Deep Learning*, United States of America, (2018). A. Syntetos, *Forecasting of intermittent demand*, Brunel University, (2000). Berlin, Heidelberg, 2nd edition, 2018.
- [5] C. Croston, “Exponential forecasting: some new variations,” *Management Science*, vol. 12, pp. 311–315, 1969.
- [6] C. Li and A. Lim, “A greedy aggregation-decomposition method for intermittent demand forecasting in fashion retailing,” *European Journal of Operational Research*, vol. 269, no. 3, pp. 860–869, (2018).
- [7] Chen, K.Y. 2011. Combining linear and nonlinear model in forecasting tourism demand. *Expert Systems with Applications*, Vol.38, p 10368–10376.
- [8] D. Gopika and B. Azhagusundari, “An analysis on ensemble methods in classification tasks,” *International Journal of Advanced Research in Computer and Communication Engineering*, vol. 3, no. 7, pp. 7423–7427, (2014).
- [9] G. Kushwaha, “Operational performance through supply chain management practices,” *International Journal of Business and Social Science*, vol. 217, pp. 65–77, (2012).
- [10] G. Song and Q. Dai, “A novel double deep ELMS ensemble system for time series forecasting,” *Knowledge-Based Systems*, vol. 134, pp. 31–49, (2017)
- [11] Grewal, A. L. Roggeveen, and J. Nordfält, “The Future of Retailing,” *Journal of Retailing*, vol. 93, no. 1, pp. 1–6, (2017).
- [12] H. Biedermann. *Ersatzteilmanagement: E- Ziente Ersatzteillogistik fur industrieunteren* H. Tong, B. Liu, and S. Wang, “Software defect prediction using stacked denoising autoencoders and twostage ensemble learning,” *Information and Software Technology*, vol. 96, pp. 94–111, (2018).
- [13] K. Yeo. Model-free prediction of noisy chaotic time series by deep learning. *Computing Research Repository*, abs/1710.01693, 2017.
- [14] Kesten C. Green, J. Scott Armstrong 2012. *Demand Forecasting Evidence-basedMethods*. <https://marketing.wharton.upenn.edu/profile/226/printFriendly>.
- [15] Mitrea, C. A., Lee, C. K. M., WuZ. 2009. A Comparison between Neural Networks and Traditional Forecasting Methods: A Case Study”. *International Journal of Engineering Business Management*, Vol. 1, No. 2, p 19-24.
- [16] Shuai Wang, Lean Yu, Ling Tang, Shouyang Wang, 2011. A novel seasonal decomposition based least squares support vector regression ensemble learning approach for hydropower consumption forecasting in China. *Energy* Vol.36, p. 6542-6554.
- [17] T. R. Willemain, C. N. Smart, and H. F. Schwarz. A new approach to forecasting intermittent demand for service parts inventories. *International Journal of Forecasting*, 20(3) :375 387, 2004.
- [18] Wilamowski B. M. 2011. *Neural Network Architectures*. *Industrial Electronics Handbook*, vol. 5 – *Intelligent Systems*, 2nd Edition, chapter 6, pp. 6-1 to 6-17, CRC Press.