

ARTICLE

Environmental Strategies for Sustainable Development: An Analysis of the Drivers of Proactive Environmental Strategies in the Manufacturing Sector

Arun Kumar Vishwakarma^{1*}  Arvind K Nema²

1. National Institute of Industrial Engineering, Vihar Lake Road, Mumbai, India

2. Indian Institute of Technology Delhi, New Delhi, India

ARTICLE INFO

Article history

Received: 24 May 2022

Revised: 30 June 2022

Accepted: 1 July 2022

Published Online: 8 July 2022

Keywords:

Environmental proactiveness

Cement sector

Statistical analysis

Confirmatory factor analysis

Structural equation modelling

ABSTRACT

Stakeholders' concern towards the ecological damage arising out of emissions from the industrial processes has raised serious issues before the industrial sectors. Environmentalists and researchers are raising these issues in various forums. Few industrial sectors are well informed about environmental protection and act accordingly to address these issues by complying with environmental norms. However, some firms are more ethical in their business and proactively redefine their operations and policies beyond the regulatory requirements. What factors compel these firms to go beyond the extant laws to protect the environment? This study statistically analyses India's cement sector for the factors that may be the drivers of environmental proactivity. Using Structural Equation Modelling (SEM), eight hypotheses were tested. The study's findings can be helpful for the policymakers, environmental managers, and industrial sectors to frame policies for environmental protection, which will redound to societal benefit.

1. Introduction

Worldwide the cement sector is considered to be an emissions-intensive sector. It is known to contribute significantly to environmental damage. There is always a conflict of interest between environmentalists and cement manufacturing firms. However, due to persistent protests and opposition from society, the firms are forced to look towards emission reduction from their operations. Firms

follow the regulatory norms to protect their business interests. In the era of compliance, several firms are seen to go beyond the regulatory requirements and adopt environmental policies which are beyond the requirement of law. Such firms which are more proactive towards environmental protection are considered to follow ethics in their business policies. These firms can do so by refining their manufacturing processes to reduce the environmental footprint for environmental conservation ^[1,2]. There is a growing

*Corresponding Author:

Arun Kumar Vishwakarma,

National Institute of Industrial Engineering, Vihar Lake Road, Mumbai, India;

Email: vishwakarma71@yahoo.com; arunv1971@gmail.com; vishwakarma@nitie.ac.in

DOI: <https://doi.org/10.30564/mmpp.v4i2.4742>

Copyright © 2022 by the author(s). Published by Bilingual Publishing Co. This is an open access article under the Creative Commons Attribution-NonCommercial 4.0 International (CC BY-NC 4.0) License. (<https://creativecommons.org/licenses/by-nc/4.0/>).

trend of firms that adopt environmental management system for improving their environmental performance based on their manufacturing activities^[3-5]. This paradigm shift towards environmental conservation has drawn the attention of researchers. Factors accountable for such a shift in approach may include emissions concern, reputation, environmental policy, brand advantage, technological innovation, stakeholders' concern and waste reduction^[6,7]. Environmental innovations apart, product and process innovations can also be distinct areas^[8-10]. De Oliveira et al.^[11] report that through emissions and waste minimisation, firms could draw financial benefits. Firms are ready to make a progressive investment in efforts to protect the environment^[12]. The quantum of investment involved in activities related to the protection of the environment has made it imperative to include it in their environmental policies^[13]. Incorporation of environmental management plan leads to sustainable competitive advantage^[14]. Some researchers argue that process innovation and brand differentiation as a part of proactive environmental strategy can lead to performance enhancement^[15,16]. Firms adopt various strategies to reduce and control emissions^[17-19]. According to studies by Gunarathne & Lee^[20] and Wagner & Schaltegger^[21], better corporate environmental management and competitive advantage is observed by the firms through the adoption of environmental strategies and environmental management accounting systems. The commitment and opinion of lead managers and environmentally proactive firms result in better competitive advantage^[15,22].

The cement sector is a key sector contributing to the development of infrastructure of a developing country. Cement is the preferred construction material for all construction-related activities like housing, industrial, ports, roads, power plants, etc. The Indian cement sector has competed with global manufacturers with respect to cost control and continuous technology up-gradation. The cement industry in India is high energy intensity oriented and is the third-largest user of coal in the country. The modern cement plants use the latest technology available in the global cement industry. Due to the sufficient availability of raw material, i.e., limestone, cement plants are commissioned throughout the country. Cement production first started in India in 1914, when a single plant of 1000 tonnes per annum was commissioned in western India. With rapid infrastructure growth, India became the second-largest producer of cement in the world after China. Presently there are around 81 cement companies with 206 major cement manufacturing plants with a total capacity of approximately 360 million tonnes per annum.

Very few sectors specific studies are available which

are related to the Asian region. Though the outcome of the earlier studies is beneficial, however, they cannot be generalised to the Indian subcontinent. The study intends to identify the drivers which compel the firms to adopt environmental proactivity. The study depends on a survey-based questionnaire to get the response from 310 respondents who are working in the cement sector at various levels. The data obtained is analysed statistically using Exploratory Factor Analysis (EFA) initially, followed by Confirmatory Factor Analysis (CFA). The study proposes eight hypotheses and tests them statistically using Structural Equation Modelling. The SEM supports all the hypotheses. The organisation of the paper is as follows; an introduction is given in section 1, followed by a literature review and hypotheses development in section 2. Research significance and objectives are mentioned in section 3. Section 4 includes the research design and methodology. Results are depicted in section 5, followed by conclusions, which include discussion along with limitations and scope for future study.

2. Literature Review and Hypotheses Development

2.1 Environmental Proactiveness

Under environmental proactiveness, firms adopt environmental strategies which are beyond the compliance requirement of regulatory authority but differ from over compliance^[23]. The firms seek to follow the government regulations under over-compliance but deliver more than legal obligation on account of technological indivisibilities. Firms intentionally intend to deliver more than the regulatory requirement. Such strategies are termed as "proactive environmental strategies (PES)". Some researchers studied the "contribution of the firms' characteristics to describe the adoption of 'beyond compliance' strategies" along with "the influence of organisational context and design"^[24-27]. Organisational learning is considered by other researchers^[28]. Some studies, while concentrating on an individual or managerial level, analysed the role of leadership values and attitudes of environmental managers towards environmental proactiveness^[25,29]. Even though several studies are available, there is a lot required to be understood regarding the circumstances which describe the environmental proactiveness and are beyond the requirement of regulatory compliance^[30].

2.2 Research Hypotheses

The study attempts to identify drivers responsible for the environmental proactiveness of the cement sector firms in India.

Based on the literature review and the experts' opinions, the study proposes eight hypotheses:

Technological Innovation

Technological innovation is a crucial prerequisite for achieving sustainable development. The early 1990s witnessed the initiation of greater global awareness for sustainable development, which considered industrial environmentalism as an acceptable approach for enhancing the environmental efficacy of the technological systems^[31]. Ehrlich & Holdren^[32] advocated that technological innovation remains the only alternative to reduce the environmental impact of industrial processes. It is crucial to understand the contribution and relationship of technological innovation and environmental proactiveness. Reduced costs and enhanced product quality may be the reason for the adoption of technological innovation. Technological innovations that do not combine environmental and economic gains may not be preferred. There is always pressure on the firms to reduce the harmful effect of their product. As defined by Green et al.^[33] environmental technological innovation is "inventing, innovating and diffusing new sets of products and processes which somehow or other are inherently more environmentally friendly than the sets we currently make and use".

The following hypothesis is based on the above discussion:

H1: Technological innovation is positively associated with environmental proactiveness.

Environmental stewardship

Environmental stewardship refers to actions involving creation of protected areas, replantation, sustainable consumption, pollution prevention, afforestation, and consumption of sustainable products^[34]. There is a considerable increase in the number of companies, infrastructure owners, industrial sectors, research personnel, and communities following sustainable development globally^[35]. There is a considerable creative effort to amalgamate economic affluence with guaranteed environmental protection along with better quality of life for the current and future generations. The demand for promoting enhanced human-environment interfaces through stewardship is persistent, which includes both rural and urban land, water, and aerial environments^[36-39]. Action to steward the environment at various levels, including individual, environmental groups, corporate, and the government, is being promoted globally. Environmental stewardship also means reducing the environmental impact of the product, restoration of degraded ecology, introducing products

with low carbon footprints etc.

Based on the above discussion, the following hypothesis is proposed:

H2: Environmental stewardship is positively associated with environmental proactiveness.

Corporate environmental policy

The role of companies is crucial in minimising global environmental impact^[40] if they monitor the environmental damages caused due to their production processes^[41,42]. According to Aragón-Correa & Sharma^[43], "a strategy to manage the interface between its business and the natural environment." Companies desirous of reducing environmental damage are expected to be aware of the practical implications of environmental management^[44].

Firms having a defined environmental policy expect a possible reprieve from the regulators which can be beneficial for the firm and may become a regular part of their environmental management plan^[45]. Regulatory authorities may find such practices meaningful if such firms are performing environmentally better than their counterparts. Analysing the improved environmental performance of such firms through the adoption of Environmental Management System (EMS) and making it a benchmark in the field would be an interesting idea^[46].

The above argument gives rise to the following hypothesis:

H3: Corporate environmental policy is positively associated with environmental proactiveness.

Tackling future environmental liabilities effectively

Firm's survival and market success are dependent on the ability of its managers to foresee the future environmental liabilities and tackle pressure from various stakeholders like governments and regulatory bodies, consumers, raw material suppliers, shareholders, employee unions, financial institutions, and local communities along with competitors^[47-49].

By anticipating the stakeholders' opposition to the environmental damage due to their manufacturing activities, the firms implemented proactive environmental management plans. These plans included measures for pollution and waste reduction beyond regulatory requirements, followed by the adoption of total quality management to reap financial benefits because of business opportunities^[50]. As a second bottom line, a growing number of firms are observed to follow transparent environmental reporting^[51]. Even though the quantified effects of environmental damage may not be ascertained, it would be difficult for the firms to overlook them^[52].

Following hypothesis is proposed based on the above discussion:

H4: Tackling future environmental liabilities effectively is positively associated with environmental proactiveness.

Product and brand differentiation

It is imperative to state that the companies cannot continue to justify their dependence on a protective and unresponsive strategy considering emerging environmental market pressures and innovation potentials. Product differentiation and cost leadership must be integrated as offensive and/or innovative strategies with their corporate strategies^[53]. Environmental product and brand differentiation is a straightforward idea, i.e., to create products having higher environmental benefits or having lesser environmental costs as compared to analogous products in the market.

Brand management has emerged as a continuing vigorous activity that involves sustainability as an aspect^[54]. Several authors recommend planned actions related to marketing like innovative product design, a product with a low carbon footprint, environmentally friendly packaging etc.^[55,56]. Due to increased consumer awareness of environmental issues, the green brand image of the firm becomes an advantage. It has several advantages like avoiding disruptions in business activities, protests related to environmental damage, and penalties. It also helps in gaining customers' confidence and satisfaction related to environmentally friendly products. Minimising the use of fossil fuels and adopting renewable energy sources can help the cement sector companies in positioning themselves as protectors of the environment by minimising emissions.

Above discussion leads to the following hypothesis:

H5: Product and brand differentiation are positively associated with environmental proactiveness.

Prior assessment of future environmental legislation

Environmental SWOT (strength, weakness, opportunities, threats) analysis can be helpful for the firms in identifying external threats like future environmental legislations and relating them to internal strengths like research and development capabilities for clean processes, green products and trained human resources and opportunities (e.g. eco-friendly products and better process efficiency) along with weakness (e.g. inefficient waste management and non-recyclable products)^[57]. Prior assessment of future environmental legislation can ensure the efficient address of environmental issues along with better posi-

tioning as compared to competitors.

Firms can plan remedial action through pollution and waste reduction if they assess in advance any environmental legislation proposed to be introduced by the regulatory authority^[50]. Thus prior assessment ensures a beneficial position as compared to ill-prepared competitors. The firms capable of developing expertise related to environmental management can use it to reduce the environmental impact of their products^[58]. Waste reduction can lead to financial benefits. The expertise developed by the firms may lead to a sustainable competitive advantage over the competitors^[59].

The proposed hypothesis is based on the above discussion:

H6: Prior assessment of future environmental legislation is positively associated with environmental proactiveness.

Consumer awareness

The cost of production of green products is higher than conventionally produced products, resulting in higher selling price^[60]. Willingness of consumers to pay a higher price as a premium to cover higher production costs may prevent the government from subsidising producers of green products^[61]. However, in the absence of any subsidy, it would be difficult to find a market for green products. Thus the only option that remains is consumer awareness of environmental protection. Consumers willing to pay a higher cost for green products will encourage the firms' to adopt environmental management policies.

The emergence of global environmental concerns about ozone depletion, greenhouse gases, and climate change has presented businesses with the threat of coordinated intern action that could cause severe disruption to markets^[62,63]. Green products from popular and renowned firms always find favour among consumers^[64]. Consumers purchasing green products do not like products that cause environmental damage. Due to the preference for green products from consumers, the demand for eco-friendly products is on the rise^[65]. Considering the consumers' environmental awareness, the firms are interested in launching more and more eco-friendly products^[66]. Consumers tend to assess the specific green product rationally and honour its impact on the environment^[67]. Awareness of the environment is helpful for the products which cause minimum environmental damage and are biodegradable^[68,69].

We arrive at the following hypothesis based on the above arguments:

H7: Consumer awareness is positively associated with environmental proactiveness.

Cost saving and liability reduction

Noncompliance with environmental regulations may result in legal and ethical crises, which can be very expensive in terms of costs and loss of reputation. Companies like 3M, DuPont, and Monsanto identify that environmental costs can be transformed into revenues through the sale of waste by-products, clean technologies, or unused pollution allowances. These proactive companies realised that effectively managing environmental costs may result in improved operational and financial performance, improved health of employees and local communities, enhanced image of the company and reduced liability towards environmental damage^[70].

Effective supply chain management leads to a reduction in inventory, lead time reduction, flexibility, better forecasting, waste reduction, and precise resource planning^[71]. On the other hand, implementing green supply chain management will lead to better raw material utilisation, efficient energy and water use, an enhanced image of the firm and a reduction in environmental burden^[72]. Environmental damage due to poor planning will lead to economic loss for the firms. Firms showing better financial performance are more concerned about the environment^[73]. Environmentally friendly firms have a better relationship with regulators and investors.

The above discussion leads to the following hypothesis:

H8: Cost saving and liability reduction are positively associated with environmental proactiveness.

2.3 Hypothesised Model

Figure 1 shows the hypothesised model.

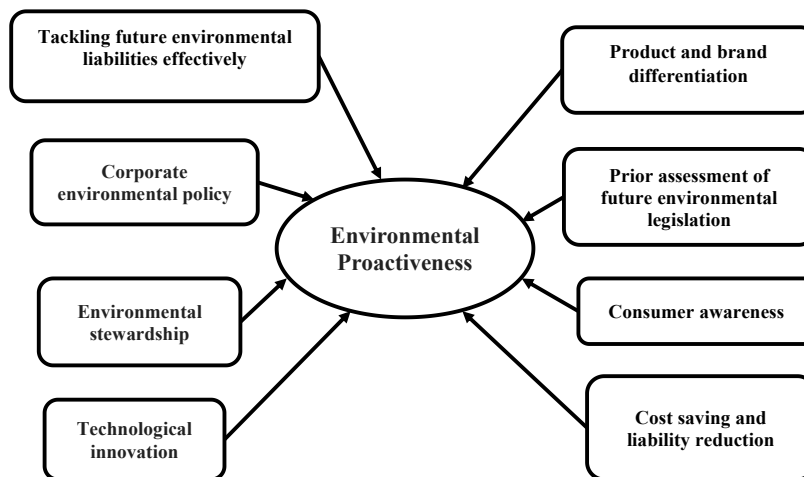

Figure 1. Hypothesised model

3. Research Significance and Objectives

The Indian cement sector is a rapidly developing sector; however, being emissions-intensive, it has always drawn the attention of environmentalists and regulatory authorities. Though policies are in place, despite that, there are several instances of violation of environmental norms. The study intends to provide evidence-based information and understanding to the policymakers and the regulatory authorities for the formulation of policies that will lead to environmental proactiveness in the cement sector. The variables selected for the study are beyond the regulatory requirement. The empirical study will help the environmental policymakers in recognising the variables considered as drivers of the environmental proactiveness of the cement sector firms. The study will be helpful in providing a meaningful understanding for the environmental managers, leaders in the business, policymakers, and environmentalists through evidence-based study for the formulation of persuasive environmental protection policies.

4. Research Design and Methodology

4.1 Sample and Data Collection

Primary as well as secondary sources of information are used. The primary data collection includes the questionnaire, focus group study and interviews. Annual reports form the basis of secondary data. A couple of focus group studies helped in understanding the key dimensions of the study. The study involved two interviews lasting 45-60 minutes duration. The period of the study was from May-2015 to July-2016. Work done in similar areas led to the designing of a questionnaire which was helped by interviews,

literature available along with focus group study [13,23,74]. The survey method is adopted as it helps in collecting a large number of responses in a short period. There are certain benefits of data collection through a questionnaire-based survey as it is inexpensive and less time-consuming. Both mail and self-administered questionnaires were adopted for data collection. The cement sector firms which followed regular environmental or sustainability reporting were the target respondents. 115 responses were collected initially for assessing the initial reliability. Later for further validation, 195 more responses were collected. EFA and CFA were performed on the complete sample of 310 respondents. Non-probabilistic sampling strategy combined with a snowball sampling method to select the firms for the study was adopted. A respondent is requested to suggest another similar respondent in snowballing sampling [75]. Out of the total of 310 level-wise respondents, 85 respondents were from the junior level (27.42%), 103 from the middle level (33.23%), and 122 from the senior level (39.35%). Department wise, out of total 310 respondents, 187 respondents were from the environment department (60.32%), 38 from the maintenance department (12.26%), 45 from the marketing department (14.51%), 30 from finance (9.68%), and 10 from the others (3.23%).

4.2 Questionnaire Design

The questionnaire method permits collection of a large sample of data in a short period. The study adopts the questionnaire method for data collection. Based on the pilot study validation of pre-tested data, the final questionnaire is prepared. A covering letter mentioning the purpose of the study, along with anonymity assurance to the respondents, was included in the final questionnaire. The initial section of the questionnaire contained information like name, department, and designation, along with a research brief. The eight variables for which response was collected using a seven-point Likert scale ranging from 1= strongly disagree to 7= strongly agree were included in the second section of the questionnaire. Based on the environmental management practices (EMP), the variables were named EMP1 to EMP8.

4.3 Data Analysis

The study uses the Statistical Package for Social Sciences (SPSS) version 23 for the quantitative analysis of data. Cronbach's α measures the internal consistency, that is, how closely the variables are related as a set of items. It is also considered a measure of scale reliability. Its value ranges from 0 to 1. A value closer to 1 is considered statistically significant, meaning variables measuring a specific

concept are highly correlated with each other. Cronbach's α value for the current study is 0.930, which indicates the reliability and validity of the scale. Table 1 shows the reliability analysis.

Table 1. Reliability analysis

Reliability Statistics		
Cronbach's Alpha	Cronbach's Alpha Based on Standardised Items	No. of items
0.930	0.931	8

Kaiser-Meyer-Olkin (KMO) Test measures the suitability of data for factor analysis. It also provides for the sampling adequacy for an individual item and the complete model. According to Tabachnick & Linda [76], for good factor analysis, KMO must be greater than 0.60. The study involves all analyses at 95% confidence level. 0.906 is the KMO value indicating that data is suitable for factor analysis. KMO analysis outcome is shown in Table 2.

Table 2. KMO Analysis

Kaiser-Meyer-Olkin Measure of Sampling Adequacy.	0.906
Approx. Chi-Square	2717.484
Bartlett's Test of Sphericity	df
	28
	Sig.
	0.000

Identification of latent variables using factor analysis contributes to a measured set of variables. Two factors emerge which have an Eigenvalue greater than one. The variance of 86% is represented by the two factors. Table 3 shows the variance along with the rotated sum of square loadings.

The minimum, maximum, mean, standard deviation and variance as the outcome of descriptive analysis are shown in Table 4.

Table 5 reflects the factor loadings, % variance explained, and eigenvalue of the two factors.

The model hypotheses were tested after the establishment of the proposed measurement using the Structural Equation Modelling (SEM) technique [77] using the maximum likelihood method. SEM checks for the goodness of fit for the proposed model. The hypothesised paths between the constructs are also tested using SEM. Hair et al. [77] mention that, by examining loading estimates, the stability of the measured items is confirmed. Stability, also known as measurement model validity, is observed if there is no substantial change in loadings. The present study estimates the chi-square statistics for checking 'p' value to arrive at the overall model fit.

Table 3. Total variance explained (Extraction method: Principal Component Analysis)

Component	Initial Eigenvalues			Extraction Sums of Squared Loadings			Rotation Sums of Squared Loadings		
	Total	% of Variance	Cumulative %	Total	% of Variance	Cumulative %	Total	% of Variance	Cumulative %
1	5.394	67.429	67.429	5.394	67.429	67.429	3.510	43.873	43.873
2	1.493	18.657	86.086	1.493	18.657	86.086	3.377	42.213	86.086
3	0.263	3.283	89.369						
4	0.230	2.875	92.244						
5	0.189	2.361	94.605						
6	0.176	2.197	96.802						
7	0.133	1.666	98.468						
8	0.123	1.532	100.000						

Table 4. Descriptive Statistics

	N	Range	Minimum	Maximum	Mean	Std. Deviation	Variance
	Statistic	Statistic	Statistic	Statistic	Statistic	Std. Error	Statistic
EMP1	310	6	1	7	4.24	0.118	4.317
EMP2	310	6	1	7	5.01	0.103	3.304
EMP3	310	6	1	7	4.50	0.114	3.998
EMP4	310	6	1	7	4.28	0.115	4.098
EMP5	310	6	1	7	4.11	0.105	3.395
EMP6	310	6	1	7	5.05	0.086	2.295
EMP7	310	6	1	7	5.03	0.095	2.815
EMP8	310	6	1	7	5.06	0.090	2.520
Valid N (list wise)	310						

Table 5. Factor Loadings

Factor	Description of Variable	Factor Loadings	% Variance Explained	Eigen Value
EMP4	Tackling future environmental liabilities effectively	0.924		
EMP1	Technological innovation	0.899		
EMP5	Product and brand differentiation	0.896	44%	5.394
EMP3	Corporate environmental policy	0.863		
EMP2	Environmental stewardship	0.891		
EMP8	Cost saving and liability reduction	0.885		
EMP7	Consumer awareness	0.869	42%	1.493
EMP6	Prior assessment of future environmental legislation	0.845		

5. Results

This section explains the outcome of CFA and SEM outcome. The earlier section highlighted the EFA results. According to Table 6, which shows the CFA results, significance value (p) <0 .001 is denoted by ***, i.e., the probability of occurrence of an event is different from zero. This means that the hypothesised relationship is significant.

Table 6. Regression weights

		Estimate	S.E.	C.R.	P
EMP1 ←	Environmental Proactiveness	1.000			
EMP2 ←	Environmental Proactiveness	0.495	0.048	10.344	***
EMP3 ←	Environmental Proactiveness	0.953	0.033	29.311	***
EMP4 ←	Environmental Proactiveness	0.953	0.034	28.059	***
EMP5 ←	Environmental Proactiveness	0.835	0.033	24.952	***
EMP6 ←	Environmental Proactiveness	0.444	0.040	11.055	***
EMP7 ←	Environmental Proactiveness	0.485	0.043	11.315	***
EMP8 ←	Environmental Proactiveness	0.410	0.042	9.664	***

Figure 2 and Figure 3 show the hypothesised CFA model and standardised estimate output path diagram for the hypothesised model, respectively.

Figure 2 shows the hypothesised CFA model.

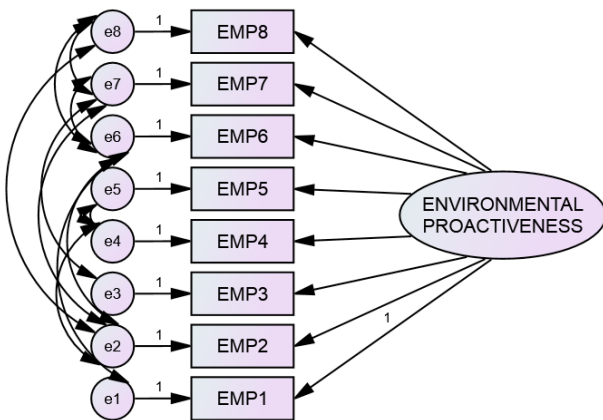

Figure 2. Hypothesised confirmatory factor analysis

Figure 3 represents the standardised estimates path diagram for the hypothesised CFA model.

Table 7 reflects the significance of estimated covariance among the latent variables, C.R. greater than 1.96 indicates factor covariance is significant. For the analysis, all

the values obtained for C.R. are greater than 1.96, which indicates the significance of factor covariance.

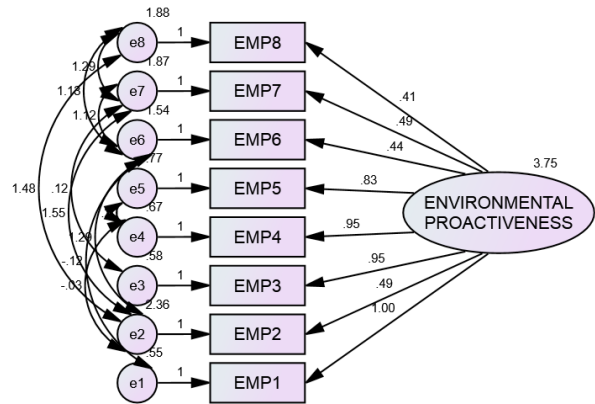

Figure 3. Standardised estimate output path diagram for the hypothesised confirmatory factor analysis model

Table 7. Variances

	Estimate	S.E.	C.R.	P
PES	3.753	0.348	10.792	***
e1	0.550	0.071	7.750	***
e2	2.363	0.195	12.149	***
e3	0.579	0.068	8.540	***
e4	0.672	0.076	8.787	***
e5	0.769	0.078	9.797	***
e6	1.538	0.129	11.966	***
e7	1.871	0.152	12.302	***
e8	1.882	0.154	12.218	***

Model fit summary, shown in Table 8, mentions the value of Cmin/df as 2.132, which specifies an acceptable fit between the hypothesised model and sample data. According to the literature, Cmin/df is acceptable if its value is less than 3. According to Chen [78], Comparative Fit Index (CFI) is a measure of the superiority of the tested model over the alternative model with a manifest covariance matrix (value ranges from 0 to 1, value nearer to 1 being more suitable). For the current analysis, CFI is 0.996; hence, it is acceptable. Normed Fit Index (NFI), a measure of the overall fit of the hypothesised model compared to the independent model, is observed as 0.992 (theoretically ranges from 0 as poor fit to 1 as perfect fit). The value of NFI obtained is acceptable. Other indicators like Goodness of Fit Index (GFI = 0.983); Adjusted Goodness of Fit Index (AGFI = 0.939) are also found to be satisfactory. Similarly, Root Mean Square Error of Approximation (RMSEA = 0.061) and Root Mean Square Residual (RMR = 0.069) values are also observed to be within permissible limits.

Table 8. Model fit summary

CMIN (Chi Square Value)	NPAR	CMIN	DF	P	CMIN/DF
	26	21.320	10	0.019	2.132
Baseline Comparisons	NFI	RFI	IFIx	TLI	CFI
	0.992	0.977	0.996	0.987	0.996
RMR (Root Mean Square Residual)	RMR	GFI	AGFI	PGFI	
	0.069	0.983	0.939	0.273	
RMSEA (Root Mean Square Error of Approximation)	RMSEA	LO 90	HI 90	PCLOSE	
	0.061	0.024	0.096	0.276	

Table 9 shows the results of hypotheses testing.

Table 9. Hypotheses testing

No.	Hypothesis	Significance	Supported/Not Supported
H1	Technological Innovation is positively associated with environmental proactiveness	***	Supported
H2	Environmental stewardship is positively associated with environmental proactiveness	***	Supported
H3	Corporate Environmental Policy is positively associated with environmental proactiveness	***	Supported
H4	Tackling future environmental liabilities effectively is positively associated with environmental proactiveness	***	Supported
H5	Product and brand differentiation is positively associated with environmental proactiveness	***	Supported
H6	Prior assessment of future environmental legislation is positively associated with environmental proactiveness	***	Supported
H7	Consumer awareness is positively associated with environmental proactiveness	***	Supported
H8	Cost saving and liability reduction is positively associated with environmental proactiveness	***	Supported

*** highly significant at $p < 0.001$

6. Conclusions

6.1 Discussion of Results

The Indian cement sector has metamorphosed from a single cement manufacturing plant in the early 1950s to the globally second-largest producer. The sector has witnessed a major transition from energy-consuming wet process kilns to energy-efficient dry process kilns. Over a period of time, the Indian cement sector shed the image of being a state monopoly to multinational companies' domain. The presence of these firms ensured the availability of the latest technology. The cement manufacturing process being emissions-intensive has drawn severe criticism from environmentalists and other stakeholders. The environmental regulatory authority has implemented strict

compliance norms for the sector. The violators are penalised in the form of fines or business disruptions.

As business disruption invites loss of reputation for the firms, they do not hesitate to walk the extra mile by adopting proactive environmental strategies which are beyond the requirement of laws. What are the drivers of such environmental proactiveness? The current study identifies these drivers which are responsible for the environmental proactiveness of cement sector firms in India. The study uses a survey-based questionnaire method to collect responses from 310 respondents. EFA is used for the initial analysis for deciding the reliability and validity of the items in the study. CFA and SEM are used for hypothesis testing. The study proposes eight hypotheses. Hypothesis H1 states that technological innovation is

positively associated with environmental proactiveness. The analysis supports the hypothesis. Earlier, Graedel & Allenby^[31] have identified that technological innovations are an essential requirement for sustainable development. Hypothesis H2 finds environmental stewardship as a driver of environmental proactiveness. Several studies^[79,80] observe environmental stewardship as a trade-off between efficiency and resilience with short and long-term financial benefits. A defined corporate environmental policy is always beneficial for the firm in terms of getting relief from the regulatory authority while adopting environmental management systems^[45]. Thus the analysis outcome which supports hypothesis H3 is correct. Firms must take precautionary steps to tackle future environmental liabilities effectively. This act will ensure uninterrupted business activities even with fresh regulatory requirements. Rondinelli et al.^[50] identified that firms who take the initiative in anticipating ecological damage due to their operations and take preventive actions benefit from such decisions. Thus the analysis rightly supports hypothesis H4. A firm with its green operations can create product and brand differentiation in the market. According to Porter & Linde^[15], Chen et al.^[81] and Peattie^[82], due to increased consumer awareness and strict environmental norms, firms having a green brand image can smoothly run the business. The analysis supports hypothesis H5. Advance preparedness is always better to avert any regulatory enforcement^[50]. This way, the firms can gain an advantage over their ill-prepared competitors. Specific expertise developed to reduce ecological damage can help achieve the emissions cut target^[58]. The analysis is right in supporting hypothesis H6. Growing consumer awareness of environmental conservation can benefit firms as they can influence their customers through voluntary environmental protection and introducing products with low carbon footprints^[83]. The study finds a positive association in hypothesis H7. The final hypothesis H8 proposes that cost-saving and liability reduction are positively associated with environmental proactiveness. A firm can make its operations more efficient by implementing supply chain management practices^[71]. Through green supply chain management, the firms reduce wastage of raw materials, water and energy, better their reputation and minimise their liability^[72]. The study supports hypothesis H8, which is validated by these studies.

The outcome of the study will be helpful for the decision-makers and the policymakers in the field of environmental compliance. The evidence-based findings will be useful in the formulation of ethical business policies, which will help improve not only compliance but also promote environmental proactiveness. The policymakers

can focus on policies based on the drivers mentioned in the study. Policy guidelines should favour the firms in the form of incentives that go beyond regulatory norms to make additional efforts for the conservation of the environment. The firms who are environmentally proactive may use such incentives for brand and image development, which down the line will pave the way for the other firms to follow.

6.2 Limitations and Scope for the Future Study

In spite of several advantages, there are some limitations to the study. Can the findings be applied to other countries which have similar political and socio-economic structures? There may be potential bias, even though due care was taken to design and conduct the study. There may be a difference in vertical integration level across the environmental policies for other industries, which requires investigation. The environmental implications may also be different from different operations. Such differences need to be compared. The cement sector is a combination of small and big firms. Whether all the firms show similar behaviour or not will be an interesting future study. Findings may also be applied to other industrial sectors. Another study can examine the effect of regulatory capacity and its ability to enforce regulations with implications on environmental strategies of the firms due to the institutional regulatory structure.

Conflict of Interest

There is no conflict of interest.

References

- [1] Reid, A., Miedzinski, M., 2008. Eco-innovation: Final Report for Sectoral Innovation Watch. Technopolis Group, Brighton.
- [2] OECD, 2009. Sustainable manufacturing and eco-innovation: framework. Practices and Measurement–Synthesis Report. OECD, Paris.
- [3] Carruthers, G., Vanclay, F., 2012. The intrinsic features of Environmental Management Systems that facilitate adoption and encourage innovation in primary industries. *Journal of Environmental Management*. 110, 125-134.
- [4] Liu, X., Liu, B., Tomohiro, S., et al., 2010. An empirical study on the driving mechanism of proactive corporate environmental management in China. *Journal of Environmental Management*. 91, 1707-1717.
- [5] Prajogo, D., Tang, A.K.Y., Lai, K., 2012. Do firms get what they want from ISO 14001 adoption? : An Australian perspective. *Journal of Cleaner Produc-*

- tion. 33, 117-126.
- [6] Bansal, P., Roth, K., 2000. Why companies go green: a model of ecological responsiveness. *Academy of Management Journal*. 43(4), 717-736.
- [7] Banerjee, S.B., Iyer, E.S., Kashyap, R.K., 2003. Corporate environmentalism: antecedents and influence of industry type. *Journal of Marketing*. 67(2), 106-122.
- [8] OECD and Eurostat, 1997. Proposed Guidelines for Collecting and Interpreting Technological Innovation Data-Oslo-Manual. OECD/Eurostat, Paris.
- [9] Rehfeld, K.M., Rennings, K., Ziegler, A., 2007. Integrated product policy and environmental product innovations: an empirical analysis. *Ecological Economics*. 61(1), 91-100.
- [10] Ziegler, A., Rennings, K., 2004. Determinants of environmental innovations in Germany: do organisational measures matter? Discussion Paper No. 04-30. ZEW, Mannheim.
- [11] De Oliveira, O.J., Serra, J.R., Salgado, M.H., 2010. Does ISO 14001 work in Brazil? *Journal of Cleaner Production*. 18, 1797-1806.
- [12] Chan-Fishel, M., 2002. Survey of climate change disclosure in SEC filings of automobile, insurance, oil and gas, petrochemical and utilities companies. Friends of the Earth-U.S.
- [13] Christmann, P., 2000. Effects of "best practices" of environmental management on cost advantage: the role of complementary assets. *Academy of Management Journal*. 43(4), 663-680.
- [14] Clarkson, P.M., Li, Y., Richardson, G.D., et al., 2011. Does it really pay to be green? Determinants and consequences of proactive environmental strategies. *Journal of Accounting and Public Policy*. 30, 122-144.
- [15] Porter, M., van der Linde, C., 1995. Toward a new conception of the environment-competitiveness relationship. *Journal of Economic Perspectives*. 9(4), 97-118.
- [16] Hart, S.L., 1995. A natural resource-based view of the firm. *Academy of Management Review*. 20(4), 986-1014.
- [17] Frosch, R., Gallopoulos, N., 1989. Strategies for manufacturing, *Scientific American*. pp. 144-152.
- [18] Cairncross, F., 1991. *Costing the Earth*, Harvard Business School Press, Boston.
- [19] Willig, J., (Eds.), 1994. *Environmental TQM*, McGraw-Hill, New York.
- [20] Gunarathne, N., Lee, K.H., 2015. Environmental Management Accounting (EMA) for environmental management and organisational change. *Journal of Accounting & Organizational Change*. 11(3), 362-383.
- [21] Wagner, M., Schaltegger, S., 2004. The effect of corporate environmental strategy choice and environmental performance on competitive and economic performance: an empirical study of EU manufacturing. *European Management Journal*. 22(5), 557-572.
- [22] Spencer, S.Y., Adams, C., Yapa, P.W.S., 2013. The mediating effects of the adoption of an environmental information system on top management's commitment and environmental performance. *Sustainability Accounting, Management and Policy Journal*. 4(1), 75-102.
- [23] Prakash, A., 2001. Why do firms adopt 'beyond compliance' environmental policies? *Business Strategy and the Environment*. 10, 286-299.
- [24] Ramus, C.A., Steger, U., 2000. The Roles of Supervisory Support Behaviors and Environmental Policy in Employee "Eco-initiatives" at Leading-Edge European Companies. *Academy of Management Journal*. 43(4), 605-626.
- [25] Sharma, S., 2000. Managerial interpretations and organisational context as predictors of corporate choice of environmental strategy. *Academy of Management Journal*. 43, 681-697.
- [26] Sharma, S., Pablo, A.L., Vredenburg, H., 1999. Corporate environmental responsiveness strategies: the importance of issue interpretation and organisational context. *Journal of Applied Behavioural Science*. 35, 87-108.
- [27] Smart, B., (Ed.). 1992. *Beyond Compliance: a New Industry View of the Environment*, World Resources Institute, Washington.
- [28] Marcus, A.A., Nichols, M.L., 1999. On the edge: heeding the warnings of unusual events. *Organisation Science*. 10, 482-499.
- [29] Egri, C., Herman, S., 2000. Leadership in the North American environmental sector: Values, leadership styles, and contexts of environmental leaders and their organisations. *Academy of Management Journal*. 43, 571-604.
- [30] Delmas, M.A., Toffel, M.W., 2004. Institutional pressure and environmental management practices. S Sharma, M Starik (Eds.), *Stakeholders, the Environment, and Society*: 230-245. Edward Elgar Publishing: Northampton, MA.
- [31] Graedel, T.E., Allenby, B.R., 1995. *Industrial Ecology*. Prentice Hall, Englewood.
- [32] Ehrlich, P.E., Holdren, J.P., 1972. Impact of population growth. Ridker RG (ed) *Population, resources and the environment*. US Government Printing Of-

- rice, Washington. pp. 365-377.
- [33] Green, K., McMeekin, A., Irwin, A., 1994. Technological Trajectories and R&D for Environmental Innovation in UK Firms. *Futures*. 26(10), 1047-1059.
- [34] Bennett, N.J., Whitty, T.S., Finkbeiner, E., et al., 2018. Environmental Stewardship: A Conceptual Review and Analytical Framework. *Environmental Management*. 61, 597-614.
DOI: <https://doi.org/10.1007/s00267-017-0993-2>
- [35] Placet, M., Anderson, R.G., Fowler, K.M., 2005. Strategies for Sustainability. *Research Technology Management*. 48(5), 32-41.
- [36] Allsopp, M., Page, R., Johnston, P., et al., 2009. *State of the world's oceans*. Springer, New York, NY.
- [37] Díaz, S., Demissew, S., Carabias, J., 2015. The IP-BES conceptual framework — connecting nature and people. *Current Opinion in Environmental Sustainability*. 14, 1-16.
- [38] Davy, C.M., Ford, A.T., Fraser, K.C., 2017. Aero conservation for the fragmented skies. *Conservation Letters*.
DOI: <https://doi.org/10.1111/conl.12347>
- [39] Rockström, J., Steffen, W., Noone, K., 2009. A safe operating space for humanity. *Nature*. 461, 472-475.
DOI: <https://doi.org/10.1038/461472a>
- [40] Carballo-Penela, A., Doménech, J., 2010. Managing the carbon footprint of products: the contribution of the method composed of financial statements (MC3). *International Journal of Life Cycle Assessment*. 15(9), 962-969.
DOI: <https://doi.org/10.1007/s11367-010-0230-1>
- [41] Wahba, H., 2008. Does the market value corporate environmental responsibility? An empirical examination. *Corporate Social Responsibility and Environmental Management*. 15(2), 89-99.
DOI: <https://doi.org/10.1002/csr.153>
- [42] Babiak, K., Trendafilova, S., 2011. CSR and environmental responsibility: motives and pressures to adopt green management practices. *Corporate Social Responsibility and Environmental Management*. 18(1), 11-24.
DOI: <https://doi.org/10.1002/csr.229>
- [43] Aragón-Correa, J.A., Sharma, S., 2003. A contingent resource-based view of proactive corporate environmental strategy. *Academy of Management Review*. 28(1), 71-88.
DOI: <https://doi.org/10.5465/amr.2003.8925233>
- [44] Carballo-Penela, A., Castromán-Diz, J.L., 2015. Environmental Policies for Sustainable Development: An Analysis of the Drivers of Proactive Environmental Strategies in the Service Sector. *Business Strategy and the Environment*. 24, 802-818.
DOI: <https://doi.org/10.1002/bse.1847>
- [45] Dahlstrom, K., Howes, C., Leinster, P., et al., 2003. Environmental management systems and company performance: assessing the case for extending risk-based regulation. *European Environment*. 13, 187-203.
- [46] ISO, 2004. Environmental management systems—general guidelines on principles, systems and supporting techniques (ISO 14004:2004).
- [47] González-Benito, J., González-Benito, O., 2005. A study of the motivations for the environmental transformation of companies. *Industrial Marketing Management*. 34(5), 462-475.
DOI: <https://doi.org/10.1016/j.indmarman.2004.08.005>
- [48] Freeman, R.E., 2004. *A Stakeholder Theory of Modern Corporations: Ethical Theory and Business*. Pitman: Boston, MA.
- [49] Wolf, J., 2013. Improving the sustainable development of firms: the role of employees. *Business Strategy and the Environment*. 22(2), 92-108.
DOI: <https://doi.org/10.1002/bse.1731>
- [50] Rondinelli, D.A., Berry, M.A., 1997. Industry's Role in Air Quality Improvement: Environmental Management Opportunities for the 21st Century. *Environmental Quality Management*. 7, 31-44.
- [51] Makower, J., 1993. *The E-Factor: The Bottom Line Approach to Environmentally Responsible Business*, New York: Tilden Press.
- [52] Sullivan, T.F.P., (Eds.), 1992. *The Greening of American Business-Making Bottom Line Sense of Environmental Responsibility*, Rockville, MD: Government Institutes, Inc.
- [53] Steger, U., 1993. The greening of the board room: how German companies are dealing with environmental issues. Fischer, K. and Schot, J. (Eds), *Environmental Strategies for Industry*, Island Press, Washington, DC. pp. 147-166.
- [54] Louro, M.J., Cunha, P.V., 2001. Brand management paradigms. *Journal of Marketing Management*. 17(7,8), 849-875.
- [55] Keller, K.L., 2003. *Strategic Brand Management*. New Jersey, Prentice Hall, Pearson, Education Inc.
- [56] Merz, M., He, Y., Vargo, S.L., 2009. The evolving brand logic: A service-dominant logic perspective. *Journal of the Academy of Marketing Science*. 37(3), 328-344.
- [57] Padash, A., Ghatari, A.R., 2020. Toward an innovative green strategic formulation methodology: empowerment of corporate social, health, safety and

- environment. *Journal of Cleaner Production*. 261, 121075.
DOI: <https://doi.org/10.1016/j.jclepro.2020.121075>
- [58] Schmidt, S.T., Schneider, M., Hoffman, V., 2012. Decarbonising the power sector via technological change – differing contributions from heterogeneous firms. *Energy Policy*. 43, 466-479.
- [59] Ghemawat, P., 1991. *Commitment*, Free Press, New York.
- [60] Conrad, K., 2005. Price competition and product differentiation when consumers care for the environment. *Environment and Resource Economics*. 31, 1-19.
- [61] Moon, W., Florkowski, W.J., Brückner, B., et al., 2002. Willingness to pay for environmental practices: Implications for eco-labelling. *Land Economics*. 78(1), 88-102.
- [62] Haas, P.M., Keohane, R.O., Levy, M.A., (Eds.), 1993. *Institutions for the earth: Sources of effective international environmental protection*. Cambridge, MA: MIT Press.
- [63] Rowlands, I.H., 1995. *The politics of global atmospheric change*. Manchester: Manchester University Press.
- [64] Suki, M.N., 2013. Green Awareness Effects on Consumer Purchasing Decision. *Penerbit*. 9(2), 49-62.
- [65] Wahid, N.A., Rahbor, E., 2011. Investigation of Green Marketing Tools Effect on Consumer's Purchase Behavior. *Business Strategy*. 12(2), 73-83.
- [66] Shruti, P.M., 2014. Awareness of Green Marketing and Its Influence on Buying Behavior of Consumers: Special Reference to Madhya. *AIMA Journal of Management & Research*. 8(1/4).
- [67] Prakash, A., 2002. Green Marketing, Public Policy and Managerial Strategies. *Business Strategy & the Environment*. 11(5), 285-297.
DOI: <https://doi.org/10.1002/bse.338>
- [68] Borin, N., Lindsey-Mullikin, J., Krishnan, R., 2013. An Analysis of Consumer Reactions to Green Strategies. *Journal of Product & Brand Management*. 22(2), 118-128.
- [69] Tiwari, S., Tripathi, D.M., Srivastava, U., et al., 2011. Green Marketing - Emerging Dimensions. *Journal of Business Excellence*. 2(1), 18-23.
- [70] Berry, M.A., Rondinelly, D.A., 1998. Proactive corporate environmental management: A new industrial revolution. *Academy of Management Executive*. 12(2), 38-50.
- [71] Koh, S.C.L., Demirbag, M., Bayraktar, E., et al., 2007. The impact of supply chain management practices on performance of SMEs. *Industrial Management and Data Systems*. 107(1), 103-124.
- [72] Wisner, J.D., Tan, K.C., Leong, G.K., 2012. *Supply chain management: a balanced approach*. 3rd ed. Canada: South-Western Cengage Learning.
- [73] Flammer, G., 2013. Corporate social responsibility and shareholder reaction: the environmental awareness of investors. *Academy of Management Journal*. 56(3), 758-781.
- [74] Aragón-Correa, J.A., 1998. Strategic proactivity and firm approach to the natural environment. *Academy of Management Journal*. 41(5), 556-567.
- [75] Tran, V.M., Perry, J.A., 2003. Challenges to using neem (*Azadirachta indica* var. *Sinensis* Valenton) in Thailand. *Economic Botany*. 57(1), 93-102.
- [76] Tabachnick, B., Linda, S., 2012. *Using multivariate statistics*: Pearson Education, Limited.
- [77] Hair, J., Black, W., Babin, B., et al., 2010. *Multivariate Data Analysis. A Global Perspective*: Pearson Prentice Hall.
- [78] Chen, F.F., 2007. Sensitivity of goodness of fit indexes to lack of measurement invariance. *Structural Equation Modelling*. 14(3), 464-504.
- [79] Liu, J., 2007. Complexity of coupled human and natural systems. *Science*. 317, 1513-1516.
- [80] Kareiva, P., Chang, A., Marvier, M., 2008. Development and conservation goals in World Bank projects. *Science*. 321, 1638-1639.
- [81] Chen, Y.S., Lai, S.B., Wen, C.T., 2006. The Influence of Green Innovation Performance on Corporate Advantage in Taiwan. *Journal of Business Ethics*. 67(4), 331-339.
- [82] Peattie, K., 1995. *Environmental Marketing Management* (Pitman Publishing Corp., London, UK).
- [83] Khanna, M., 2001. Non-mandatory approaches to environmental regulation: a survey. *Journal of Economic Surveys*. 15(3), 291-324.