

REVIEW

A Parametric Approach to the Evaluation of Flexural Strength of Advanced Ceramic or Glass Like Cylindrical Rods at Ambient Temperature

Padmanabhan Krishnan*

Department of Manufacturing Engineering, School of Mechanical Engineering, VIT University, Vellore, 632014, India

ARTICLE INFO

Article history

Received: 8 October 2019

Accepted: 22 October 2019

Published Online: 30 October 2019

Keywords:

Flexure strength

Ceramics

Glasses

Fracture

Surface Finish

Length to Diameter Ratio

Flaw size

Strain

ABSTRACT

This critical review presents a parametric approach to the evaluation of flexural strength of advanced ceramic or glass like cylindrical rods at ambient temperature. The parameters governing the measurement and evaluation of flexure strengths of glasses and ceramics are detailed with references. The scope for improvement in the existing ASTM STM C -1684 standard is described with a logical rationale and the parameters that need to be addressed are listed and explained.

1. Introduction

A flexure test to measure and evaluate the strength of ceramics and glasses must have information on allowable porosities. Flaw levels in the cylindrical rod have to be prescribed for measurements sake, as there is severe emphasis in flexure testing on fracture and Weibull distributions. They depend a lot on porosity levels. When we mention whisker reinforced composites and their applicability to the testing procedures there must be a mention on whether they are random or aligned. Whisker reinforced ceramics can also be bi modular making it a

little easier for characterization. These composites cannot be isotropic if they are aligned. Randomness is closer to quasi-isotropy mostly. These issues have to be addressed if flexure testing is considered applicable to whisker reinforced composites as well. There has to be a realistic approach in the consideration of raw data and heat treated data for flaw reduction and porosity reduction as uniformity is achieved through heat treatment. The requirements and recommendations according to this publication can be followed that would make flexural strength testing more reliable and consistent.

*Corresponding Author:

Padmanabhan Krishnan,

Department of Manufacturing Engineering, School of Mechanical Engineering, VIT University, Vellore, 632014, India;

Email: padmanabhan.k@vit.ac.in

2. Parametric Approach

Grinding is an operation meant to produce a surface finish of less than $2\text{-}3\ \mu\text{m}$ ^[1]. It is a final operation that hones a surface. As porosity is taken in to account by flexure testing procedures, there should be a table on the need for a surface finish of a required fine surface roughness finish. One cannot prescribe a uniform 600 grit finish surface as in some investigations ^[2]. As the natural flaw size vs. grinding damage size matters in flexure testing as governed by the findings of fracture mechanics, the surface flaw size should be lower than the critical crack length that is required for fracture. As we know about the critical flaw size required for fracture which depends on the critical stress intensity factor and the flaw size limit in order to get a particular stress value which is reported as strength. As flexure strength depends on the flaw size and K_{Ic} in tension, the critical flaw size for most ceramics and glasses are anywhere from submicron resolution to a few microns. Some glasses can have, say 0.8 microns of critical crack size above which fracture occurs ^[3]. The contention here is that by using a 600 grit finish, one is creating a 3-5 micron crack length on the surface (any machining company brochure will do to justify this statement on the R_{max} obtainable on a ceramic for a grit size with 25-28 micron sized ceramic particles or diamond particles) ^[4] of a glass like material which has a critical crack length of a micron or lower. So, for a class of glassy materials to be evaluated for their flexure strength, the surface finish must be finer than the critical crack length that is natural to them in bulk. Virtually for a ceramic surface, the use of Silicon carbide grits is difficult. Diamond or harder ceramic particles are more suitable. A standard practice must also make enough prescription for whisker reinforced composites or other Ceramic Matrix Composites (CMCs) that may have shorter or longer critical flaws. A finer prescription on the surface finish requirements will ensure that surface conditions do not reduce the flexural strength of a specimen. It should not be allowed play a dubious role based on the flaw size vs. surface damage condition ratios. 1500 grit finish or above would create a surface with an R_{max} of less than a micron which would fulfill the requirements for testing. The allowables for support span to diameter ratios to measure flexural strength are anywhere between 2.9 to 20 in the standard STM-C 1684 for flexure testing of ceramics published by an ASTM committee ^[2]. Sufficient knowledge of compression, tension and shear in ceramics and glasses will inform an evaluator that a fixed span to diameter ratio must be agreed upon by those concerned as all ASTM standards are voluntary consensus standards. Though, every materials engineer knows that

long beams provide a closer to the elastic modulus value and shorter beams provide a lower modulus, a fixed span has not been prescribed for the flexure tests of ceramics and glasses. As shorter beams have more shear component they would provide a higher flexural strength value than a longer span specimen with the same diameter. Considering that the tensile to compressive strength ratios of cylindrical rod like ceramics and glasses are in the range of say, 150/2000 MPa, the flexural strength is higher than the tensile strength but lower than the compressive strength. It has a dependence on the span to diameter ratio also. A common span must have been prescribed for a class of materials to regulate the repeatability within a laboratory and reproducibility between laboratories. The minimum span to diameter ratio of 3 prescribed for flexure testing of ceramic/ glass cylindrical rods at a small diameter would lead to a very low strength in the vicinity of surface flaws produced by a 600 grit finish and a higher strength when finished to a sub-micron resolution using a grit number like 1500. Besides, for a small cross section, the defect population is less and the flexural strength may be more subject to a good surface finish as mentioned before. However, for a larger specimen with a span to depth ratio of about 29, the flexural strength could be lower even for the same defect population as there are more defects across the cross section and along the length. Hence, at a nominal defect population for thicker and longer specimens which would be practically higher along and across the cross section, the flexural strength could be low. In the absence of flaws one might expect the size effect to take over and larger specimens might exhibit higher flexural strength even within the present domain. One must standardize on the span. Please see Figure 1 for a schematic understanding of the test dimensions.

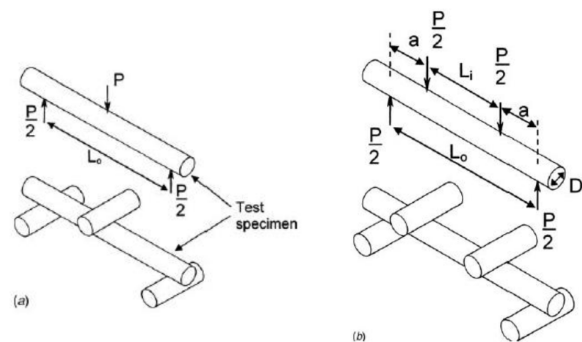

Figures 1 (a) and (b). The load (P), its distributions in the three (a) and four point (b) set up, the roller and specimen diameters and the support span lengths are marked

The effective area and effective volume calculations for test specimens concerned are not clearly spelt in the C 1684 standard for all the reasons described earlier here.

As there has been no clarity on porosities, scatter, span to diameter ratio and surface finish, any attempt to understand the variabilities in strength through statistical means is null and void. A statistical meaning would be justified only when a sound parametric approach is followed.

While discussing the crack growth rates that are important in ceramics, glasses and CMCs, the loading rates, constant cross head velocities or strain rates must be specified in a standard. A constant cross head velocity and a constant strain rate cannot be achieved simultaneously in the same test. Each one of them generates different crack growth rate(s) and fracture. Recommended constant strain rates or cross head velocities that generate an increasing strain rate as the sample nears fracture must be based on an understanding of strict domains of quasi-static or dynamic fracture. A constant cross head velocity value does not produce a constant strain rate nor can it be called one. An exponential decay of cross head velocity gives a constant strain rate when the exponent 'k' in the exponential term is adjusted to provide a constant strain rate^[5]. Experiments on the DARTEC systems by Prof. YVRK Prasad and group may be referred to. It is very important to note that the conditions change with the length, diameter and span to depth ratio in order to maintain a range of increasing strain rates at a constant cross head velocity or a constant strain rate with an exponential decay of cross-head velocity. The standard C- 1684 prescribes a strain rate evaluation formulation based on a constant cross head velocity which is erroneous. It would have been better to prescribe one of the criteria mentioned above and not confuse the researchers.

The flexure strength is higher than the tensile strength for the span: diameter ratios used in the standard C 1684. Even if a single common span is used, the results will be likewise. However, the authors of C 1684 have made the statement 'tensile strength is measured using the flexure test' in the opening statement of their JTEVA paper^[6]. (Journal of Testing and Evaluation, Vol. 37, No. 3 Paper ID JTE101649, by George D Quinn, Brian T Spareberg, Lewis K Ives, Said Jahanmir, Philip Koshy and Dwayne D Arola, on Flexural strength of glass and ceramic rods). Though the publication is by a National Institute of Standards and Technology group from Gaithersburg, USA, they have not referred to the other works from the same cradle that clearly give a lower tensile strength value to ceramics and glasses compared to their flexural strengths. It is known that it is difficult to do tensile tests for ceramics but any scaling done with the help of flexure tests must be based on sound logic. Any attempt of scaling done otherwise, will not be even precise with a margin of error, leave alone being accurate. As they say accuracy is being

bang on target and precision is how exactly far away you are from it. The JTEVA paper should have not made an opening statement on measuring tensile strength through flexure based on their given fallacies. Only flexure strength can be measured with flexure tests. Scaling must depend on size effects, span to depth/dia ratios, stress concentration effects at the roller sites, Weibull statistics and effective area and volume analyses based on the all of the above.

Further, the grain size conditions, processing history and heat treatment procedure requirements, if any, are never mentioned in the standard.

3. Casual Factors in Fracture

Some casual factors that arise in addition to the root causes in the failure of the C 1684 standard to hold itself together are the following:

(1) Rubber banding of the rollers alters the span to diameter ratio whilst the specimen is being tested. It is not a correct practice.

(2) The cradle material is not specified in the standard though it is a form of rubber. The user should not be made to guess.

(3) As flexure is compressive and tensile in a certain ratio, it is also end face dependent especially in solid cylindrical rods. The face ends on glasses, ceramics and CMCs, must have strict prescriptions on special machining of the ends. Cracks generate at the face ends due to shear and bending as the top of the specimen experiences compression and the bottom experiences tension, when bent from the top. The standard prescription for the cylindrical surface holds good for the end faces as well.

(4) No diameter tolerances have been specified for elliptical specimens which also form a part of the standard. (Like major axis and minor axis).

(5) A statement in the standard reads, 'Ave. stress less than 2.5 %' which is erroneous. The statement must be removed.

(6) Another statement reads, 'Strength to elastic modulus ratio of 1000'. Which can never be but only otherwise.

(7) The standard does not address stress concentration factors leading to fracture.

(8) Three point and four point bend test comparisons are not convincing in the standard.

(9) Valid vs. invalid failures have not been discussed properly or their outcomes and recommendations laid down properly. Some of the flaws in the standard that are pointed out here will help in clearing the picture.

(10) The NIST data that are freely available, list the tensile, flexural and compressive strengths of many ceramics and glasses. The flexural strength is always higher

than the tensile strength for these class of materials, much against the statement given in the JTEVA paper^[6].

(11) Materials like cubic boron nitride, tantalum carbide, hexaborides and the likes are advanced ceramics not alumina, SiC and the likes. Most of the data available and the test results available for the ceramics are those of basic ceramics and glasses. However, the title 'advanced ceramics' is cited in the standard for experimental work on basic ceramics.

Hence, in the author's opinion the standard STM C-1684 must be withdrawn by the persons who developed it and the committee that voted it in and revised for reconsideration. Outside experts in the field must be brought in to do a lot of work to turn this attempt in to success. After all, ASTM standards are voluntary consensus standards and should not be a product of oligarchy. A parametric approach should be followed based on a strong rationale to assist the process of reproducibility between groups.

Acknowledgement

The author thanks the management of VIT, Vellore, for the support and encouragement. The Chief Editor of Non-metallic materials Science Journal is also thanked for

the invitation to submit an article.

References

- [1] Serope Kalpakjian, Steven R Schmid, Manufacturing Processes for Engineering Materials, 5th ed., Pearson Education India, 2009.
- [2] ASTM STM C-1684- 2018, Standard Test Method for Flexural Strength of Advanced Ceramics at Ambient Temperature- Cylindrical Rod Strength , West Conshohocken ,PA, USA, 2018.
- [3] Richard L Lehman, Said K El-Rahaiby, John B Wachtman Jr., Handbook on Fiber Ceramic Composites, Purdue University, West Lafayette, IN, 1995.
- [4] www.metallographic.com
- [5] YVRK Prasad, Processing Maps: A Status Report, JI. Of Materials Engineering and Performance, December 2003, 12(6): 638-645.
- [6] George D Quinn, Brian T Sparenberg, Lewis K Ives, Said Jahanmir, Philip Koshy and Dwayne D Arola , Flexural strength of ceramic and glass rods, Journal of Testing and Evaluation, 2009, 37(3): 222-244. Paper ID JTE101649.