

REVIEW

Cashew Nut Shell Liquid (CNSL) Based Bio-Derived Resin And Composites for Advanced Structural, Automotive, Electronic Packaging and Medical applications- A Review

Padmanabhan Krishnan*

Department of Manufacturing Engineering, School of Mechanical Engineering, VIT , Vellore, 632014, India

ARTICLE INFO

Article history

Received: 16 March 2020

Accepted: 29 March 2020

Published Online: 31 March 2020

Keywords:

Cashew Nut Shell Liquid (CNSL) Resin

Hardness

Tensile Properties

DSC

Thermo Gravimetric Analysis (TGA)

Fracture toughness

Vibration damping

Natural frequencies

Di-electric Constant

Electronic packaging

Genetic modification

Waste plastics to fuel

ABSTRACT

As India is a world class producer of sugarcane, sugar beet, other tubers like potato and vegetables with starch, cashew and badam, castor oil and soybean, the quantum of bio resins and bio plastics that can be produced from these conventional, organic and genetically modified plants is immense. As on date, advanced and state of the art plastics and composites are being used in many applications as there is no incentive for farmers to produce plants and vegetables for the plastics and resins market exclusively. The use of advanced composites in varied applications escalates costs and shifts the material consumption that would deplete the natural resources, through excessive usage at one end and lack of demand for natural resources at the other end as bio derived composites become under-utilized. This review paper attempts to project the actual possibilities of the bio resin and bio plastic market in this country and provides the knowhow for the production of bio-phenolic cashew nut shell resin which are more than a substitute for the synthetically produced epoxies. Their true potentialities in composites product applications involving structural, thermal, electronic, pharmaceutical and petroleum engineering markets is discussed in this paper. A novel working model with an economically feasible option is also provided for those concerned about their safe disposal, recycling, reuse and conversion into useable fuel with virtually no impact to the environment. Cashew Nut Shell Liquid (CNSL) is an abundant natural source for synthesizing phenolic compounds. The excellent monomer, Cardanol is isolated from CNSL for polymer production. These are polymerized with aldehydes and acids at a particular mole fraction in the presence of catalysts like alkalis to convert into rigid resins. Differential Scanning Calorimetric (DSC) and Thermo Gravimetric Analysis (TGA) were studied for the thermal characterization of the synthesized CNSL Resins. Characterization of the synthesized resins was also carried out with respect to the evaluated mechanical properties such as hardness, strength, elastic modulus and fracture toughness. The synthesized CNSL resins yielded many interesting compositions with varied properties increasing the possibilities of various resin formulations which could be used for composites applications in vibrational damping. The electronic packaging applications of nano-composites with high dielectric strength produced with the CNSL matrix are also highlighted.

**Corresponding Author:*

Padmanabhan Krishnan,

Department of Manufacturing Engineering, School of Mechanical Engineering, VIT , Vellore, 632014, India;

Email: padmanabhan.k@vit.ac.in

1. Introduction

India is a world class producer of sugarcane, sugar beet, other tubers like potato and vegetables with starch, cashew and badam, castor oil and soybean, the quantum of bio resins and bio plastics that can be produced from these conventional, organic and genetically modified plants is large. The byproduct of cashew industry, CNSL is unique resource of unsaturated long chain phenolic resin^[1]. India produces about 25 000 tons of cashew and 2500 tons of CNSL per annum. Most of the CNSL oil is consumed internally for furnace oil, paints, pharma, cosmetics, resins and adhesives, and less than about 20 % is exported. The cashew liquid Cardanol is a laminating resin, used in paints, coats, bonding resins and varnishes^[2]. CNSL and cashew friction dust are used in brake linings, pads, faces, discs and shoes. CNSL comes with asbestos or non asbestos containing brake applications. The natural meta substituted alkyl phenol can be produce a series of phenolic resins by catalyzed aldehydes or acids. Many have and characterized the polymerization of cardanol^[3]. Some investigators have synthesized CNSL based phenol-formaldehydes and studied their properties like thermal stability and compared them with standard phenol formaldehydes^[4]. The thermal characterization and physical properties of CNSL were also studied. Tejas S Gandhi et. al. characterized the Mannich base with Cardanol at a low viscosity and concluded that it can used as a polyol for synthesis of rigid polyurethanes^[5]. At VIT, a better variety of CNSL matrix materials for composite applications have been synthesized^[6,7,8]. Novel mechanical properties were obtained and the thermal characterization of different combinations of CNSL were done. This review paper attempts to project the actual possibilities of the bio resin and bio plastic market in India^[9] and provides the knowhow for production of CNSL resins that are known to be termite resistant and hygrothermally more stable than some of the epoxies as cardanol is hydrophobic.

The byproduct of cashew industry, CNSL is a unique resource for unsaturated long chain phenolic distillates, mainly cardanol^[1]. The natural Meta substituted alkyl phenol is polymerized to yield varieties of phenolic resins by catalyzed aldehydes or acids. Due to the phenolic structure of cardanol it can be polymerized and suitably modified for applications^[2]. Menon et al studied and characterized the polymerization of cardanol^[3]. Papadopoulou et al synthesized CNSL phenol-formaldehyde and studied properties and thermal stability comparing with standard phenol formaldehyde^[4]. In industry, resins derived from CNSL are widely employed as friction materials, lami-

nates, adhesives, surface coatings, flame retardants, anti-corrosive paints and medicinal drugs etc.^[1]. One of the main requirements of fiber-reinforced composite materials to be successfully used in practice are their static and dynamic mechanical performance. This review paper focuses on the evaluation of thermal, static, vibrational and electronic properties of naturally derived composite materials with CNSL as the matrix and nano fillers or glass fibres as the reinforcements. Some of the reported findings form first of their kind in the documented literature.

The mechanical properties of glass fabric used in the layup of the composite are, Elasticity modulus = 35 GPa, Shear modulus = 14 GPa, Density = 2.52 g/cm³, Poisson's ratio 0.25. The mechanical properties of CNSL matrix used are, elastic modulus= 1.5 GPa, Density = 0.95 to 1.00 g/cm³ Poisson's ratio= 0.35.

2. Experimental Details

The CNSL made available from Cuddalore (In Tamilnadu which is a cashewnut farming area) is preheated with toluene at 70°C for about an hour and then cured with formaldehyde and alkali at 120°C for two hours or with any of the acids like HNO₃ or H₂SO₄ at 180°C for two hours and then cooled in the oven^[7,8]. The DSC (Differential Scanning Calorimetry) and TGA (Thermal Gravimetric Analysis) analysis were carried out in milligram sized cured samples from room temperature to about 700°C at a heating rate of 10°C/min to obtain information on the thermal stability, glass transition temperature and weight loss versus temperature^[7,8].

The hardness experiments for polymers are normally carried out with Durometers that are of type Shore A for soft plastics and Shore D for hard plastics. The hardness of the material is read off from the display on a scale of 100^[7,8]. Tensile and Single Edge Notch (SEN) test specimens were prepared from the laminate, as per requirements for the tensile test and the Mode I fracture toughness test, respectively^[10-14]. Tests carried out on an electronic Tensometer give the data of load applied and the displacement in the specimen when tested in the opening mode. Tensile specimens are loaded until the failure of the specimen, whereas the SEN specimens are loaded until the pre-crack starts propagating consistently.

Impact modal analysis is one experimental modal analysis technique that is widely used. The vibrational response of the structure to the impact excitation is analysed and measured through the signal analyser and transformed into frequency response function using FFT technique. The measurement of the frequency response function is the heart of modal analysis and the FRFs are used to ex-

tract the frequency modal parameters such as natural frequency and mode shape. The experimental setup is shown in Figure 1.

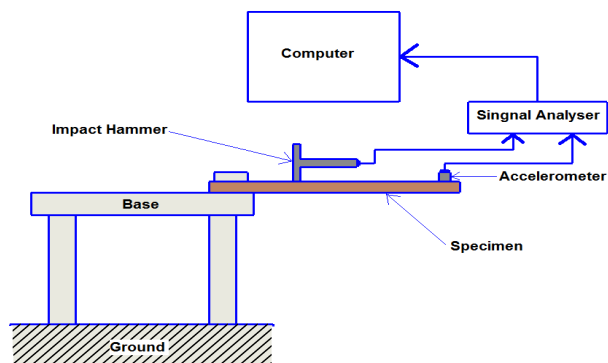

Figure 1. Block diagram of impact hammer modal analysis fixture

The vibrational properties like natural frequencies and damping percentage are extracted from the experimental modal analysis. The prepared composite is first cut into pieces to make specimens for impact hammer modal analysis. The dimensions of the specimens are 250 mm along the length and 25 mm along the width at a 3 mm thickness. To carry out the modal analysis 5 such specimens are prepared [15-18].

The experimental modal analysis of the specimen is carried out in a fixed-free cantilever condition which is fixed to a trestle. A three dimensional accelerometer (KISTLER 8778A500) is glued to the specimen which sends the vibrational response to the connected signal analyser (DEWE 501). Impact hammer (DYTRAN 1051V) is used for the excitation of the specimen in selected locations due to which the specimen vibrates. The vibrational response sent by the accelerometer is amplified by the signal analyser and forwarded to the computer for the post processing. Post processing of the vibrational response is carried out by the software (RT Pro Photon) to plot FFT (force frequency time) and FRF (force response function). The vibrational properties such as first three natural frequencies, damping percentage, etc. of the corresponding modes were extracted [15-18]. The accelerometer is fixed at the edge of the specimen and excitation is given on the top surface of the cantilever specimen. Excitation is given on the specimen by increasing the distance from the accelerometer till the support is reached, to attain vibrational responses for different modes. The results from tests were plotted.

Electronic packaging applications are decided by high dielectric permittivity and thermal conductivity and very low electrical conductivity of the non-hermetic polymeric package composition. $\tan \delta$ and the dielectric permittivity

or constant were measured versus frequency using a N4L impedance analyser.

3. Results and Discussion

The Differential Scanning Calorimetry (DSC) curves present the endothermic and exothermic processes. The DSC endothermic peaks near 250°C correspond to the mass loss observed in Thermal Gravimetric Analysis (TGA) curves. Glass transition causes endothermic shifts in the initial baseline because of the samples' increased heat capacity. Exothermic peaks are observed around 400 to 430 °C temperature for all the six samples which is related to the thermal decomposition and degradation of the resin. Normally DSC peaks are directly related to enthalpy changes in samples. The Parameters studied with the aid of TGA instrument are, a) CNSL decomposition, b) Peak Temperature (T_{max}) for significant degradation and, c) Residual mass at 850 °C. These parameters give information on the thermal stability of CNSL resin. The glass transition temperature for the CNSL resins is around 38°C as evaluated from the DSC plots.

DSC for the samples and the curves of TGA analysis reveal that the CNSL resin decomposition is in three steps. In the first step from 0-300 °C mass loss up to 5 % was observed in the first 4 samples where as in sample 5 and 6 it is maximum i.e. about 10%. This may be due to the moisture removal retained in CNSL. In the second step gradual weight loss occurs in the temperature range 300-450 °C which may be due to degradation of the side chain and small fragments like CH_3 and OH radicals. CNSL is thermally stable up to 450°C. However, in the third and last stage of thermal degradation, a weight loss of around 70% can be observed. This may be due to de-polymerization and degradation of the CNSL matrix. The cured CNSL samples can be safely used up to 250 degree Celsius.

The different combinations of CNSL resin exhibit different physical properties. Samples which are formaldehyde cured, exhibit the highest hardness values in both shore A and D Durometers. The Shore A hardness was about 95 and shore D, about 48. Increasing the percentage of sodium hydroxide catalyst from 5 wt % to 15 wt % causes a decrease in the hardness of the cured CNSL resin down to 85 and 43 in the respective scales. HNO_3 cured samples were foamy, soft and flexible possessing the lowest hardness values in the range of 25 to 30 in shore A scales. Shore D measurements were not possible due to the foamy porous nature of these samples. The H_2SO_4 cured samples exhibited considerable hardness, almost equal to that of the formaldehyde plus alkali cured

samples [7,8]. Depending on the hardness, strength, stiffness or toughness requirements, these resins or sponges may be chosen for composites applications.

The tensile strength of the composite is observed to be lower than that of a glass fabric/ epoxy composite laminate with the same volume fraction of resin. The specimens show moderate interfacial strength between the resin and the fibre. To increase the interfacial strength, different ways of alkali and acid curing could be attempted. The toughness properties are good but slightly lower than that of glass/epoxy or metal modified glass /epoxy composites whose fracture toughness and the strain energy release rate values lie in the region of 20 -40 MPa \sqrt{m} and 2-8 KJ/m², respectively . A higher volume fraction of glass fabric is also expected to ensure higher fracture toughness values [14]. Efforts are on to improve the mechanical properties of CNSL composites through chemistry and fabrication techniques.

Our earlier work gives a detailed discussion of the dynamic testing of glass fabric/ CNSL matrix composites using an impulse hammer technique. Vibrational properties like natural frequencies, Q factors and damping percentages of the glass fabric/ CNSL matrix composite were recorded and analyzed for the first time and reported. The CNSL resin is found to be a good damping material. The composite's dynamic characteristics were compared with those of glass/ epoxy and carbon/epoxy specimens. From the vibration response plots the vibration properties are given below. The 1st natural frequency for the CNSL Glass fabric/ epoxy composite was around 10 Hz, the corresponding Q factor was very low at about 1.6 and damping at about 28 %. The facts establish a better damping than glass /epoxy specimens. Thus, the CNSL composites exhibit a higher damping under vibrations than other synthetic epoxy based composites [15-18]. The CNSL resin can also be used as an effective electronic IC or system packaging material. The existing epoxy-phenolic composites are costlier, toxic and derived from synthetic resources. Hence, they are environmentally toxic and difficult to dispose. A novel nano-composite was derived from an environment friendly cashew nut shell liquid by curing it with thermally conducting and electrically insulating fillers and formaldehyde. It is also relatively cheaper. Heat generated during operation was dissipated off effectively. The application's functional areas include good thermal conductivity at a low electrical conductivity like Use in electronic packaging materials, encapsulants and sealants for electronic devices and components that require high heat dissipation of the heat generated and a low electrical conductivity with a high dielectric breakdown strength . The nano-composite was made from bio resources making

it eco-friendly. Figure 2 shows a CNSL nano-composite disc cured for dielectric measurements [19].



Figure 2. CNSL Resin matrix disc cured for Dielectric permittivity measurements

One of the foremost applications of these bio plastic and bio resin composites in their recyclability and ease of disposal through conversion of the bio-plastics in to useable fuel by de-polymerization with the aid of a catalyst and condensing the pyrolysed gas in to fuel oil .



Figure 3. Waste bio-plastics to fuel production through de-polymerization

Bio-plastic waste can be pyrolysed and bio plastic petrol, diesel kerosene and wax can be derived from de-polymerisation through a catalyst chamber using Ammonium Sulphate as the catalyst. The condensed vapours can be collected based on their boiling points as shown in Figure 3 which describes the apparatus that was designed and developed by us to achieve these goals successfully [20].

The cashew nut shell liquid based extracts have also been successfully synthesized into medicinal drugs for treating fever, inflammation and analgesic symptoms as the phenolic Cardol derivatives from the CNSL liquid are known to possess pharmaceutical qualities. Their potential in treating and curing corona virus related infection can be explored.

4. Conclusions

In this investigation, we found that the CNSL resin can be cured with formaldehyde and acid curing. From the results of DSC and TGA, it is observed that the CNSL resins show good thermal stability up to 450°C. The glass transition temperature for the CNSL resins is around 38°C. The alkali catalyzed resins were found to be harder than the acid catalyzed resins. Thus, the thermal and physical properties were studied and reported. The tensile properties, fracture toughness in mode I and its strain energy release rate were evaluated for a CNSL/ glass fabric composite and reported. They were found to be comparable but lower than glass/ epoxy composites. The vibration properties such as natural frequencies, Q factors and damping percentages of a CNSL based glass fabric composite show only up to 3 modes. The CNSL composite is a high damping material wherein the natural frequencies are low and the Q factor is lower than that of glass/epoxy for the same volume fractions. The damping percentage is also higher. The electronic applications of these bio synthesized materials and their nano-composites in packaging is proven due to the possibilities of high thermal conductivities, low electrical conductivity, very high dielectric constants and low costs. A method for safe disposal of these plastics and their composites after use with significant returns in the production of useable fuel through reverse polymerization and recyclability has been demonstrated with success.

Acknowledgments

The author wishes to acknowledge all his co-authors and editors for the excellent cooperation. Thanks are due to the VIT management for the support. Bi-Lingual publishers are gratefully acknowledged for bringing out this review article.

References

- [1] Gedam PH, Sampathkumaran PS, Cashew nut shell liquid: Extraction, Chemistry and Applications, Progress in Organic Coatings [J]. 1986, 14: 115.
- [2] Lubi, M. C. & Thachill, E. B. - Des. Monomers Polym.[J]. 2000, 3: 123.
- [3] Menon ARR, Sudha JD, Pillai CKS, Mathew AG, J. Sci. Ind. Res.[J]. 1985, 44: 324.
- [4] Papadopoulou E, Chrysalis K, Thermochemica Acta. [J]. 2011, 512: 105.
- [5] Gandhi TS, Patel MR, Dholakiya BZ, Res Chem Intermed[J]. DOI: 10.1007/s11164-013-1034-2, 2014
- [6] Sai Naga Sri Harsha, Padmanabhan.K.. ICNP International Conference, Kottayam,Kerala, India, 2015.
- [7] Sawant AV, Takalkar AR, Padmanabhan.K. ICNP International Conference, Kottayam, Kerala, India, 2015.
- [8] Sawant AV, Takalkar AR, Padmanabhan K.. Synthesis and characterization of cashew nut shell liquid matrix compositions for composites applications. Bio polymers and bio materials, Edited by Sabu Thomas et.al., 2018, 69-77.
- [9] Padmanabhan. K, Bio resins, Bio plastics synthesized from Agricultural products-The Indian Perspective. Biopolymers and Biomaterials, Edited by Sabu Thomas et. al. CRC press, AAP press, 2018, 197-204
- [10] ASTM 3039, Tensile properties of reinforced plastics, West Conshohocken, PA, 2010.
- [11] Prakash V, Aditya R, Kurup AL, Padmanabhan K, International Journal of Contemporary Engineering Science and Technology, 2010, 1: 55.
- [12] Kumar V, Balachandran V, Sushen V, Padmanabhan K, International Journal of Contemporary engineering science and technology[J]. 2010, 1: 77.
- [13] Kumaran D, Narayanan R, Reddy A, Padmanabhan K, Intl. Journal of manufacturing science and engineering[J] 2010, 2: 97.
- [14] Sai Naga Sri Harsha, Padmanabhan K, Fabrication and fracture toughness properties of cashew nut shell liquid resin based Glass Fabric composites, Polymeric and Nanostructured Materials, Edited by Sabu Thomas et. al. CRC press, AAP press, 2018:135.
- [15] Sai Naga Sri Harsha, Padmanabhan. K, Murugan R, ICNP International Conference, Kottayam,Kerala, India, 2015.
- [16] Murugan R, Ramesh R, Padmanabhan K, Procedia Engg[J]. 2014, 97: 459.
- [17] Murugan R, Ramesh R, Padmanabhan K, Jeyaram R, Krishna S, Applied Mechanics and Materials[J]. 2014, 529: 96.
- [18] Sai Naga Sri Harsha, Padmanabhan.K, Murugan R. Vibrational properties of a glass fabric / Cashew nut shell liquid resin composite, A book chapter in the book Polymeric and nanostructures materials' edited by Sabu Thomas et. al. CRC Press, Apple Academic Press, 2018: 49.
- [19] Padmanabhan K, Joshi GM, Suriya Prabha R, Rajendran V. Synthesis and Characterization of Acid Cured Cashew Nut Shell Liquid Based Nano Composites for Electronic Packaging Applications, Conference: NANO-15, At Tiruchengode, Tamil Nadu, Tiruchengode, Tamil Nadu, KSRCT, 2015.
- [20] Padmanabhan K, Deepak Kumar T, Ganesh P, Haricharan AV, Karthik RS, Devasagayam G, Journal of energy storage and conversion[J]. 2012, 3: 225.