

ARTICLE

# Artificial Intelligence Technique and Wireless Sensor Networks in Energy Management System for Secure Power Optimization

Ayuba John<sup>1\*</sup> Abdulazeez Yusuf<sup>2</sup> Abdulhamid Ardo<sup>3</sup>

1.Department of Cyber Security, Faculty of Computing, Federal University Dutse Jigawa State, Nigeria

2.Department of Computer Science, Faculty of Computing, Federal University Dutse Jigawa State, Nigeria

3.Department of Information Technology, Faculty of Computing, Federal University Dutse Jigawa State, Nigeria

---

ARTICLE INFO

*Article history*

Received: 07 April 2021

Accepted: 18 May 2021

Published Online: 21 May 2021

---

*Keywords:*

Wireless sensor network

Artificial intelligent

Energy management system

Expert system

Smart grids

---

ABSTRACT

The modern basic building blocks of a control system consist of data acquisition, dispensation of data by the system operators and the remote control of system devices. However, the physical controls, technical examinations and deductions were originally implemented to aid the process and control of power system design. The complexity of the power system keeps increasing due the technical improvements, diversity and dynamic requirements. Artificial intelligence is the science of automating intelligent activities presently attainable by individuals. Intelligent system techniques may be of excessive benefit in the application of area power system controls. Whereas smart grid can be measured as a modern electric power grid structure for better productivity and dependability via automatic control, excessive power converters, modern communications setup, sensing and metering equipment, and modern energy management techniques established on the optimization of demand, energy and network accessibility, and so on. The enormous depiction of the entire transmission grid, in the perspective of smart grids, is quite unclear; and in Nigeria no studies have been put on ground in order for the existing network to be turn into a smart grid. In this research work emphasis is placed on generation and transmission stations; power optimization using artificial intelligent techniques and wireless sensor networks for power control management system.

## 1. Introduction

Artificial intelligence (AI) is the application of scientific knowledge in building intelligent device specifically intelligent computer programs<sup>[27]</sup>. Though, you might assume the mobile sensing will act as a progressively vital role in the monitoring of power system.<sup>[18]</sup> Generally artificial intelligence is recognized to be the intelligence demonstrated by expertise and software, for instance, ro-

bots and computer programs. Colloquially, the word “artificial intelligence” is useful once a device mimics “reasoning” roles that individuals are associated with other human thoughts, especially “learning” and “problem solving”<sup>[20]</sup>. The word is commonly used to the task of establishing systems furnished with the knowledgeable features and human behaviors, especially the capacity to think, reason, find the meaning, simplify, differentiate, learn from previous knowledge or correct their errors. A Wireless Sensor

---

*\*Corresponding Author:*

*Ayuba John,*

*Department of Cyber Security, Faculty of Computing, Federal University Dutse Jigawa State, Nigeria;*

*Email: ayuba.john@fud.edu.ng*

Network (WSN) is an arrangement encompassed of sensing or a computing wireless-based communication component that is categorised by a task oriented sensor node which provides an administrator with the ability to develop, sense, and react to events in a known locality. There is excessive need of artificial intelligent and wireless sensor networks in power station to improve the computational period and accurateness owing to broad and massive system data control, Composite, flexible and great volume of data which is used in control, analysis and learning, and as well as in carrying out system maintenance.

## 2. Review of the Related Work

In the research work by [21], he carried out clear studies on the background of the equipment's used in power system for fault monitoring and data acquisition control in Nigerian Electric Power System; National Electric Power Authority (NEPA), and also the demand for good instrumentation to counter fault in power system monitoring has been underlined. A research carried out on NEPA generation adequacy by [3,11]; highlighted that the current generation capacity of NEPA is sufficient for its load, yet in Nigeria, blackout occurrence is a consistent event. The blackout occurrence is consequently an operational problem. This typically effects from voltage collapse initiated by overcapacity of some injection substations and rarely short circuit faults on the transmission and distribution lines. The research by [22], looks into how power system of Nigeria has contributed to the growth of the nation and It proceeds an acute survey of the previous and current situation of the sector; which was also look into what were the challenges of the sector, and conceivable way out. [26], provide the general depiction of supervisory control and data acquisition (SCADA) system for monitoring and controlling of the whole electricity network of which offers uninterrupted electricity supply to the consumer. It saves record of the system operation which is useful for receiving a perfect portrait of the whole status of the system. Since the status of the whole system network can be understood within a few seconds, the daily load demand can decide according to the requirement. The application of SCADA has simplified the managing of the electricity network with minimum human interference [1,31].

This research by [4], describes monitoring system and networking in SCADA based electrical distribution technology for primary substation and according to the simulation results, the user can easily control based on this graphic user interface (GUI) software environment. [39], the main purpose of power system management energy management system (EMS) or SCADA system is to generate, transmit and distribute electric energy efficiently. SCADA

main function is to supervise, control and manage power networks in an integrated manner. [28,30], provides the model of artificial intelligence, areas of artificial intelligence and the artificial intelligence techniques used in the field of power systems. [13,16]; gave the cleared picture of the present prospects in technological development and design challenges of wireless sensor networks for smart grid applications that may enhance a proper management of power system. [2,12], they explained a wireless sensor networks technology that is used in a smart grid and the communication protocols that need to be considered as a general yardstick. Prominently, node lifetime and link dependability on wireless sensor networks for smart grid applications have been estimated. [8,34]; gives the examination of several wireless communication standards, cyber security issues and solutions for WSN are discussed also.

In the research of [8,35], they used wireless sensor networks and power line communications (PLCs) to implement a smart home control system network. The goals were to regulate the consequence of wireless interfering on a smart home control network and excessive energy consumption of a smart home. [15], a remote WSN with one controller, which is incorporated into the PLC transceiver, is established in each room. The controller is accountable for relocating conservational parameters acquired by WSNs to the management station via PLCs [23]. The control messages for home appliances are directly transferred using PLCs rather than WSNs [32].

The collection of previous research has sited excessive emphasis on the dissemination system and demand side as shown by the extensive sort of developing technologies applied to them. The clear picture of the entire transmission grid, in the perspective of smart grids, is quite vague; and in Nigeria no studies have been put on ground in order for the existing network to be turn into a smart grid. In this research work emphasis is placed on generation and transmission stations; power optimization using artificial intelligent techniques and wireless sensor networks for power control management system.

## 3. Energy Management Systems

The critical study of the energy management system shows that it consists of five levels. [28,34] The electrical power network level is the primary source of generation stations which generate the power collected by remote terminal units (RTU) and forwarded to their master remote terminal unit (MRTU) and send to the Supervisory control and data acquisition (SCADA) system where the system operators manage it through the main machine interface and to the distribution stations for sell to the end users.

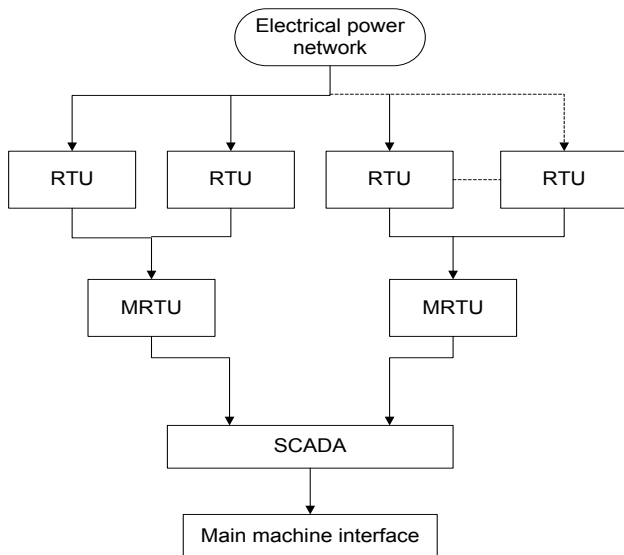

**Figure 1.** Energy Management systems.

The major problems of the energy management systems are as follows:

- *The inability of the SCADA network to report data in real time from the generation station to the transmission station.* The current monitoring system in a control center rest on the state estimators, which are based on data collected via SCADA systems and remote terminal units (RTUs). The data from the generation stations are collected from the MRTU- master remote terminal units and transfer it via a tablet to the control center and from the transmission substations to the transmission control center.

- *Market/client needs.* The standard system process technologies and power market strategies essential to the development and sustenance of the transparency and right of the economical market. Client gratification with electricity consumption ought to be upgraded as long as high quality/price ratio electricity and clients' autonomy is to relate through the grid.

- *Infrastructure challenges.* The current set-up for electricity transmission has rapidly aging mechanisms and inadequate funds for enhancements. Through the gravity of the growing load demands, the network jamming is becoming worse. The fast accessible examination tools, wide-area monitoring, capacity and regulator, fast and perfect defenses are required to increase the dependability of the networks.

- *Innovative technologies.* Considering the innovative technologies, comprising of novel tools, advanced power electronics, and communication technologies, are not yet established or commercially obtainable for the revolution of transmission grids; thus, the current grids lack sufficient compatibility to lodge the application of spear-point

technologies in the practical networks.

## 4. Proposed Systems Model

### 4.1 Artificial Intelligence Technique Expert System Techniques

Artificial intelligence techniques promote the speed of performance of the composite program, an expert system is a computer system that imitates the decision-making capability of a human expert. [5,18] categorically emphasized that an expert systems are established to resolve composite problems by reasoning around knowledge, signified mainly as if-then rules rather than over conservative technical code. According to [27], the expert systems that were developed earlier were designed to solve some of the problems that were common to human knowledge until later on more functionalities were introduced to enhance it problem solving ability. [9,17,37] states that among the artificial intelligent software that was developed as a computer programs to help in problem solving; Expert systems were not exceptionally categorized under it but as originally part of it and subdivided into two sub-systems: the inference engine and the knowledge based. [28], the knowledge based signifies facts and rules. [4,33] the inference engine applies the rules to the known facts to realize new facts. Inference engines can likewise comprise description and debugging abilities. [36,38] these systems are used in real world applications in which the essential for classification of patterns and pattern recognition ascends. They are categorized through their architecture: number of layers and topology, connectivity patterns, feed forward or recurring [6,10,19].

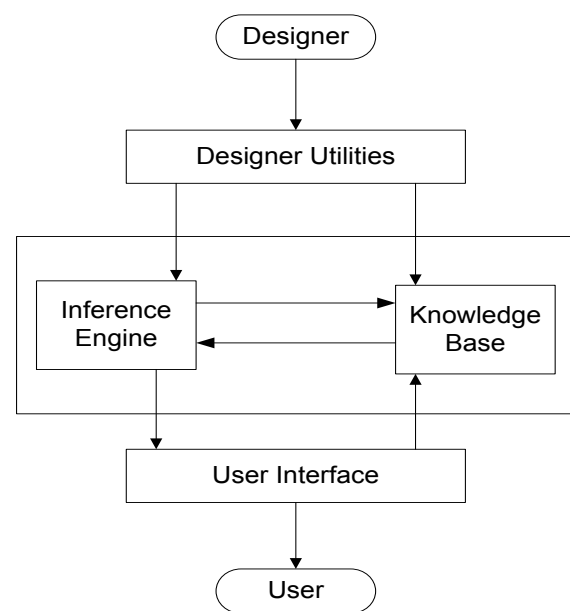

**Figure 2.** the Architecture of an Expert System flowchart

Subsequently expert systems are essentially computer programs, the procedure of inscription programs is simpler than essentially calculating and approximating the value of parameters used in generation, transmission and distribution. Slight changes even after system design can be simply set since they are computer programs. Essentially, assessment of these values can be done and additional research for increasing the effectiveness of the development can be similarly implemented. The expert system manages the SCADA machine interface by automatically distributing the power generated to the end users, it takes care of alarm handling, contingency analysis, and remedial measures fault analysis during system failure.

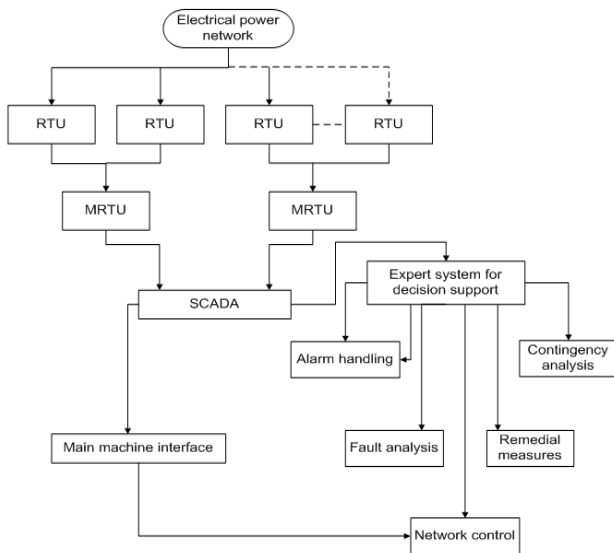

Figure 3. the proposed expert energy management systems

#### 4.2 Wireless Sensor Networks Base Smart Grid

Looking at the current applications in the modern wireless sensor network used in smart grid, they can be basically grouped into three: we have the consumer side that serve as the end users of electricity; mostly use for domestic and commercial purposes, follow by the transmission and distributing side; where the system operators or the transmission engineers are properly managing the load tired up to the grid and share it to the distribution stations in order to sell it for domestic and commercial users, the third side is the generation stations; where the power source are and loads were being generated before it is tired to the grid [13,14].

##### (i) The Consumer or the end user's side of the smart grid

At this part of the smart grid, all the customers are having a kind of indirect relationships with the smart grid

through an enhanced modern metering infrastructure used for domestic and commercial energy management; which are used for automatic process control and electricity power monitoring on the equipment's in used by the consumers.

##### (ii) The transmission and distribution side of the smart grid

The wireless sensor networks smart grid here comprises the power line transmission stations with substations all having their major functions on the grid. They are accountable for the transmission and distributions of the load tied to the national grid. The wireless sensor network smart grid in this context consists of the overhead transmission line monitoring, fault and outage detection evaluation, and the short-circuiting of the subversive cabling monitoring system.

##### (iii) The generation side of the smart grid

It consists of the power generation stations which generates the loads and are remotely monitoring it in a real time on the smart grid by the system operators. The amount of power generated per day is tied to the national grid for proper channeling to the consumers.

The role that wireless sensor network can play in a smart grid cannot be over emphasized; considering the flexibility of the communication requirement in the technologies development for energy distribution infrastructures [25,29,32]. The wireless sensor network routinely collects the power from the generation stations and transmitted it to the end users while the expert system handles the alarm, fault exploration, contingency analysis and remedial measures during system failure.

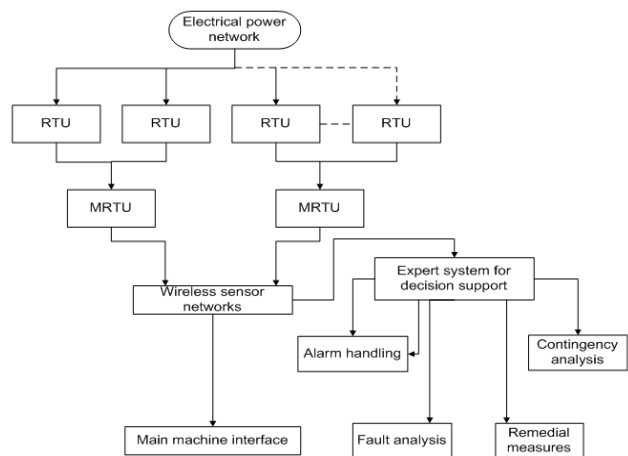

Figure 4. the proposed Wireless sensor networks control of energy management system

## 4. Conclusions

In this paper a critical studies of power management

system in Nigeria has been carried out and the problems with the current system has been analyzed to procure a proposed power optimization systems using artificial intelligence technique and wireless sensor networks to handle the entire transmission grid in the perspective of smart grids. Two different models were proposed in this research work which will be simulated and the results will be compared based on the efficiency of each model in the next subsequent paper.

## Recommendation

The studies show that the transmission line cables need to be replaced with a modern high capacity transmission cables and the dualism of the transmission line can help in avoiding power tripling in adopting the proposed systems.

## References

- [1] Akinwumi, A. O. K. S. A. (2016), Migrating from Closed to Open Supervisory and Data Acquisition (SCADA) System: A Case Study of Transmission Company of Nigeria (TCN).
- [2] Amis, A. D., & Prakash, R. (2000). Load-balancing clusters in wireless ad hoc networks. Paper presented at the Application-Specific Systems and Software Engineering Technology, 2000. Proceedings. 3rd IEEE Symposium on.
- [3] Anwah, N., & Okonkwo, R. (1990). An Appraisal of NEPA's Generation Adequacy to Year 2000. Nigerian Journal of Technology, 14(1), 35-42.
- [4] Ares, B. Z., Park, P. G., Fischione, C., Speranzon, A., & Johansson, K. H. (2007). On power control for wireless sensor networks: System model, middleware component and experimental evaluation. Paper presented at the Control Conference (ECC), 2007 European.
- [5] Banerjee, R. (2015). Artificial Intelligence in Power Station. Artificial Intelligence, 3(7).
- [6] Bonivento, A., Fischione, C., Necchi, L., Pianegiani, F., & Sangiovanni-Vincentelli, A. (2007). System level design for clustered wireless sensor networks. IEEE Transactions on Industrial Informatics, 3(3), 202-214.
- [7] Chandia, R., Gonzalez, J., Kilpatrick, T., Papa, M., & Sheno, S. (2007). Security strategies for SCADA networks Critical Infrastructure Protection (pp. 117-131): Springer.
- [8] Chhaya, L., Sharma, P., Bhagwatikar, G., & Kumar, A. (2017). Wireless Sensor Network Based Smart Grid Communications: Cyber Attacks, Intrusion Detection System and Topology Control. Electronics, 6(1), 5.
- [9] Chobot, E., Newby, D., Chandler, R., Abu-Mulaweh, N., Chen, C., & Pomalaza-Ráez, C. (2013). Design and implementation of a wireless sensor and actuator network for energy measurement and control at home. arXiv preprint arXiv:1305.1259.
- [10] De Oliveira, M. V., & de Almeida, J. C. S. (2013). Modeling and control of a nuclear power plant using AI techniques. International Nuclear Atlantic Conference.
- [11] Dener, M., & Bostancıoğlu, C. (2015). Smart technologies with wireless sensor networks. Procedia-Social and Behavioral Sciences, 195, 1915-1921.
- [12] Fu, Y., Sha, M., Hackmann, G., & Lu, C. (2012). Practical control of transmission power for wireless sensor networks. Paper presented at the Network Protocols (ICNP), 2012 20th IEEE International Conference on.
- [13] Gungor. V. C, Lu. B, Hancke. G. P, "Opportunities and Challenges of Wireless Sensor Networks in Smart Grid," IEEE on Trans. Ind. Electron., vol. 57, no. 10, pp. 3557-3564, October 2010.
- [14] Gungor. V. C, Lambert. F. C, "A Survey on Communication Networks for Electric System Automation," Computer Networks, vol. 50, pp. 877-897, May 2006.
- [15] Happonen, A. (2005). Low Power Design for Wireless Sensor Networks: Jan.
- [16] Kolenc, M., & Zajc, M. (2011). Wireless sensor networks and data analysis in Smart Grids. Paper presented at the 7th IEEE International Symposium on Information and Communication Technologies—INTSIKT.
- [17] Lazaropoulos, A. G. (2014). Wireless sensor network design for transmission line monitoring, metering, and controlling: introducing broadband over power lines-enhanced network model (BPLeNM). ISRN Power Engineering, 2014.
- [18] Leondes, Cornelius T. (2002). Expert systems: the technology of knowledge management and decision making for the 21st century. pp. 1-22. ISBN 978-0-12-443880-4.
- [19] Li, F., Qiao, W., Sun, H., Wan, H., Wang, J., Xia, Y., Zhang, P. (2010). Smart transmission grid: Vision and framework. IEEE transactions on Smart Grid, 1(2), 168-177.
- [20] Nath, R. P., & Balaji, V. N. (2014). Artificial intelligence in power systems. IOSR Journal of Computer Engineering (IOSR-JCE), e-ISSN, 2278-0661.
- [21] Okonkwo, R. (1996). Instrumentation for Power System Disturbance Monitoring, Data Acquisition and Control in Nigeria. Nigerian Journal of Technology, 17(1), 30-34.

- [22] Oladipo, F., & Olowu, T. (2014). The Nigerian power system till date: a review. *International Journal of Advance Foundation and Research in Science & Engineering*, 1, 14.
- [23] Othman, M. F., & Shazali, K. (2012). Wireless sensor network applications: A study in environment monitoring system. *Procedia Engineering*, 41, 1204-1210.
- [24] Park, P. G., Fischione, C., & Johansson, K. H. (2008). Experimental evaluation of power control algorithms for wireless sensor networks. *IFAC Proceedings Volumes*, 41(2), 619-624.
- [25] Park, S., Choi, M.-i., & Kang, B. (2013). Design and implementation of smart energy management system for reducing power consumption using ZigBee wireless communication module. *Procedia Computer Science*, 19, 662-668.
- [26] Roy, R. B. Application of SCADA for Controlling Electrical Power System Network.
- [27] Russell, Stuart; Norvig, Peter (1995). *Artificial Intelligence: A Modern Approach* (PDF). Simon & "World Nuclear Power Reactors 2007-08 and Uranium Requirements".
- [28] Satish Kumar & Ravali Cherukuri, (2017), A Survey on Artificial Intelligence Techniques in Power Station, *International Journal of Innovative Research in Science, Engineering and Technology*, Vol. 6, Issue 1.
- [29] Siano, P., Cecati, C., Citro, C., Siano, P., "Smart Operation of Wind Turbines and Diesel Generators According to Economic Criteria," *IEEE Trans. on Industrial Electronics*, vol. 58, no. 10, pp (in press) Digital Object Identifier: 10.1109/TIE.2011.2106100.
- [30] Suh, C., Ko, Y.-B., Lee, C.-H., & Kim, H.-J. (2006). The Design and Implementation of Smart Sensor-based Home Networks. Paper presented at the Proceedings of the International Symposium on Ubiquitous Computing Systems, (UCS'06), Seoul, Korea.
- [31] Terezinho, F. (2015). SCADA Systems Automate Electrical Distribution. *Indussoftware*.
- [32] Tuna, G., Gungor, V. C., & Gulez, K. (2013). Wireless sensor networks for smart grid applications: a case study on link reliability and node lifetime evaluations in power distribution systems. *International Journal of Distributed Sensor Networks*, 9(2), 796248.
- [33] U.S Department of Energy, 2011, Available: <http://www.oe.energy.gov>.
- [34] Uhrig, R. E., Hines, J. W., & Nelson, W. R. (1998). Integration of artificial intelligence systems for nuclear power plant surveillance and diagnostics. *Short Course Notes*.
- [35] Win, K. T. Z., & Tun, H. M. (2014). Design and implementation of SCADA system based power distribution for primary substation (control system). *Int. J. Electron. Comput. Sci. Eng*, 3, 254-261.
- [36] Wollenberg, B. F., & Sakaguchi, T. (1987). Artificial intelligence in power system operations. *Proceedings of the IEEE*, 75(12), 1678-1685.
- [37] World Nuclear Association; *The economics of nuclear Power*, updated July 2012.
- [38] Xu, M., Ma, L., Xia, F., Yuan, T., Qian, J., & Shao, M. (2010). Design and implementation of a wireless sensor network for smart homes. Paper presented at the Ubiquitous Intelligence & Computing and 7th International Conference on Autonomic & Trusted Computing (UIC/ATC), 2010 7th International Conference on.
- [39] Zaw, A. M., & Tun, H. M. (2014). Design and Implementation of SCADA System Based Power Distribution for Primary Substation (Monitoring System). *Int. J. Science, Eng. Technol. Res*, 3(5), 1542-1546.